



FPK02

Max Flow: 25 gpm (95 lpm)



FPK02 In-Line Cartridge Filters

Working Pressures to:

6090 psi / 42,021 kPa / 420 bar

Rated Static Burst to:

9135 psi / 63,000 kPa / 630 bar

Flow Range To:

25 gpm / 95 lpm

Applications

- High Pressure Circuits
- In-Plant Systems
- Meets HF2 Specification
- Mobile Equipment
- Power Steering Circuits
- Servo Valve Circuits



Features

The FPK02 is built to withstand pressures of over 6000 psi (420 bar). It features a cast iron head and cold-extruded steel housing for ultimate strength and durability. This filter meets the HF2 in-plant automotive specification. Bypass options include 87 psi/6 bar bypass, bypass with reverse-flow check valve, or no bypass.

Take advantage of our mix and match system of in-stock heads, housings and cartridges, so you can get exactly what you need. You can also choose the media type and configuration that's best for your application. All FPK02 filters contain Synteq™, Donaldson's exclusive synthetic fiber media formulated especially for hydraulic filtration.

Beta Rating

- Performance to $\beta_{<40}_(c)=1000$

Porting Size Options

- SAE-12 O-Ring

Replacement Filter Lengths

- 4.41" / 111.9mm
- 4.46" / 113.2mm
- 8.16" / 207.2mm
- 8.28" / 210.3mm

Standard Bypass Ratings

- 87 psi / 600 kPa / 6 bar
- 87 psi Bypass with reverse-flow check valve
- No Bypass

Assembly Weight

- 4.41" Assembly: 9.2 lbs / 4.2 kg
- 8.28" Assembly: 13.2 lbs / 6.0 kg

Operating Temperatures

- -20°F to 250°F / -29°C to 120°C

Filter Collapse Ratings

- 290 psi / 2000 kPa / 20 bar (standard)
- 3000 psi / 20,700 kPa / 207 bar (high collapse)



FPK02 Specification Illustrations

ASSEMBLY - SIDE VIEW

All dimensions are shown in inches [millimeters].

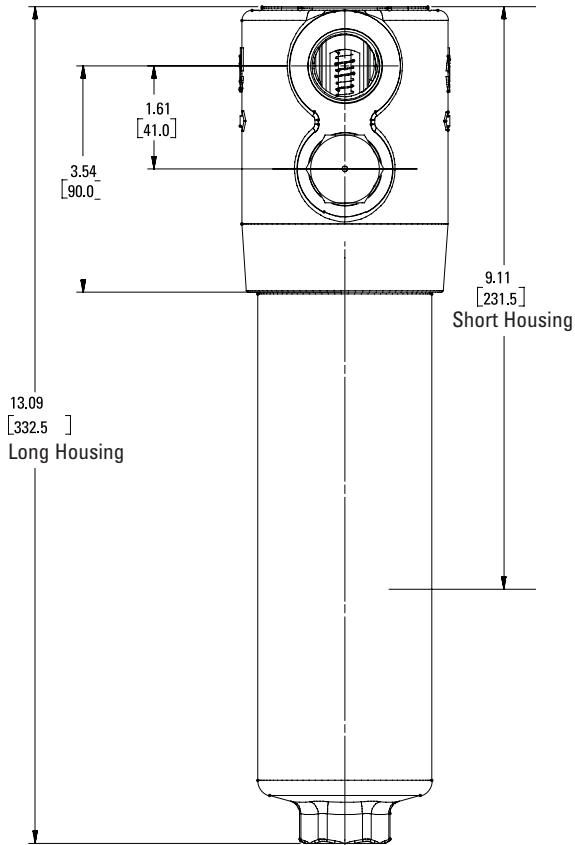

HEAD - TOP VIEW

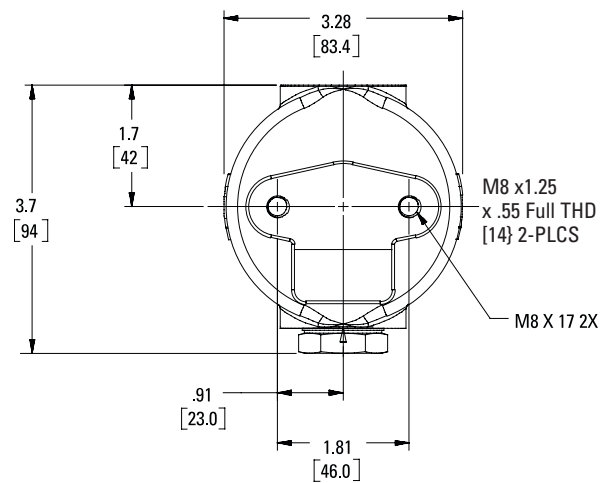

HEAD - SIDE VIEW

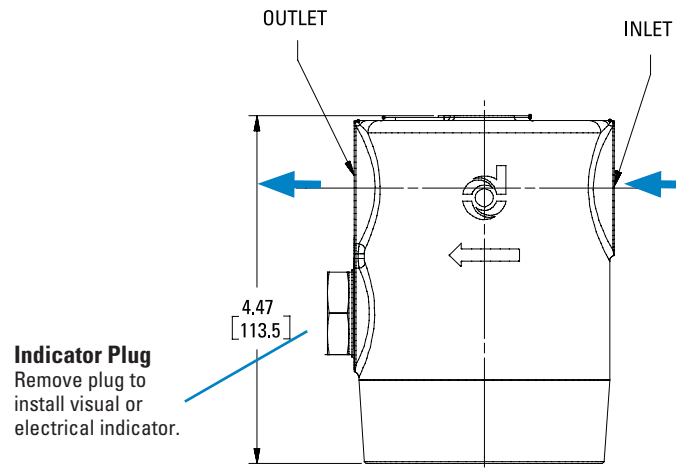

Indicator Plug
Remove plug to install visual or electrical indicator.



FPK02

Max Flow: 25 gpm (95 lpm)



FPK02 Components

Filter Choices

Media Type	$\beta_{x(c)} = 1000$	Length		Part No.	Comments
	Rating based on ISO 16889	in	mm		
DT Synthetic	<4 μm	4.39	112	P566194	DT-9020-4-2UM
	5 μm	4.39	112	P566195	DT-9020-4-5UM
	5 μm	4.46	113	P167180	DT-9021-4-5UM, High Collapse
	8 μm	4.39	112	P566196	DT-9020-4-8UM
	12 μm	4.39	112	P566197	DT-9020-4-14UM
	12 μm	4.46	113	P167181	DT-9021-4-14UM, High Collapse
	23 μm	4.39	112	P566198	DT-9020-4-25UM
	<4 μm	8.18	208	P566199	DT-9020-8-2UM
	5 μm	8.18	208	P566200	DT-9020-8-5UM
	5 μm	8.18	208	P167182	DT-9021-8-5UM, High Collapse
	8 μm	8.18	208	P566201	DT-9020-8-8UM
	12 μm	8.18	208	P566202	DT-9020-8-14UM
	12 μm	8.18	208	P167183	DT-9021-8-14UM, High Collapse
	23 μm	8.18	208	P566203	DT-9020-8-25UM

Filter Notes: All Donaldson DT filters utilize glass fiber media with an epoxy-based resin system for the ultimate in chemical compatibility. All Donaldson DT filters are potted with epoxy-based adhesives. Standard collapse DT designs are double wire-backed using epoxy-coated steel mesh for maximum pleat support and dirt capacity. Fluorocarbon seals are standard on all Donaldson DT filters. Refer to the table in the Technical Reference Guide for fluid compatibility with our filter media. If you're filtering diester, phosphate ester fluids, water glycol, water/oil emulsions, and HWCF over 150°F/83°C, use filters with seals made of fluorocarbon. Donaldson "high collapse" filters, with their steel end caps and wire-backed media, are rated to withstand up to 3000 psi/20,700 kPa before collapsing. High collapse designs are double wire-backed using stainless steel mesh and are potted into machined aluminum endcaps for greater filter integrity in critical applications. The fluorocarbon seal/high collapse filters also use epoxy potting and media seam seals for added chemical compatibility.

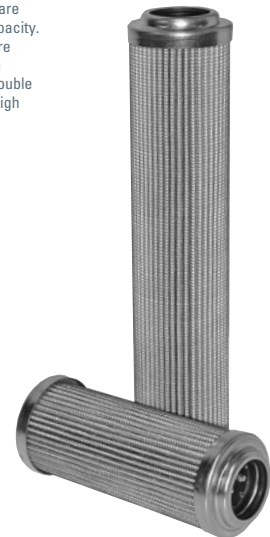

Housing Choices

Length (in)	Part No.
4.4" filter	P762769
8.2" filter	P762770

Head Choices

Port Size	Bypass Rating	Part No.
SAE-12 O-Ring	87 psi / 6 bar	P762766
SAE-12 O-Ring with reverse-flow check valve	87 psi / 6 bar	P762767
SAE-12 O-Ring	No Bypass	P762768

NOTE: Indicator port is machined and plugged. Replace plug with indicator of choice: P171945 (visual) or P761056 (electrical).

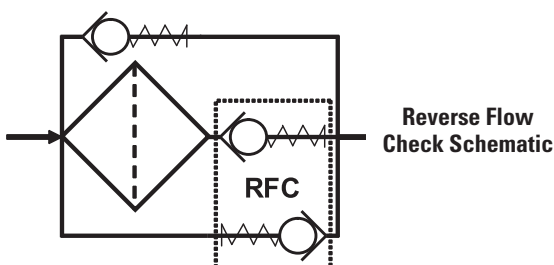

Performance Data

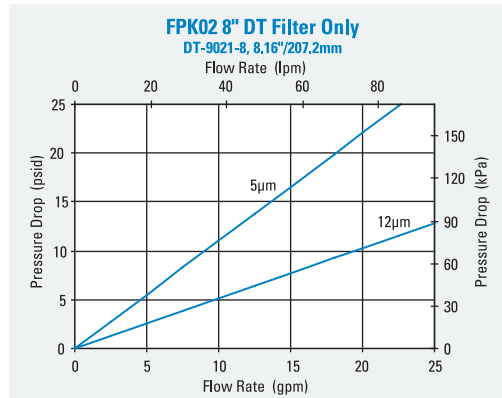
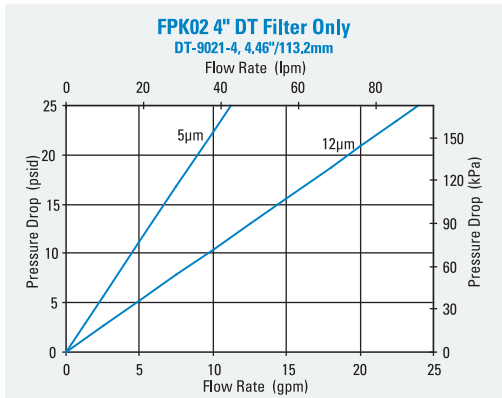
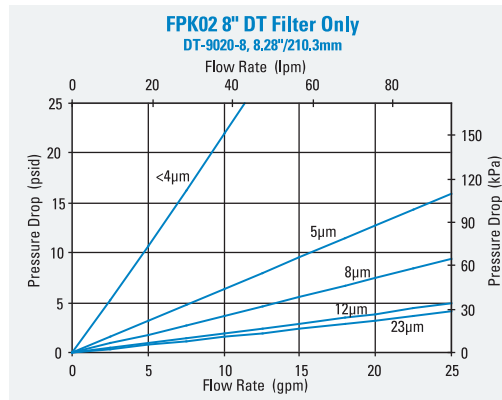
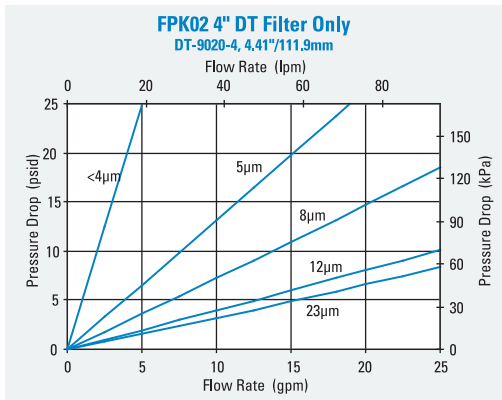
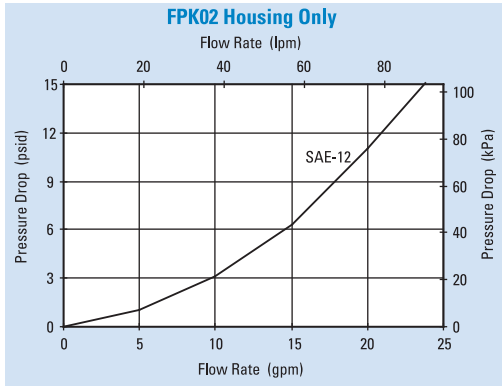



FPK02

Max Flow: 25 gpm (95 lpm)

FPK02 Service Parts

SERVICE PARTS NOTE:

Some service parts may not be stocked. Please contact your Donaldson sales representative for lead time details.

When installing the FPK02 housing onto an installed head, torque it to 15 ft-lbs./2.1 kg-m.

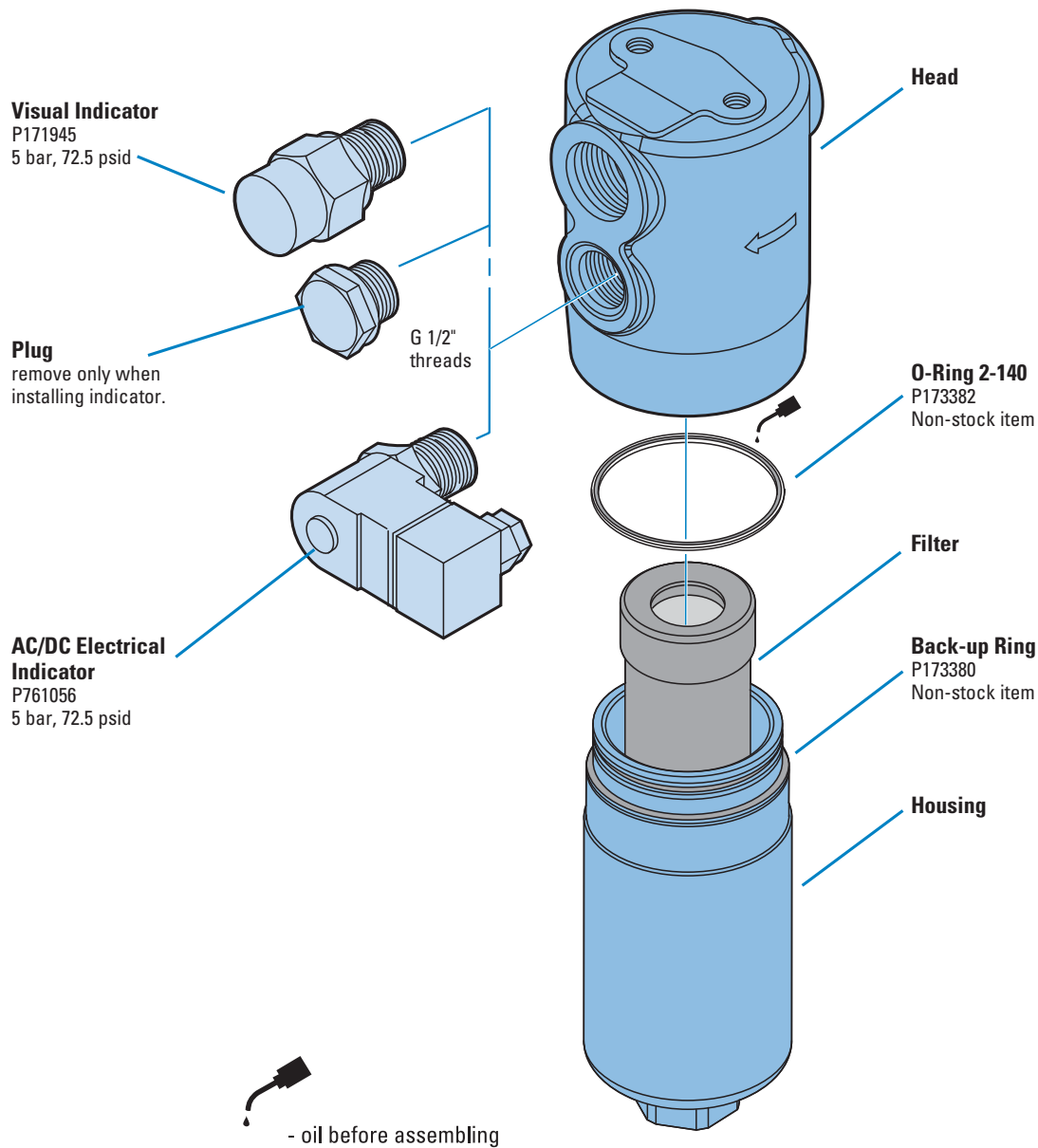

FPK02 Service Parts

When installing the FPK02 housing onto an installed head, torque it to 15 ft-lbs./2.1 kg-m.

SERVICE PARTS NOTE:

Some service parts may not be stocked. Please contact your Donaldson sales representative for lead time details.

