



Downflo® Workstation

DWST 4-1, 4-2, 4-3, 4-4 and DWST 6-1, 6-2, 6-3 and 6-4

Installation and Operation Manual

Installation, Operation, and Service Information

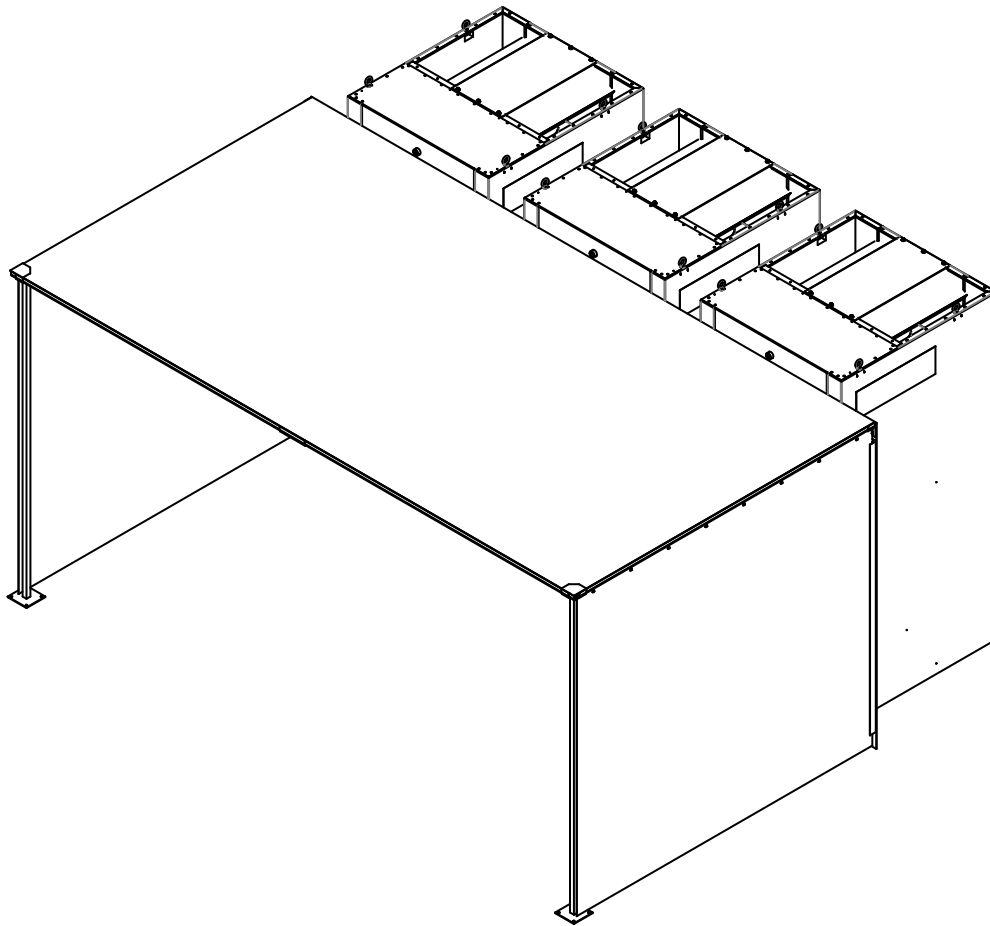

This manual contains specific precautions related to worker safety. The hazard alert image denotes safety related instructions and warnings in this manual. **DO NOT** install, operate, or perform maintenance on this collector until you have read and understood the instructions, precautions and warnings contained within this manual.

IMPORTANT NOTES

This manual has been supplied to assist with the installation, operation and maintenance for the collector purchased. Please read the manual before installing, operating, or performing maintenance on the collector as it contains specific precautions for worker safety. It is the owner's responsibility to ensure that this manual is available for use by installers, operators and maintenance personnel that will be working with this collector. This manual is the property of the owner and should be left with the collector when installation has been completed. **DO NOT** operate this collector until you have read and understood the instructions and warnings located in this manual.

For additional copies of this manual, contact Donaldson Torit.



The Safety Alert Symbol indicates a hazardous situation which, if not avoided could result in death or serious injury. Obey all safety messages following this symbol to avoid possible injury or death. The possible hazards are explained in the associated text messages.

NOTICE

The Notice symbol indicates a potential situation or practice which is not expected to result in personal injury, but which if not avoided may result in damage to equipment.

Contents

IMPORTANT NOTES	i
2 Product Description	3
3 Operation.....	4
4 Product Service	5
Operational Checklist	5
Dust Drawer.....	6
Filter Replacement	6
Light Bulb Replacement	7
Optional Afterfilter Replacement.....	7
Troubleshooting.....	8
Appendix A - Collector Installation.....	A1
Collector Installation	A2
Collector Location and Site Selection.....	A2
Provisional Anchor Bolt Recommendations	A2
Delivery and Inspection	A3
DWST 4-1 and 6-1 Single Power Module Installation	A4
DWST 4-2 to 4-4 and 6-2 to 6-4 Multiple Power Module Installation.....	A5
Acoustic Hard Sided Booth Assembly	A6
Soft Sided Acoustical Booth Assembly.....	A8
Compressed Air Installation.....	A9
Electrical Wiring.....	A9
Solid-State Timer Installation.....	A11
Optional Equipment	A15
Magnehelic® Gauge	A15
Photohelic® Gauge	A16
Delta P Control	A18
Delta P Plus Control	A18
Light Fixture	A18
Afterfilters	A18
Acoustic Curtain for Power Module	A19
Chamber Silencer.....	A19
IEC Control Panel with Programmable Logic Control	A20
IEC Control Panel Installation	A22
Sprinkler	A23
Start-Up/Commissioning Collector	A24
Decommissioning Collector	A26
Product Information	A27
Service Notes	A28
Donaldson Industrial Air Filtration Warranty.....	A30

Magnehelic® and Photohelic® are registered trademarks of Dwyer Instruments, Inc.

1 Safety Communication



Improper operation of dust collectors and/or dust control systems may contribute to conditions in a work area or facility which could result in severe personal injury, and product or property damage. All dust collection equipment should be used only for its intended purpose and should be properly selected and sized for its intended use.

Process owners have important responsibilities relating to identifying and addressing potential hazards in their processes. When the potential for handling combustible dust exists within a process the process owner should include combustion hazards in their risk management activities and should comply with applicable codes and standards related to combustible dust.

Electrical installation must be performed by a qualified electrician.

This equipment is not designed to support site ducts, piping, or electrical services. All ducts, piping, or electrical services must be adequately supported to prevent injury and/or property damage.

Site selection must account for wind, seismic zone, and other load conditions.

Equipment may reach peak sound pressure levels above 80 dB (A). Noise levels should be considered when selecting collector location.

Most dusts present safety and health hazards that require precautions. Wear eye, respiratory, head and other protection equipment suitable for the type of dust.

Some components may be heavier than they appear. Use appropriate lifting methods to avoid personal injury and/or property damage.

Combustible Dust Hazards

Among other considerations, the current NFPA standards require owners whose processes involve potentially combustible materials to have a current Dust Hazard Analysis, which can serve as the foundation for their process hazard mitigation strategy. Mitigation may include but is not limited to:

- Prevention of all ignition sources from entering any dust collection equipment.
- Selection and implementation of fire and explosion mitigation, suppression, and isolation strategies appropriate for the risks in their process.
- Development and use of work practices to maintain safe operating conditions, and to ensure combustible dust does not accumulate within their plant or process equipment.

Donaldson designs, manufactures, and sells industrial air filtration products for a wide variety of applications. Some applications may include processes or materials with inherent fire and explosion hazards. Donaldson is neither an expert nor a certified consultant in fire, spark, or explosion detection, suppression, or control. Donaldson does not provide engineering consulting services related to process or dust hazard analyses, or code and standard compliance. Complying with applicable codes and standards and managing the risks associated with the process or materials remains the responsibility of the process owner/operator. Donaldson may provide referrals to consultants, suppliers of equipment or services related to the detection and/or mitigation of sparks, fires and/or explosions, but Donaldson does not assume responsibility for any such referrals, nor does Donaldson assume any liability for the fitness of a mitigation strategy or product for a particular installation or application. The process owner's final selection of dust collectors and risk mitigation strategies should be based on the outcome of a Dust Hazard / Process Hazard Analysis performed by the process owner. Although early engagement of a dust collector supplier provides helpful insights on the availability and features of various products, process owners should consult with a combustible dust expert and/or a process safety expert before making actual product and mitigation strategy selections.

Donaldson recommends that all industrial air filtration system designs be reviewed and approved by an expert consultant who is responsible for the integrity of the system design and compliance with applicable codes and standards. It is the process owner's responsibility to understand the risks in their process and mitigate those risks in accordance with all applicable laws, regulations and standards, including those published by the NFPA. Donaldson also recommends that proper maintenance and housekeeping procedures and work practices be evaluated, developed, and followed to maintain any industrial air filtration products in safe operating condition.

Many factors beyond the control of Donaldson can affect the use and performance of Donaldson products in a particular application, including the conditions under which the product is used. Since these factors are uniquely within the user's knowledge and control, it is essential the user evaluate the Donaldson products to determine whether the product is fit for the particular purpose and suitable for the user's application. All products, product specifications, and data (airflow, capacity, dimensions, or availability) are subject to change without notice, and may vary by region or country.

2 Product Description

The Downflo WorkStation (DWST), is a continuous duty, self contained, modular workstation with cartridge style filters. Continuous duty means the filters can be pulse cleaned on-line without interrupting airflow through the collector. The filters are pulse-cleaned in sequence, one at a time, without turning the collector off. The modular design creates a custom collector for each application. The DWST power module includes a blower, two (2) dust drawers (available in either metal or plastic), a louver air inlet that can be located in a high or low position, and a ledge less design to reduce dust build up in the collector. Models DWST 4-1, 4-2, 4-3, 4-4, and DWST 6-1, 6-2, 6-3, 6-4 power modules can have joining strips to tie modules together.

Optional booths can be applied for all models. Designed to increase versatility of the collector, standard options include heavy duty wall and ceiling acoustic panels. They also include a ceiling light for each power module on hard sided and roof booths in dust tight or flush mounting lighting. Soft side weld and acoustical curtain booths are also available with a clear plastic ceiling to allow plant light to illuminate the booth. Also, a moveable side shield with canopy booth is available for one module and two module configurations.

Intended Use

The DWST is commonly installed in applications where dust containment from a specific operation is required. Typical applications include; abrasive blasting, batch mixing and grinding.

While the DWST effectively contains dust generated within the work area, it does not provide source capture of dust and some noise will be emitted from the booth. The 200 fpm indraft velocity produced by each power module is generally sufficient to prevent nuisance dust from escaping the DWST.

Abrasive Blasting

Abrasion-resistant options include an open louver inlet and smooth wall booth. Recommended options include: a control panel for reduced installation expense, flush lights for increased headroom, and ASHRAE or HEPA afterfilters to monitor primary filter performance for added safety on hazardous dust.

Batch Mixing

Dumping and mixing operations often produce significant amounts of nuisance or hazardous dust. The DWST provides effective dust control and allows complete freedom of movement. ASHRAE or HEPA afterfilters can be added to monitor primary filter performance for added safety on hazardous dust.

Grinding

The DWST gives the worker complete freedom of movement while grinding or moving around large or odd-shaped parts. Open-pleat Fibra-Web or Ultra-Tek® filters are required for the fibrous nature of composite dust. Recommended options include acoustic panels for a quieter work environment, control panel for reduced installation expense, flush lights for increased headroom, and HEPA afterfilters to monitor primary filter performance for added confidence on composite dust and for hazardous dust such as chromium, cadmium, and zinc.

3 Operation



Electrical work during installation, service or maintenance must be performed by a qualified electrician and comply with all applicable national and local codes.

Turn power off and lock out all power before performing service or maintenance work.

Turn compressed air supply off, bleed and lock out lines before performing service or maintenance work.

Check that the collector is clear and free of all debris before starting.

Do not install in classified hazardous atmospheres without an enclosure rated for the application.

During normal operation, the power module containing the blower draws dust-laden air from the work space through the filter cartridges. Dust collects on the outside surface of the filters. Clean, filtered air flows through to the center of the cartridge, through the clean-air plenum and into the blower silencer plenum. Filtered air exits through the top of the cabinet.

Filter cleaning is completed using pulse-jet technology. A solenoid valve controlled by a solid-state timer and a diaphragm valve aligned to each filter provides the pulse cleaning. The diaphragm valve sends a pulse of compressed air through the filter cartridge from the inside out and collected contaminants fall into the dust drawers. At the end of each pulse, the diaphragm valve closes and the filter cartridge resumes normal operation. One filter cartridge is cleaned per pulse.

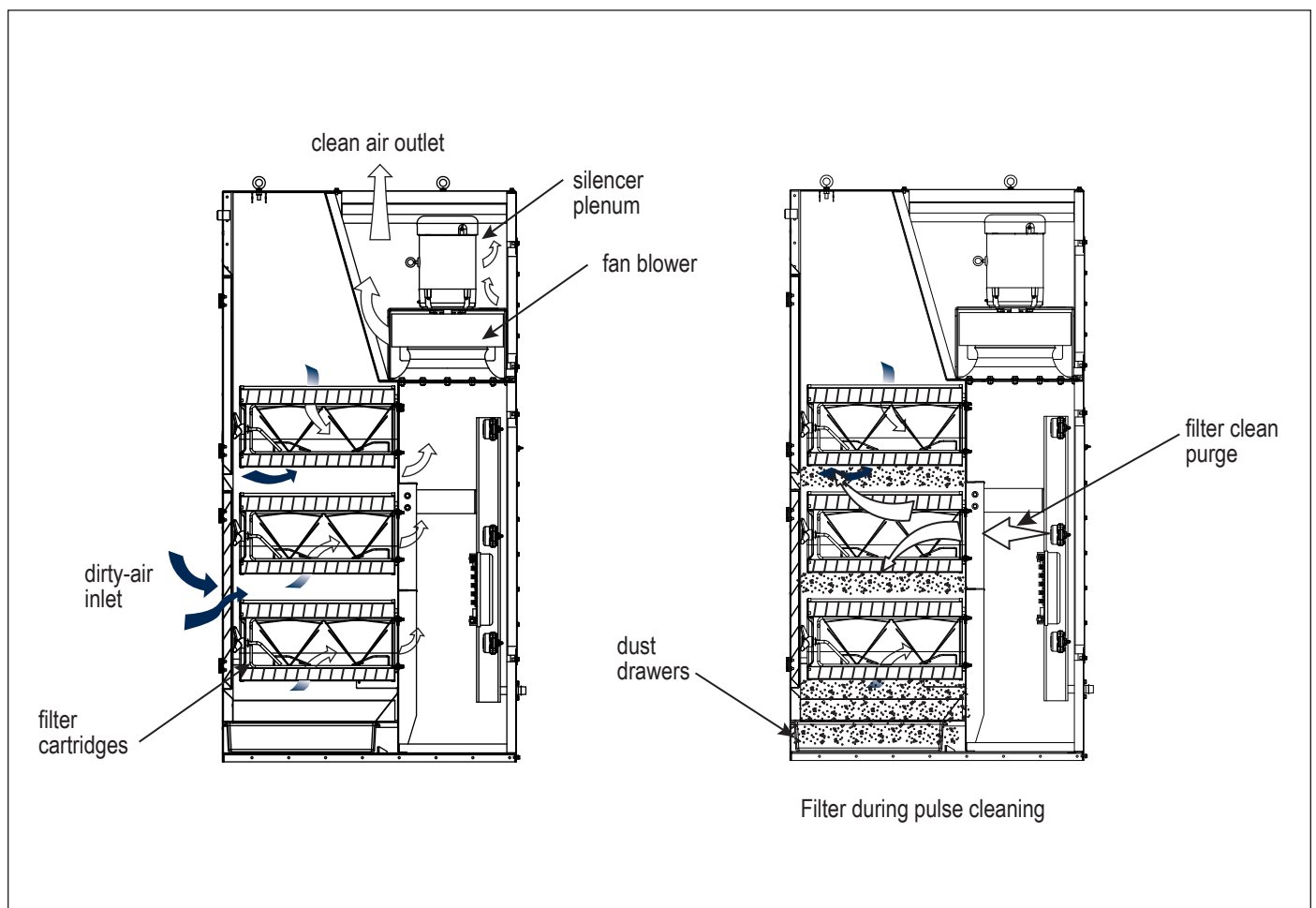

Collector Operation

4 Product Service



During any service activities there is some potential for exposure to the dust in the collector. Most dusts present safety and health hazards that require precautions. Wear eye, respiratory, head and other protection equipment suitable for the type of dust when performing any service activities.

Use appropriate access equipment and procedures. Note the standard collector is not equipped with access platforms unless noted on the specification drawings.

LOCK-OUT all energy sources prior to performing any service or maintenance on the equipment.

Electrical service or maintenance work must be performed by a qualified electrician and comply with all applicable national and local codes.

Turn compressed air supply OFF, bleed and lock out lines before performing service or maintenance work.

NOTICE

Do not set compressed-air pressure above 70-psig as component damage can occur.

All compressed air components must be sized to meet the system requirements of 50-70-psig supply pressure.

The compressed-air supply must be oil and moisture free. Contamination in the compressed air used to clean filters will result in poor cleaning, cleaning valve failure, or poor collector performance.

Purge compressed air lines to remove debris before connecting to the collector's compressed air manifold.

Operational Checklist

1. Monitor the physical condition of the collector and repair or replace any damaged components.

Routine inspections will minimize downtime and maintain optimum system performance. This is particularly important on continuous-duty applications.

2. Periodically check the compressed air components and replace compressed air filters.

Drain moisture following the manufacturer's instructions. With the compressed air supply ON, check the cleaning valves, solenoid valves, and tubing for leaks. Replace as necessary.

3. Monitor pressure drop across filters.

Abnormal changes in pressure drop may indicate a change in operating conditions and possibly a fault to be corrected. For example, prolonged lack of compressed air will cause an excess build-up of dust on the filters resulting in increased pressure drop. Cleaning off-line with no airflow usually restores the filters to normal pressure drop.

4. Monitor exhaust.

5. Monitor dust disposal. Empty the dust drawers at the end of each shift, or more frequently if necessary. Dust drawers should be emptied when they are more than 2/3 full.

6. Check fan wheel set screws. Set screws should be checked and retightened to 10.5 foot pounds for 3/8-in stainless steel set screws and 25 foot pounds for 1/2-in stainless steel set screws after eight hours of operation and again after 80 hours of operation.



Set screws on fan wheels must be properly tightened to avoid severe personal injury and/or property damage.

Dust Drawer

Dust drawers should be emptied at the end of each shift or more frequently if necessary (when 2/3 full).

1. Pull each dust drawer from the base of the power module.
2. Inspect and remove any residual dust from the base of the power module.
3. Cover the dust drawer to prevent leakage from the drawer during transport, and transport to an appropriate dust disposal location.
4. Empty the dust from the drawer into an appropriate disposal container
5. Return each drawer to the base of the power module, ensuring the drawers are both inserted fully to the back of the power module.

Filter Replacement



Most dusts present safety and health hazards that require precautions. Wear eye, respiratory, head and other protection equipment suitable for the type of dust.

Use proper safety and protective equipment when removing contaminants and filters.

Dirty filters may be heavier than they appear. Use appropriate lifting methods to avoid personal injury and/or property damage.

Turn power off and lock out all power before performing service or maintenance work.

Turn compressed air supply OFF, bleed and lock out lines before performing service or maintenance work.

Do not operate with missing or damaged filters.

1. Remove filter cartridges by removing the top and bottom access cover. Start with the top covers first.
2. Turn the knob counter clockwise. Remove access cover.
3. Break the seal between the filter cartridge and the sealing surface.
4. Slide each filter out the access port along the suspension yoke and dispose of properly.

NOTICE

Note the alignment of the filter to ensure the correct edge is up.

5. Clean any dust from the yoke threads that may have accumulated during the filter removal.
6. Inspect and clean the sealing surface of the tubesheet prior to installing a new filter.

NOTICE

Clean dust from gasket sealing area to ensure a positive filter gasket seal.

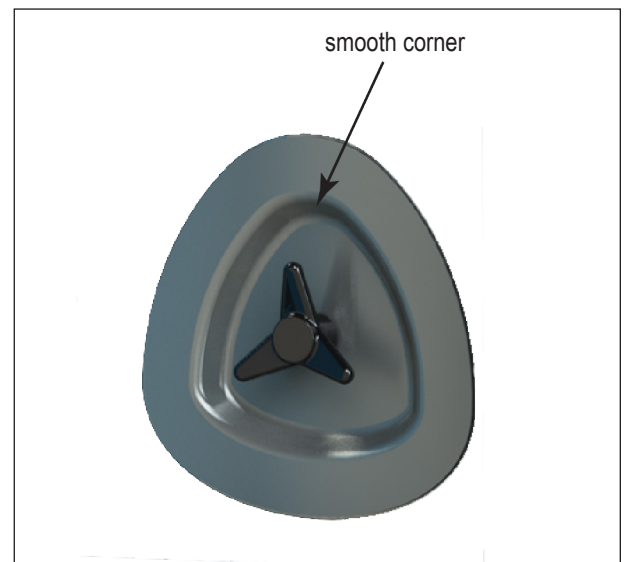

Triagonal Access Cover

7. Check for any accumulation of dust remove as necessary.
8. Install a new filter onto yoke with gasket oriented towards the collector.
9. Reinstall the access cover onto yoke. The smooth corner of the cover should be oriented towards the top as shown in the triangular access cover.
10. Engage knob and turn clockwise to seal the gasket on the filter to the tubesheet. Tighten knob by hand or tool.

NOTICE

The access cover must be properly aligned to ensure a dust tight seal to the housing.

Do not exceed 150-in- lbs (12.5 ft-lbs) torque when securing the access cover as over tightening may cause damage to the filter and/or equipment.

When filter replacement is complete, check to ensure that each access cover is seated and sealed against the filter housing to ensure a dust tight housing seal.

Light Bulb Replacement

This light fixture is serviced from inside the booth. Replace per the light manufacturers specifications.

Optional Afterfilter Replacement

1. Loosen the retaining screws and clamping straps and pull the afterfilters out of the frames.
2. Install the new afterfilters with the seal edge towards the power module cabinet. Airflow is from the inside of the plenum to the outside.
3. Position the clamping straps and tighten the wing screws to secure the new afterfilter.

Troubleshooting

Problem	Probable Cause	Remedy
Fan blower and motor do not start	Improper motor wire size	Rewire using the correct wire gauge as specified by national and local codes.
	Not wired correctly	Check and correct motor wiring for supply voltage. See motor manufacturer's wiring diagram. Follow wiring diagram and the National Electric Code.
	Collector not wired for available voltage	Correct wiring for proper supply voltage.
	Input circuit down	Check power supply to motor circuit on all leads.
	Electrical supply circuit down	Check power supply circuit for proper voltage. Check for fuse or circuit breaker fault. Replace as necessary.
	Damaged motor	Replace damaged motor.
Fan blower and motor start, but do not stay running	Incorrect motor starter installed	Check for proper motor starter and replace if necessary.
	Electrical circuit overload	Check that the power supply circuit has sufficient power to run all equipment.
Clean-air outlet discharging dust	Filters not installed correctly	See Filter Installation.
	Filter damaged or worn	Replace filters as necessary. Use only genuine Donaldson replacement parts. See Filter Installation.
	Access cover(s) loose	Tighten access doors securely. See Filter Replacement.
Insufficient airflow	Fan rotation backwards	Proper fan rotation is clockwise when viewed from the motor side or counterclockwise when viewed through the inlet cone. See Start-Up/Commissioning.
	Fan exhaust area restricted	Check fan exhaust area for obstructions. Remove material or debris. Adjust damper flow control.
High filter Delta P	New filters needed	Remove and replace using genuine Donaldson replacement filters. See Filter Replacement.
	Lack of compressed air	See Rating and Specification Information for compressed air supply requirements.
	Pulse cleaning not energized	Use a voltmeter to check the solenoid valves in the control panel. Check pneumatic lines for kinks or obstructions.
	Solid-State timer out of adjustment	See Solid-State Timer and Solid-State Timer Wiring Diagram.

Troubleshooting

Problem	Probable Cause	Remedy
High filter Delta P	Compressed air supply wet or oily	Bleed compressed air supply. Check for debris, valve wear, or diaphragm failure by removing the diaphragm cover on the pulse valves. Check for solenoid leaks or damage. If pulse valves or solenoid valves and tubing are damaged, replace.
	Pulse valves leaking compressed air	Lock out all electrical power to the collector and bleed the compressed air supply. Check for debris, valve wear, pneumatic tubing fault, or diaphragm failure by removing the diaphragm cover on the pulse valves. Check for solenoid leaks or damage. If pulse valves or solenoid valves and tubing are damaged, replace.
	Solid-State timer failure	Using a voltmeter, check supply voltage to the timer board. Check and replace the fuse on the timer board if necessary. If the fuse is good and input power is present but output voltage to the solenoid is not, replace the timer board. See Solid-State Timer Installation.
No display on the Delta P Controller	No power to the controller	Use a voltmeter to check for supply voltage.
	Fuse blown	Check the fuse in the control panel. See wiring diagram inside the control panel. Replace if necessary.
Display on Delta P Controller does not read zero when at rest	Out of calibration	Recalibrate as described in Delta P Maintenance Manual.
	With collector discharging outside, differential pressure is present from indoor to outdoor	Recalibrate with the pressure tubing attached as described in the Delta P Maintenance Manual.
Delta P Controller ON, but cleaning system does not start	Pressure tubing disconnected, ruptured, or plugged	Check tubing for kinks, breaks, contamination, or loose connections.
	Not wired to the timing board correctly	Connect the pressure switch on the timer board to Terminals 7 and 8 on TB3.
	Faulty relay	Using a multimeter, test relay for proper closure. Replace if necessary.

Problem	Probable Cause	Remedy
Control Box with Pulse Cleaning Control		
Pulse cleaning does not operate	Defective wiring	Check wiring to solenoid valves
	Defective solenoid valves	Check solenoid coils and replace as necessary.
	Timer control box not energized	Check supply voltage to timer board. Check the timer board's fuse. Replace with one of equal value. If supply voltage and fuse are good, observe the control board. The outlet LED indicates if the control board is attempting to pulse. LED's flash to indicate power to the solenoid. Check output with an analog volt meter using the 150-Volt AC scale. The needle deflects if voltage is present when LED flashes. If LED's do not flash or no voltage is present, replace the timer board.
Pulse cleaning does not operate with the selector switch in the ON position	Defective wiring	Check wiring to solenoid valves.
	Defective solenoid valves	Check solenoid coils and replace as necessary.
	Timer control board not energized	Check supply voltage to timer board. Check the timer board's fuse. Replace with one of equal value. If supply voltage and fuse are good, observe the control board. The outlet LED indicates if the control board is attempting to pulse. LED's flash to indicate power to solenoid. Check output with an analog volt meter using the 150-Volt AC scale. The needle deflects if voltage is present when LED flashes. If LED's do not flash or no voltage is present, replace the timer board.
Pulse cleaning does not operate with the selector switch in the GAUGE position	Defective wiring	Check wiring to solenoid valves.
	Defective solenoid valves	Check solenoid coils and replace as necessary.
	Timer control board not energized	Check supply voltage to timer board. Check the timer board's fuse. Replace with one of equal value. If supply voltage and fuse are good, observe the control board. The outlet LED indicates if the control board is attempting to pulse. LED's flash to indicate power to solenoid. Check output with an analog volt meter using the 150-Volt AC scale. The needle deflects if voltage is present when LED flashes. If LED's do not flash or no voltage is present, replace the timer board.
	Defective Photohelic air lines	Check tubing and fittings for leaks or obstructions.

Troubleshooting

Problem	Probable Cause	Remedy
NEMA Control Box with Starter, Pulse Control and Photohelic Gauge		
Pulse cleaning does not operate with the selector switch in the ON position	Defective wiring	Check wiring to solenoid valves.
	Defective solenoid valves	Check solenoid coils and replace as necessary.
	Timer control board not energized	Check supply voltage to timer board. Check the timer board's fuse. Replace with one of equal value. If supply voltage and fuse are good, observe the control board. The outlet LED indicates if the control board is attempting to pulse. LED's flash to indicate power to solenoid. Check output with an analog volt meter using the 150-Volt AC scale. The needle deflects if voltage is present when LED flashes. If LED's do not flash or no voltage is present, replace the timer board.
Pulse cleaning does not operate with the selector switch in the GAUGE position	Defective wiring	Check wiring to solenoid valves.
	Defective solenoid valves	Check solenoid coils and replace as necessary.
	Timer control board not energized	Check supply voltage to timer board. Check the timer board's fuse. Replace with one of equal value. If supply voltage and fuse are good, observe the control board. The outlet LED indicates if the control board is attempting to pulse. LED's flash to indicate power to solenoid. Check output with an analog volt meter using the 150-Volt AC scale. The needle deflects if voltage is present when LED flashes. If LED's do not flash or no voltage is present, replace the timer board.
	Defective Photohelic air lines	Check tubing and fittings for leaks or obstructions.
	Defective Photohelic gauge	Use a voltmeter and the wiring diagram to check for power at Terminals L1 and L2. If power is present, move setpoint indicators below gauge pressure reading. If pulsing does not begin when pressure exceeds the high setpoint, replace the gauge. If power is not present at Terminals L1 and L2, check the CR1 relay function.

Problem	Probable Cause	Remedy
NEMA Control Box with Starter, Pulse Control and Phothelic Gauge		
<p>Fan blower motor does not start</p> <p>If a fan blower motor fails to start or shuts down due to a short, overload or other fault, the panel indicates an alarm by flashing the RUNNING light. Two amber lights flash in a pattern indicating which circuit tripped the alarm.</p> <p>For example: The overload on the manual motor protector #3 trips. The RUNNING light starts flashing. The amber lights blink three times indicating the #3 motor. The alarm feature repeats itself until the STOP button is pressed and the circuit is reset.</p>	Improper motor wire size	Rewire using the correct wire gauge as specified by national and local codes.
	Not wired correctly	Check and correct motor wiring for supply voltage. See motor manufacturer's wiring diagram. Follow wiring diagram and the National Electric Code.
	Collector not wired for available voltage	Correct wiring for proper supply voltage.
	Branch circuit protection or overload tripped	Disconnect power using the disconnect switch. Press the black start button on the Manual Motor Protector, MMP. The red stop button should remain extended. The overload relay in the MMP resets automatically when the black start button is reset.
	Defective motor branch circuit protection or overload relay	Replace as necessary.
	Defective control transformer or control transformer branch circuit protection	Disconnect power using the disconnect switch. Check the control transformer T1, the primary fuse FU1, and the secondary fuse FU2. If fuses are good, check output voltage for 115-Volts. Replaced the transformer if output voltage is excessively high or low.

Troubleshooting

Problem	Probable Cause	Remedy
IEC Control Panel with Starter, PLC, and Magnehelic Gauge		
<p>Fan blower motor does not start</p> <p>If a fan blower motor fails to start or shuts down due to a short, overload or other fault, the panel indicates an alarm by flashing the RUNNING light. Two amber lights flash in a pattern indicating which circuit tripped the alarm.</p> <p>For example: The overload on the manual motor protector #3 trips. The RUNNING light starts flashing. The amber lights blink three times indicating the #3 motor. The alarm feature repeats itself until the STOP button is pressed and the circuit is reset.</p>	Improper motor wire size	Rewire using the correct wire gauge as specified by national and local codes.
	Not wired correctly	Check and correct motor wiring for supply voltage. See motor manufacturer's wiring diagram. Follow wiring diagram and the National Electric Code.
	Collector not wired for available voltage	Correct wiring for proper supply voltage.
	Branch circuit protection or overload tripped	Disconnect power using the disconnect switch. Press the black start button on the Manual Motor Protector, MMP. The red stop button should remain extended. The overload relay in the MMP resets automatically when the black start button is reset.
<p>Pulse cleaning does not operate</p>	Defective motor branch circuit protection or overload relay	Replace as necessary.
	Defective control transformer or control transformer branch circuit protection	Disconnect power using the disconnect switch. Check the control transformer T1, the primary fuse FU1, and the secondary fuse FU2. If fuses are good, check output voltage for 115-Volts. Replace the transformer if output voltage is excessively high or low.
	Defective wiring	Check wiring to solenoid valves.
<p>Pulse cleaning does not operate</p>	Defective solenoid valves	Check solenoid coils and replace as necessary.
	PLC output is not energized or is defective	Check supply voltage to the PLC timer. If voltage is not present at PLC Terminals L and N, check the control transformer fuses FU1 and FU2. Observe the output LED's corresponding to the wiring diagram. Set the selector switch SW1 to ON. The LED's flash in sequence indicating the PLC is pulsing the solenoid valves. Check the output voltage between neutral N, 302, 303, and remaining solenoid connections using an analog voltmeter set to the 150-Volt AC scale. The needle deflects if voltage is present when LED flashes. If LED's do not flash or no voltage is present, replace the PLC.
	Lack of compressed air	Maintain 50-60 psig. Adjust as necessary.

Problem	Probable Cause	Remedy
IEC Control Panel with Starter, PLC, and Magnehelic Gauge		
Aftershift pulse not working properly	Not wired correctly	Check and correct motor wiring for supply voltage. See motor manufacturer's wiring diagram. Follow wiring diagram and the National Electric Code.
	Blown fuse	Check the transformers primary and secondary fuses FU1 and FU2.
	Lack of compressed air	Maintain 50-60 psig. Bleed compressed air supply. Check for debris, valve wear, or diaphragm failure by removing the diaphragm cover on the pulse valves. Check for solenoid leaks or damage. If pulse valves or solenoid valves and tubing are damaged, replace.
Push buttons do not work, no pulse cleaning	Loss of power	Check disconnect, fuses and transformer
	Defective PLC	Check that the power LED, POW is lit. If neither or only one LED is lit, replace the PLC. Check error LED's, ERR1 and ERR2. If lit, replace the PLC.

Appendix A - Collector Installation

Collector Installation



Electrical installation (including bonding and grounding of the collector) must be performed by a qualified electrician.

This equipment is not designed to support site ducts, piping, or electrical services. All ducts, piping, or electrical services must be adequately supported to prevent injury and/or property damage.

Do not install in classified hazardous atmospheres without an enclosure rated for the application.

Service must be performed by trained and qualified maintenance personnel.

Equipment may reach peak sound pressure levels above 80 dB (A). Noise levels should be considered when selecting collector location.

Collector Location and Site Selection

Equipment location must conform to all codes and standards, should be suitable for the type of dust being handled and should ensure easy access for service and utility connections. Site selection must account for wind, seismic zone, and other load conditions. Collector is intended for indoor installation.

The equipment must be anchored once in final position. Foundation or support framing must be capable of supporting dead, live, wind, seismic and other applicable loads. Consult a qualified engineer for final selection of foundation or support framing.

Provisional Anchor Bolt Recommendations

The quantity of anchor bolts should match the number of holes provided in the base of the collector. Anchor diameter is typically 1/8-inch less than the base hole diameter.

Delivery and Inspection

Upon arrival inspect collector and report any damage to delivery carrier. File any damage claims with the delivery carrier. Request a written inspection report from the Claims Inspector to substantiate all damage claims.

Compare the collector received with the description of product ordered. Report any incomplete shipments to the delivery carrier and your Donaldson Torit representative.

Unloading and Positioning (Collectors are generally packaged and shipped laying on their side)



Collector should be lifted only by qualified crane or fork truck operators.

Failure to lift the collector correctly can result in severe personal injury and/or property damage.

Label on pack slip and bill of lading will state weight of the collector as delivered.

1. Lift the packaged collector from transport container.
2. Remove any crates or shipping straps.
3. Use all lifting points provided.
4. Use clevis connectors, not hooks, on lifting slings.
5. Use spreader bars to prevent damage to collector's casing.
6. Check the Specification Control drawing for weight and dimensions of the collector and components to ensure adequate crane capacity.
7. Inspect for any damage and/or missing parts and report to freight carrier.
8. Check for any hardware which may have become loose during shipment and tighten as necessary.

Lift collector and accessories separately and assemble after collector is in place.

Use drift pins to align holes in section flanges during assembly.

DWST 4-1 and 6-1 Single Power Module Installation

1. Install all lifting eyes (Four (4) per power module). Lifting eyes are shipped loose and install on roof of DWST.
2. Connect lifting sling or chains to the four lifting eyes located on the roof of the DWST.
3. Move the power module into position. Provide a minimum of 24-inches between rear side of collector and the wall for product maintenance.

Note: Using the bolt hole plug pack, shipped loose, plug the bolt holes on the power module face with M8 x 20 mm bolts and washers provided.
4. Lifting eyes can be removed once collector is in place to install more power modules and for mounting accessories on roof.

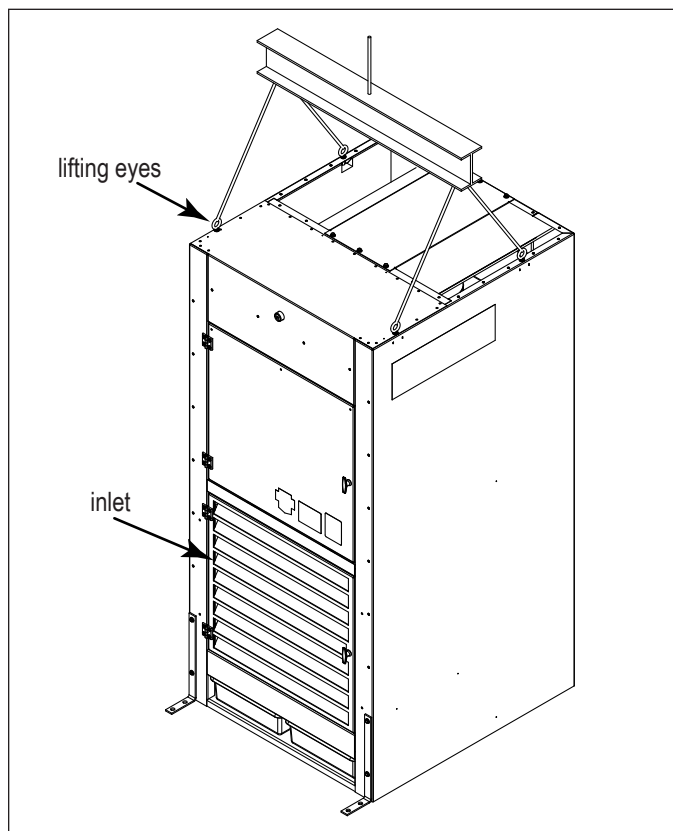

DWST 4-1 and 6-1 Single Power
Module Installation

DWST 4-2 to 4-4 and 6-2 to 6-4 Multiple Power Module Installation

1. Connect lifting sling or chains to the four lifting eyes located on the roof of the power module.
2. Position the modules side by side. Position the first power module, remove the lifting eyes before positioning the next power module, as the lifting slings and chains can interfere.
3. Secure the power modules together using the joining strips, bolt hole plug pack, M8 x 20 mm bolts, and flat washers.
4. Lifting eyes can be removed once collector is in place to install more power modules and for mounting accessories on roof.

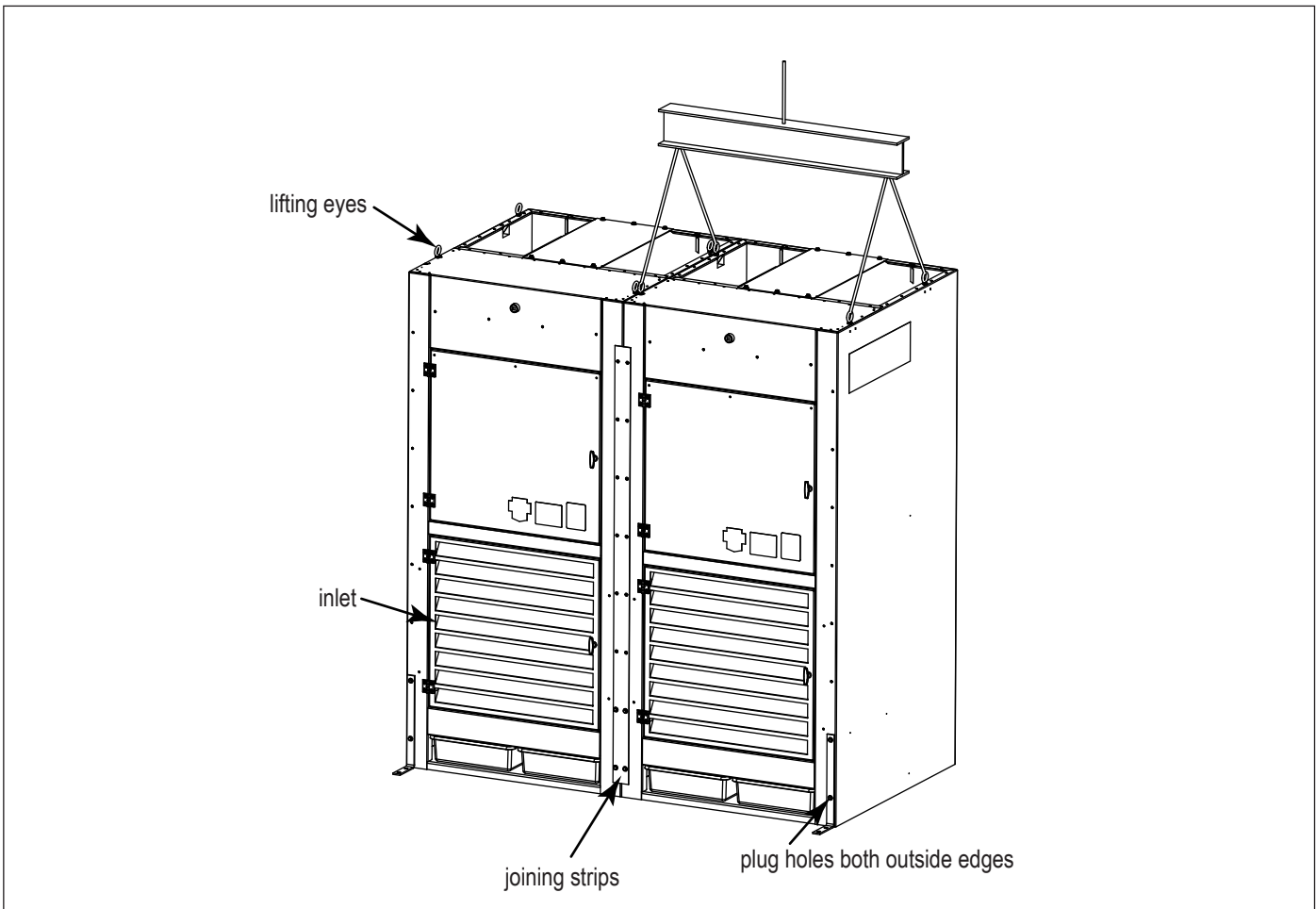

DWST 4-2 to 4-4 and 6-2 to 6-4 Multiple Power Module Installation

Acoustic Hard Sided Booth Assembly

Note: Use M8 x 45 mm bolts to fasten the side rail channels.

Use M8 x 35 mm bolts to fasten the top support channels.

Use M8 x 20 mm bolts for the remainder of the assembly.

1. Fasten the module side angles to the right and left side of the assembled power modules.
2. Fasten the top panel angle to the top front of each power module.
3. Assemble two booth panels and a side panel angle to form a wall collector.
4. Attach wall to the outside of the power module side angle.
5. Fasten the side-rail channels to the wall using M8 x 45 mm long bolts, flat washers, and hex nuts.

Note: The side-rail channel with four bolt holes fits on the outside bottom of the walls and the side-rail channel with three bolt holes fits on the inside of the walls about midway up. Do not fasten the inside channel until the acoustic panels have been installed.

6. Bolt the gussets to the right and left support legs and fasten the support legs to the edge of the corresponding walls.
7. Bolt the top support channel to the gussets.

Note: The DWST-2 requires one top support channel. DWST-3 and DWST-4 require two top support channels. When assembling the DWST-3 or DWST-4, bolt the two top support channels and the top support tie-in together and then bolt to the gussets.



Roof panels are not intended as platforms. Personnel should use ladders or other appropriate equipment to avoid risk of personal injury and/or property damage.

8. Install and bolt the booth roof panels in place.

Note: Temporary roof support is required on larger booth assemblies. The top panel angles and the top support channels support the roof panels.

9. Attach the splice plate to the top panel angles with the roof panels.
10. Install the acoustic panels to the power modules, booth roof, and walls.
11. Secure acoustic panels with nylon Christmas Tree™ clips supplied.
12. Install flexible protective caps over exposed end of Christmas Tree clips.
13. Tuck the edges of the booth acoustic panels into the return flanges of the booth panels.
14. See light fixture mounting and wiring.
15. Anchor last holes from power module.

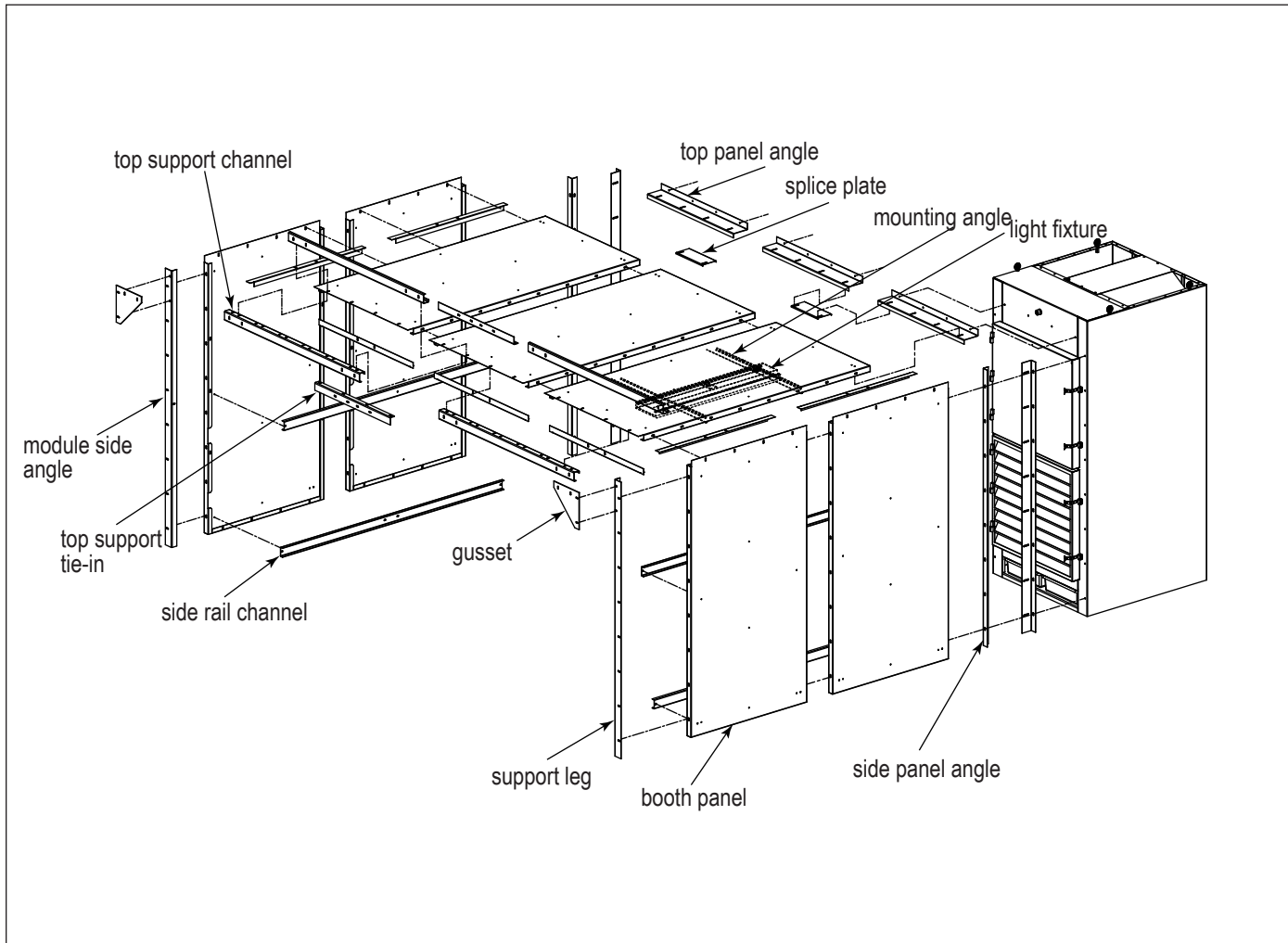

Acoustic Hard Sided Booth Assembly

Soft Sided Acoustical Booth Assembly

DWST Models 4-2, -3, -4

1. Position the power modules in-line so fronts are even and two sides are touching face-to-face. Position the first power module and remove lifting eyes, repeat this for each additional power module.
2. Remove and reuse the existing bolts and washers to install the joining strips in between the power modules.

DWST Models 6-2, -3, -4

1. For DWST Models 6-2 and -3, check assembly drawings for power module spacing positions. Also, a spacer panel will need to be installed in between the power modules on these models. See drawings for details.
2. Install the side panels on each end of the power module assembly. Remove and reuse the existing bolts and washers on the front of the cabinet.

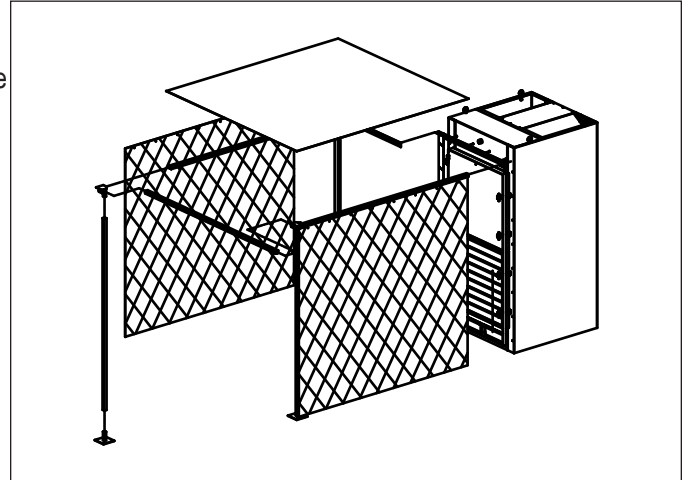

Soft Sided Acoustical Booth

DWST Models 4 and 6

3. Install the side and top angles (3 places) with the existing hardware from the front of each power module. Attach the end brackets (2 places) to the outer ends of each power module with the provided hardware.

Note: for the DWST Models 4-2, -3, -4 only- Four (4) holes will need to be drilled in the front panel of the power module in order for the end brackets to be attached. See Bracket Detail for hole location and size.

4. Install the mounting angles (2 places) just below the sprinkler couplings on the power module. Remove and reuse the existing bolts and washers.
5. Insert the foot pad and corner bracket into the front legs.
6. Insert the eight (8) roller hooks into the side channel. Install one end of the side channel into the end bracket mounted to the power module. The other end of the side channel should be installed into the corner bracket. Repeat these steps for the opposite side of the collector.
7. Install each end of the front channel into the corner brackets on each of the front legs. The front channel should extend past the side channels in order to lock in the roller hooks. Square the entire frame assembly and tighten all set screws on the end, corner, and coupling brackets. Anchor the leg foot pad to the floor.

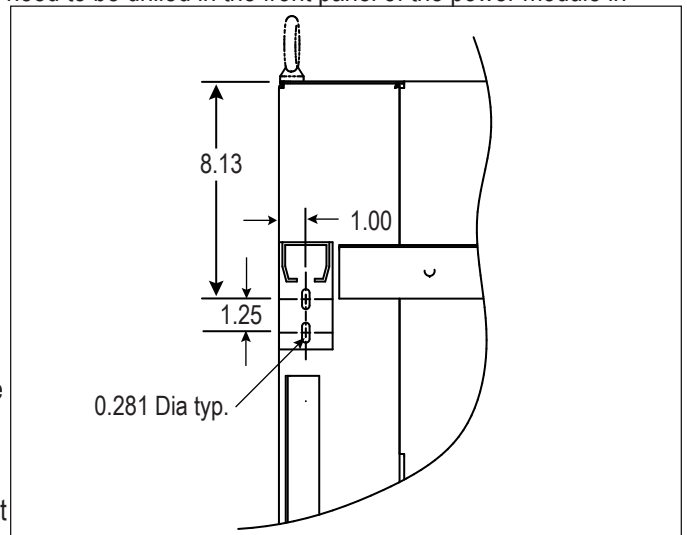

Bracket Detail

8. Install the self-adhesive Velcro strip around the top of the channels and angles on the power module. Install the clear plastic roof.
9. Install the self-adhesive Velcro strip down the outside of the side angles (2 places) and on the outside surface of the front legs. Hang the tinted side curtain on the roller hooks. Attach the side curtain to the Velcro strips. Repeat this for the opposite side of the booth assembly.

Compressed Air Installation



Turn compressed air supply OFF, bleed and lock out lines before performing service or maintenance work.

A safety exhaust valve should be used to isolate the compressed air supply. The safety exhaust valve should completely exhaust pressure in the collector manifolds when closed, should be capable of being interlocked with fire or explosion mitigation equipment and should include provisions to allow closed-position locking.

NOTICE

Do not set compressed-air pressure above 70-psig as component damage can occur.

All compressed air components must be sized to meet the system requirements of 50-psig supply pressure.

The compressed-air supply must be oil and moisture free. Contamination in the compressed air used to clean filters will result in poor cleaning, cleaning valve failure, or poor collector performance.

Purge compressed-air lines to remove debris before connecting to the collector's compressed-air manifold.

1. Connect the compressed-air supply line to the 1-in NPT connection located at the rear of each power module. Use thread-sealing tape or pipe sealant on all compressed-air connections.
2. Install a customer-supplied shut-off valve, bleed-type regulator with gauge, filter, and automatic condensate valve in the compressed-air supply line.
3. With power supply ON, check the operation of the solenoid valves. The valves should open and close sequentially at factory set 10-second intervals.
4. If a Photohelic® gauge, Torit Delta P, Torit Delta P Plus, or similar device is used to control the solid-state timer, the solenoid valves pulse only when the differential pressure reaches the high-pressure setpoint. The valves continue to pulse until the low-pressure setpoint is reached. The Torit Delta P Plus will also initiate a downtime clean if the low setpoint has been reached.

Electrical Wiring



Electrical installation, service, or maintenance work must be performed by a qualified electrician and comply with all applicable national and local codes.

Turn power off and lock out all power before performing service or maintenance work.

Do not install in classified hazardous atmospheres without an enclosure rated for the application.

All electrical wiring and connections, including electrical grounding, should be made in accordance with the National Electric Code (NFPA No. 70-latest edition).

Check local ordinances for additional requirements that apply.

The appropriate wiring schematic and electrical rating must be used. See collector's rating plate for required voltage.

An electric disconnect switch having adequate amp capacity shall be installed in accordance with Part IX, Article 430 of the National Electrical Code (NFPA No. 70-latest edition). Check collector's rating plate for voltage and amperage ratings.

Refer to the wiring diagram for the number of wires required for main power wiring and remote wiring.



Turn power off and lock out electrical power sources.

Turn compressed air supply OFF, bleed and lock out lines before performing service or maintenance work.

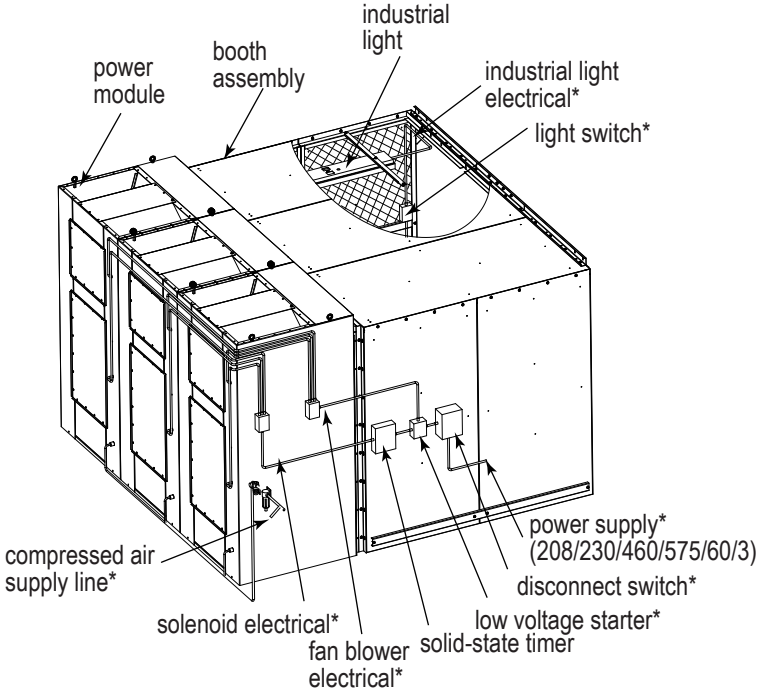

sprinkler system (not shown)*
*customer supplied

Compressed Air and Component Installation

Solid-State Timer Installation

The solid-state timer is an electronic timer used to control the filter cleaning system. Each power module is equipped with four or six 115-Volt AC solenoid valves that energize the diaphragm valves to pulse-clean the filter cartridges. The timer is factory adjusted at 100-millisecond ON time and 10-second OFF time between pulses.

1. Mount the fan starter with low voltage control in a convenient location.
2. Mount the control box as close to the blower motor starter as possible.
3. Using the wiring diagram supplied, wire the blower motor, blower-motor starter, solid-state timer, and solenoid valves. Use appropriate wire gauge for rated amp load as specified by local codes.

Note: Access the solenoid valves and blower motor by removing the access covers at the rear of the power module. After wiring is complete, replace the covers.

Route wiring through the conduit holes located at the rear of the power module. All conduit holes are sized for 3/4-in fittings. Secure all conduit in the blower and solenoid plenums.

4. Diaphragm valves have an external solenoid enclosure mounted inside the clean air plenum on the pressure manifold. Wire each solenoid in the enclosure mounted on the compressed air manifold per the wiring diagram provided. Pull the cover from the solenoid enclosure. Wire solenoids through access points in rear of cabinet and enclosure by referencing wiring diagram.
5. Motor and fan should be wired for clockwise rotation when viewed from the back of the motor.

To reverse rotation, three-phase power supply:

Turn electrical power OFF at source and switch any two leads on the motor junction box.



Do not look into fan outlet to determine rotation. View the fan rotation through the back of the motor.

Check that the exhaust plenum is free of tools or debris before checking blower/fan rotation.

Stand clear of exhaust to avoid personal injury.

Do not interchange a power lead with the ground wire. Severe damage or personal injury may result.

6. Turn the blower motor ON then OFF. Check for clockwise rotation when viewed from the back of the motor.
7. Turn blower fan motor ON.

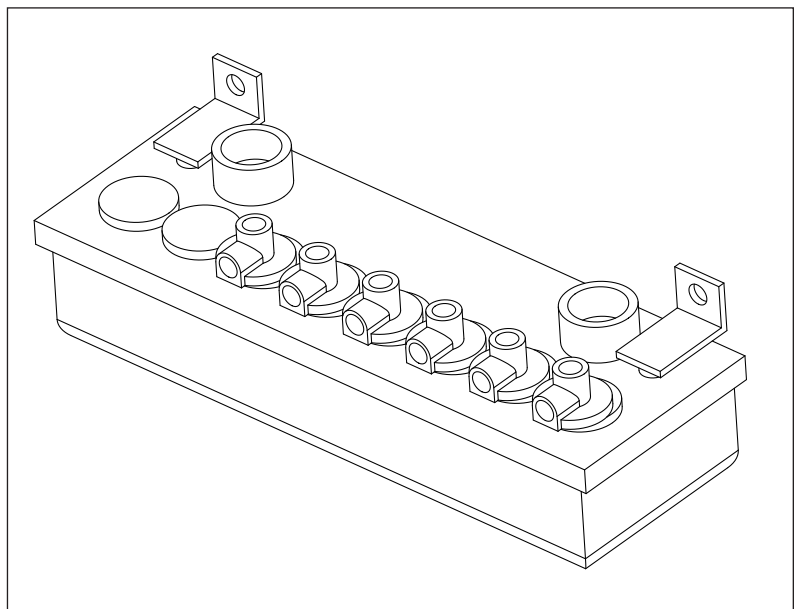

Solenoid Enclosure

Input
105-135V/50-60Hz/1Ph

Output Solenoids
The load is carried and turned ON and OFF by the 200 watt maximum-load-per-output solid-state switch.

Pulse ON Time
Factory set at 100-milliseconds, or 1/10-second.

NOTICE Do not adjust pulse ON time unless the proper test equipment is available. Too much or too little ON time can cause shortened filter life.

Pulse OFF Time
Factory set at 10-seconds, adjustable from 1 to 1.5-second minimum to maximum 60 to 66-seconds.

Operating Temperature Range
-20° F to 130° F

Transient Voltage Protection
50 kW transient volts for 20-millisecond duration once every 20 seconds, 1% duty cycle.

Solenoid Valves
115-Volt at 19.7 watts each

Compressed-Air
Set compressed-air supply pressure to a level suitable for the filters (50-psig). The pulse-cleaning controls are factory set to clean one or more filters every 10-seconds during a cleaning cycle.

NOTICE Do not increase supply pressure above 70-psig as component damage can occur.

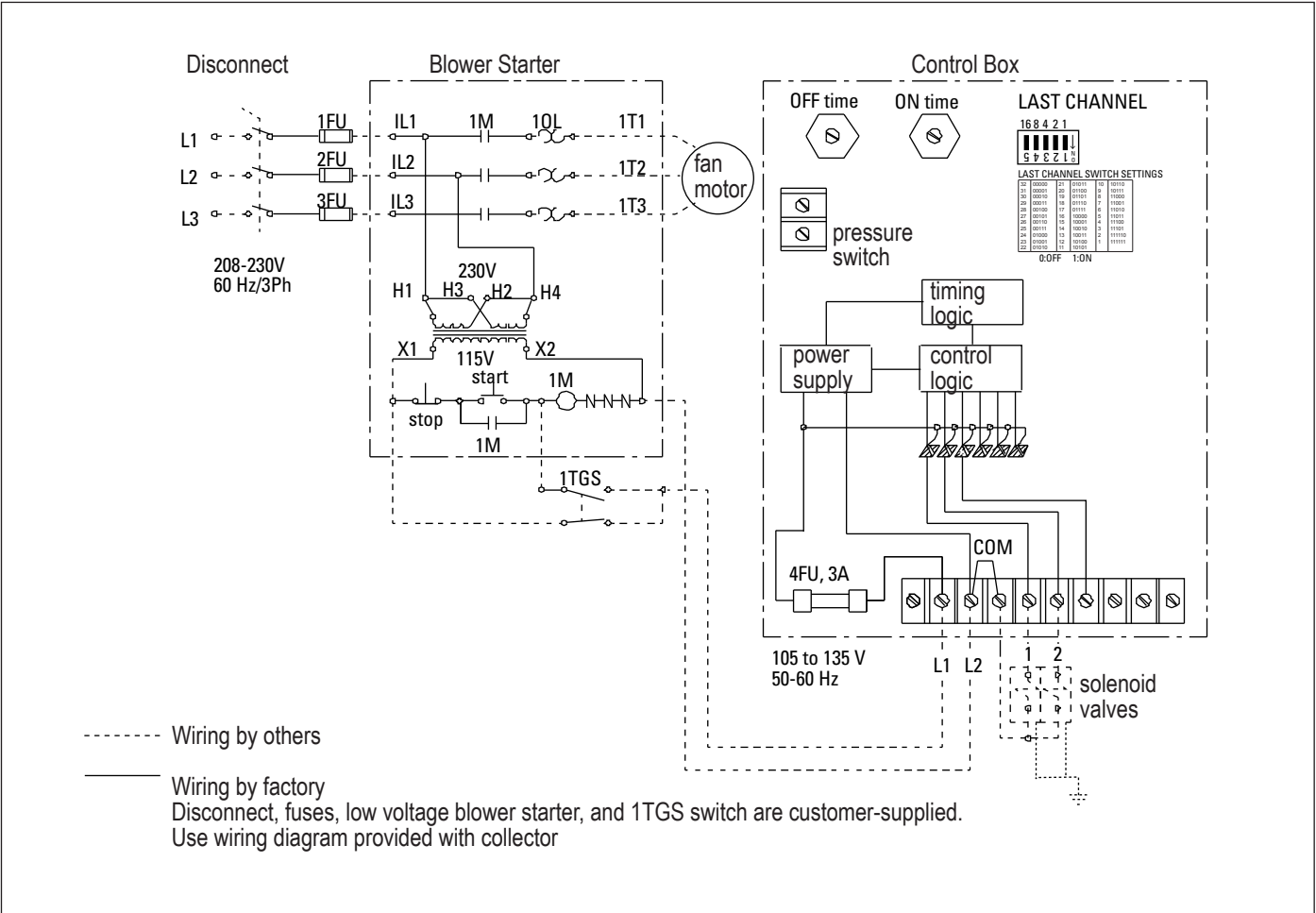

Solid-State Timer Typical Wiring Diagram

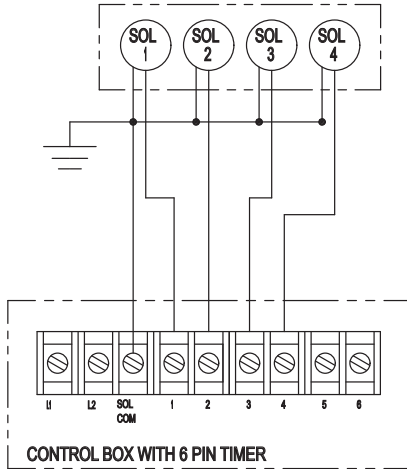

DWST 4-1

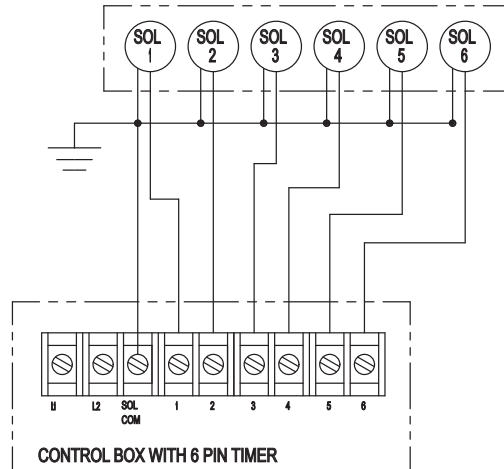

DWST 6-1

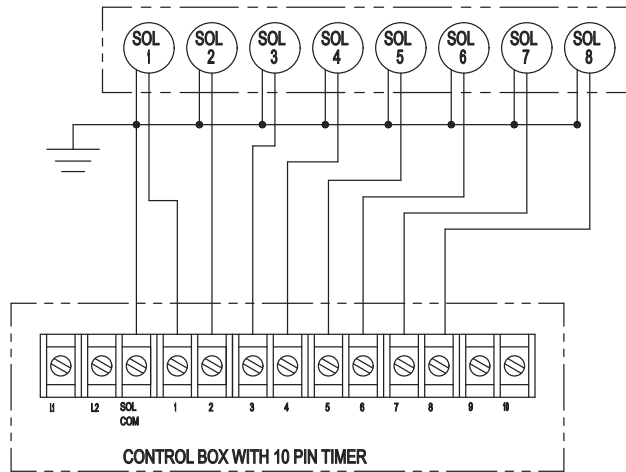

DWST 4-2

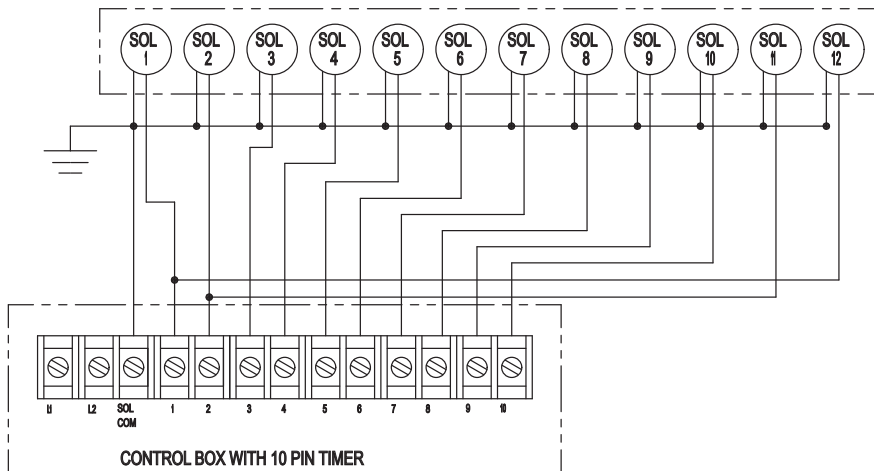

DWST 4-3 & DWST 6-2

Wiring Diagram, Control Box Timer to Solenoids

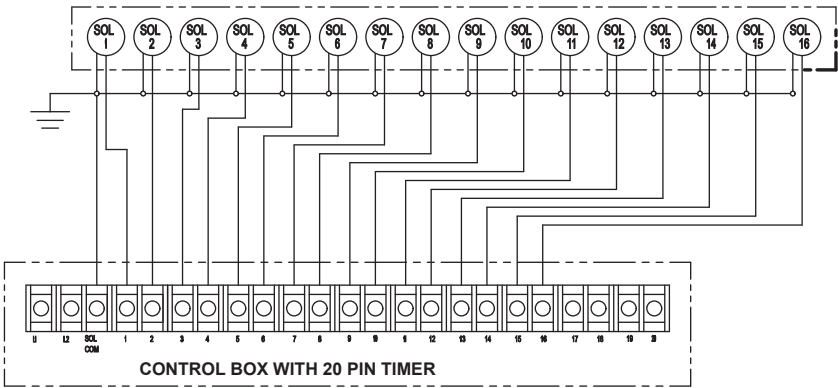

DWST 4-4

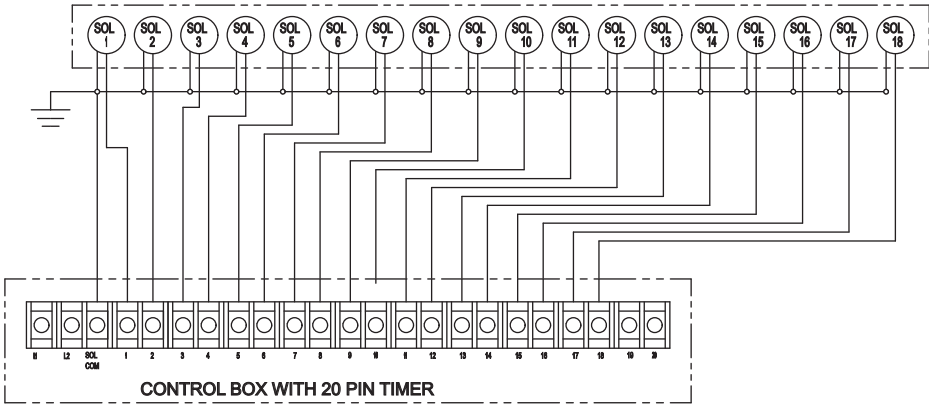

DWST 6-3

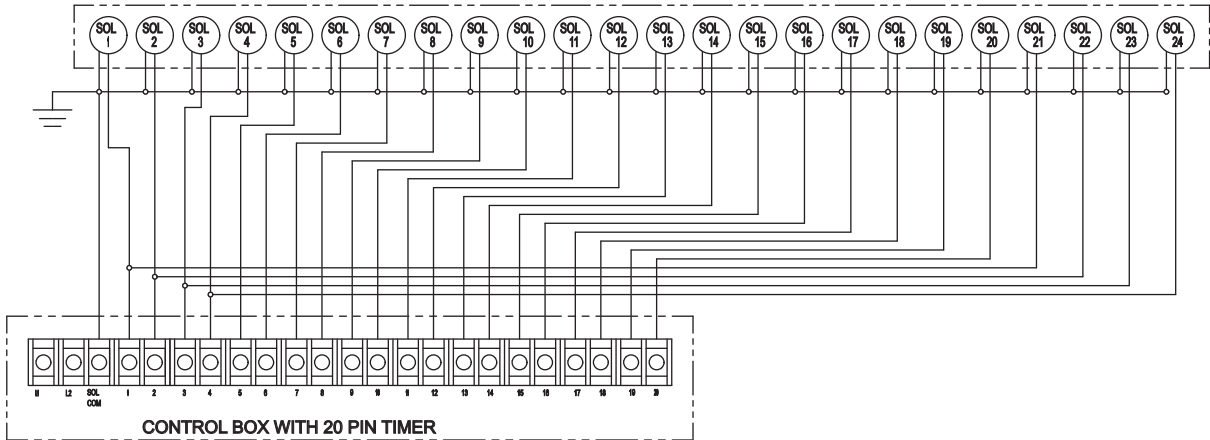

DWST 6-4

Wiring Diagram, Control Box Timer to Solenoids

Optional Equipment

Magnehelic® Gauge

The Magnehelic is a differential pressure gauge used to measure the pressure difference between the clean-air and dirty-air plenums and provides a visual display of filter change requirements. The high-pressure tap is located in the dirty-air plenum and the low-pressure tap is located in the clean-air plenum.

1. Choose a convenient, accessible location on or near the collector for mounting that provides the best visual advantage.
2. Plug the pressure ports on the back of the gauge using two, 1/8-in NPT pipe plugs supplied. Install two, 1/8-in NPT male adapters supplied with the gauge into the high- and low-pressure ports on the side of the gauges.
3. Attach the mounting bracket using three, #6-32 x 1/4-in screws supplied.
4. Mount the gauge and bracket assembly to the supporting structure using two, self-drilling screws.
5. Thirty-five feet of plastic tubing is supplied and can be cut as needed. Connect tubing from the gauge's low-pressure port to the fitting in the clean-air plenum. Leave high-pressure port open to the atmosphere. Additional tubing can be ordered from your representative.
6. Zero and maintain the gauge as directed in the manufacturer's Operating and Maintenance Instructions provided.

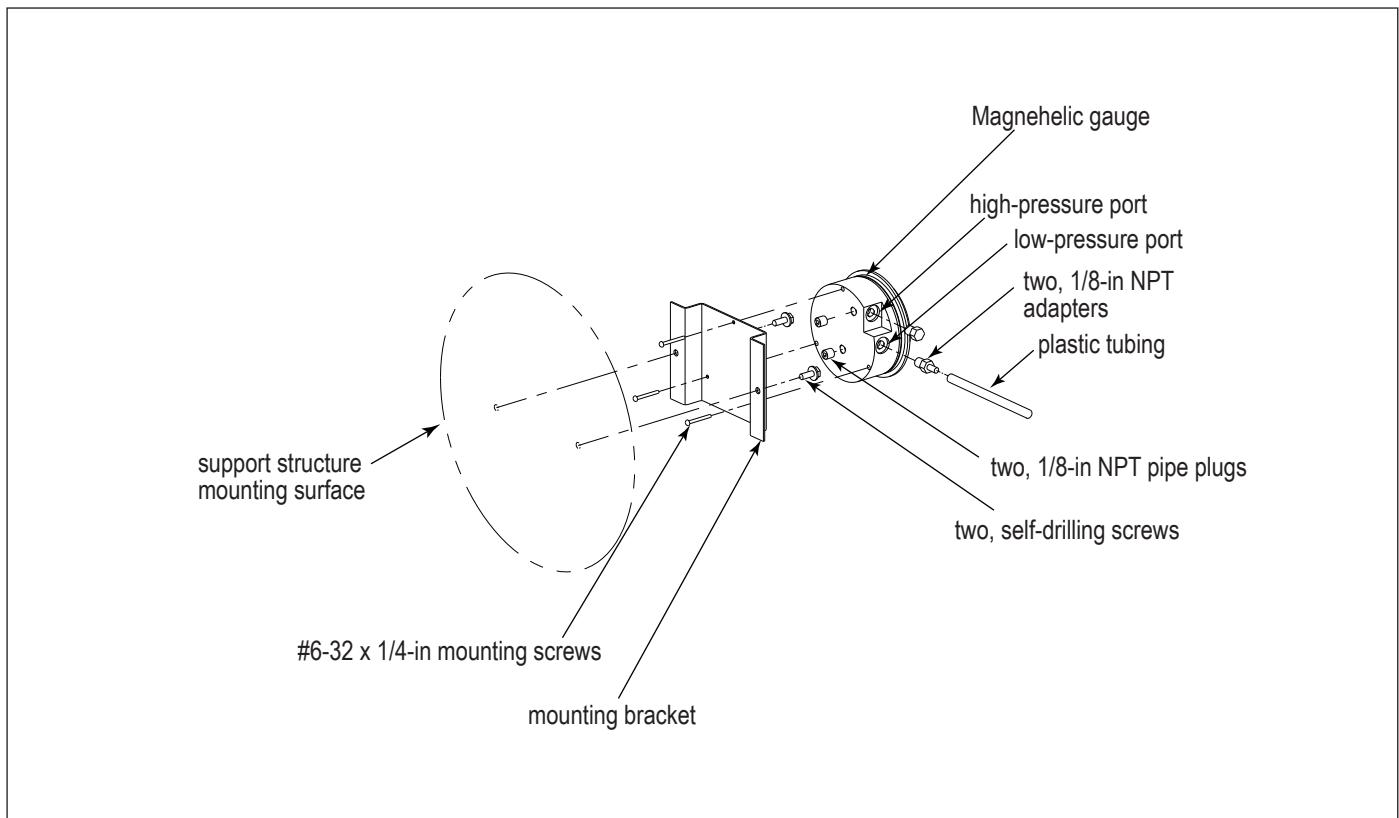

Magnehelic Gauge Installation

Photohelic® Gauge



Electrical installation, service, or maintenance work must be performed by a qualified electrician and comply with all applicable national and local codes.

Turn power off and lock out all power before performing service or maintenance work.

Do not install in classified hazardous atmospheres without an enclosure rated for the application.

The Photohelic combines the functions of a differential pressure gauge and a pressure-based switch. The gauge function measures the pressure difference between the clean and ambient air and provides a visual display of filter condition. The low-pressure tap is located in the clean-air plenum on the back of the cabinet. The pressure-based switch function provides high-pressure ON and low-pressure OFF control of the filter cleaning system.

1. Choose a convenient, accessible location on or near the collector for mounting that provides the best visual advantage.
2. Mount the gauge to the remote panel or door using the mounting ring, retaining ring, and four #6-32 x 1/4-in screws. Do not tighten screws. Connect one 1/8-in NPT x 1/4-in OD male adapter to the low-pressure port of the gauge. Leave high-pressure port open to the atmosphere. Align the adapter to the 2.375-in hole in the right-hand side of the mounting bracket. Tighten screws.
3. Zero and maintain the gauge as directed in the manufacturer's Operating and Maintenance Instructions provided.

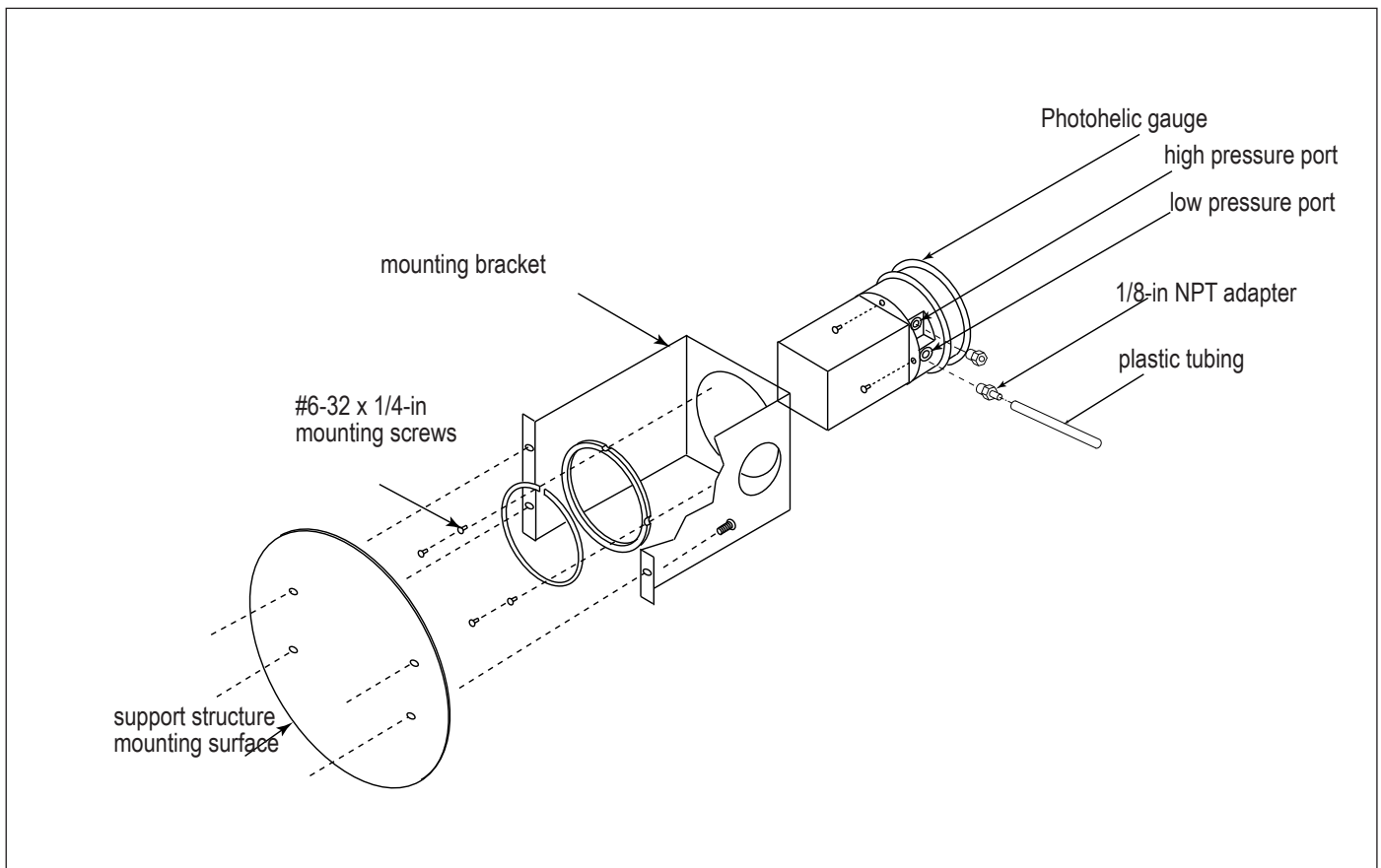

Photohelic Gauge Installation

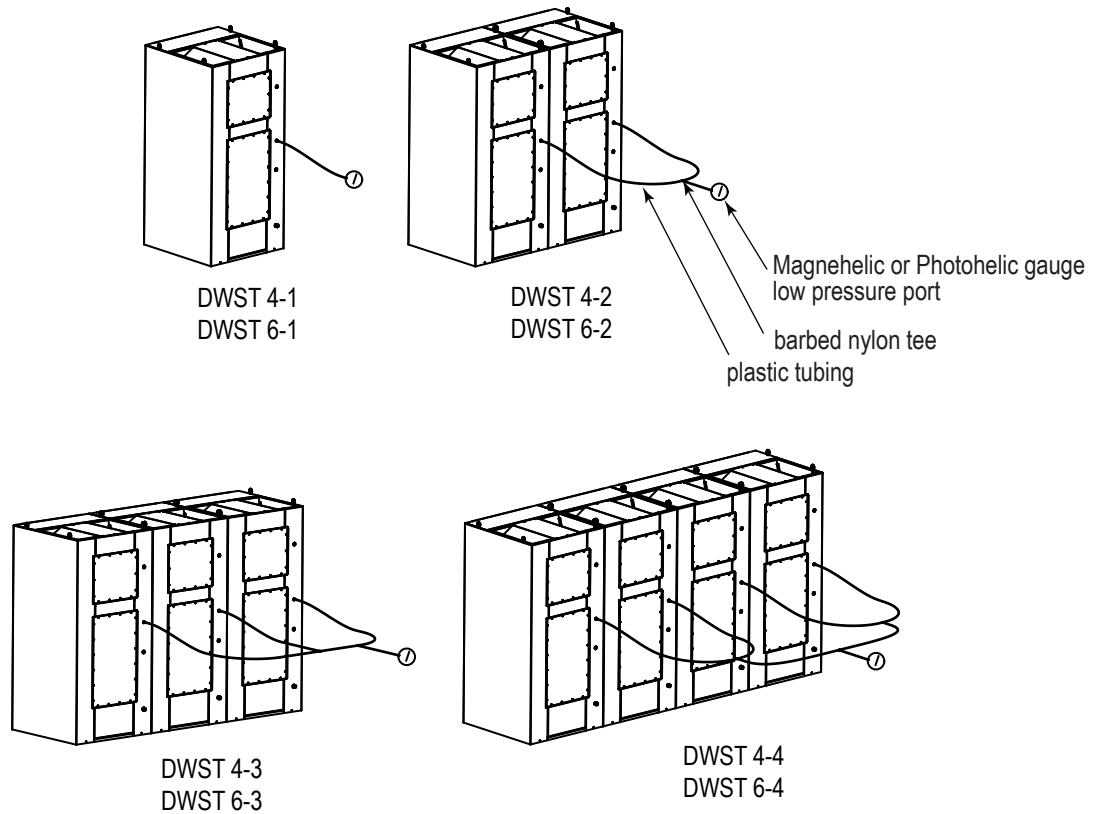

Magnehelic and Photohelic Gauge and Tubing Installation

Delta P Control

For complete information, see the most current version of the Delta P Installation, Operation and Maintenance manual.

Delta P Plus Control

For complete information, see the most current version of the Delta P Installation, Operation and Maintenance manual.

Light Fixture



Electrical work must be performed by a qualified electrician and comply with all applicable national and local codes.

Turn power off and lock out electrical power sources before performing service or maintenance work.

Do not install in classified hazardous atmospheres without an enclosure rated for the application.

Wire the fixture following the wiring diagram included with the fixture.

Afterfilters

1. Place 1/4-in diameter rope-type sealant to the top flange of the power module.
2. Position the afterfilter plenum on the power module with the vertically mounted afterfilter facing over the booth.
3. Fasten using M8 x 20 mm bolts and flat washers.
4. Install the afterfilters in the afterfilter frame.
5. Install HEPA filters with the filter gasket toward the inside of the frame.
6. Install ASHRAE filters with the airflow arrow pointing to the outside.
7. Position the clamping straps and tighten the wing screws securely.

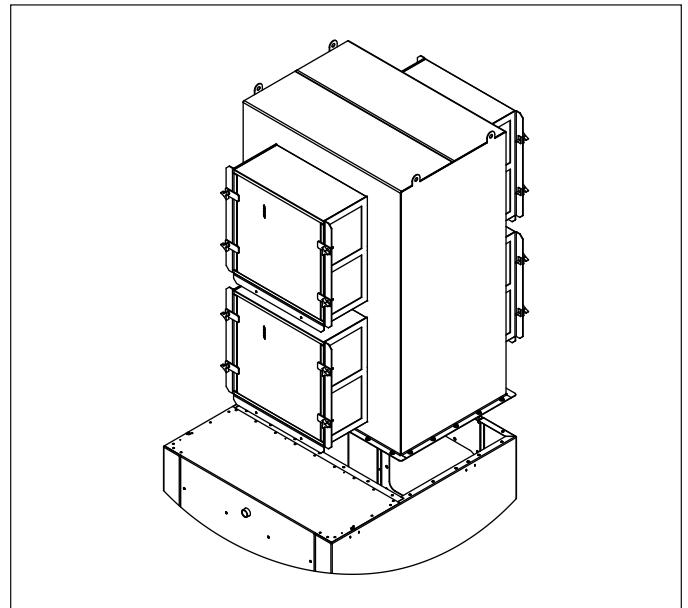

Optional AfterFilter Installation

Acoustic Curtain for Power Module

1. Install the acoustic curtain to the front of the power module by aligning the acoustic curtain holes with the non-louvre door holes and secure with nylon Christmas Tree™ clips.

Chamber Silencer



Turn power off and lock out electrical power sources before performing service or maintenance work.

NOTICE

Do not install in classified hazardous atmospheres without an enclosure rated for the application.

Install chamber silencer after the motors are wired and rotation checked.

Install the silencer to the top of the power module using the hardware and drawing supplied.

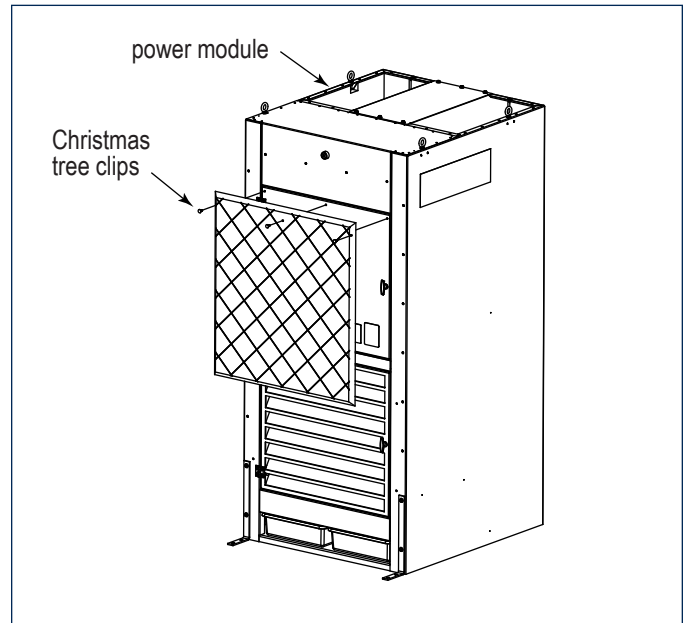

Acoustic Curtain Assembly

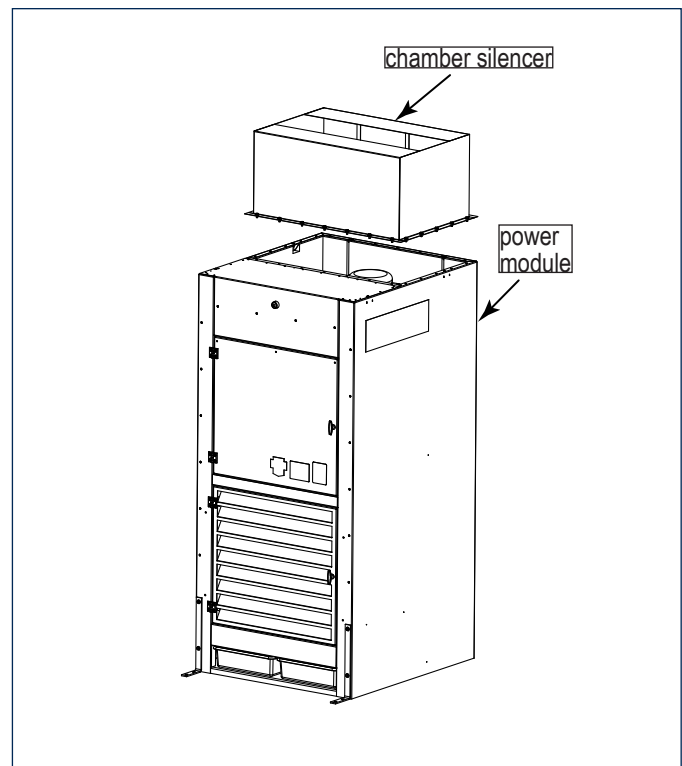

Chamber Silencer

IEC Control Panel with Programmable Logic Control



Electrical work must be performed by a qualified electrician and comply with all applicable national and local codes.

Turn power off and lock out electrical power sources before performing service or maintenance work.

Do not install in classified hazardous atmospheres without an enclosure rated for the application.

This control panel contains a safety disconnect switch, blower motor control, pulse control functions, and a Magnehelic gauge. The Programmable Logic Control, PLC, provides features such as sequential start-up, staggered aftershift cleaning, and troubleshooting capabilities.

Blower Control Functions

1. This control panel includes magnetic starters with a low-voltage control circuit.
2. The blower motor ON/OFF buttons are located on the control panel cover. A red blower motor RUNNING light is also provided.
3. Sequential start-up is provided for all DWS 4- and DWS 6- 2, 3, and 4 modules. This allows a delay between starting each blower motor and reduces undesirable overload current at start-up.
4. The control panel has troubleshooting capabilities. If a blower motor shuts down due to a failure, such as an overload, the panel will flash the red RUNNING light quickly. The two amber lights, CLEANING and AFTERSHIFT CLEANING, will also flash indicating which circuit tripped the alarm. For example: The overload on motor protector #3 is tripped. The red RUNNING light will flash quickly and the two amber lights, CLEANING and AFTERSHIFT CLEANING, will flash three times, then pause and repeat. This indicates that motor protector #3 has been tripped. The lights will continue to flash until the alarm is serviced.
5. Thermal overload relays and circuit breakers are provided for the motor circuit and fuses for the low voltage circuit. Standard voltages available are 208/230/460/575/60 Hz/3 phase.

Pulse Control Functions

1. Each power module has four or six 115-Volt AC solenoid valve enclosure that control four or six diaphragm valves, which clean the filter cartridges. The control panel PLC controls the solenoids.
2. The two-position switch on the front panel controls the HAND pulsing mode. When in the HAND mode, pulsing is continuous until the switch is turned to the OFF position or until the blowers are turned off. If hand pulsing is enabled more than once while the blowers are on, the last solenoid valve fired is remembered and the panel fires the next valve in sequence. Pulsing will be continuous while the DWS is running. This setting is suggested for high dust loading situations.
3. The aftershift cleaning function is designed to pulse for a designated period of time at the end of the work shift. In this mode, the noise associated with the pulsing of the filter cartridges can be avoided during work hours.
4. In conjunction with the aftershift pulsing function, a toggle switch located inside the control box turns the blower motors ON or OFF. When the aftershift push button is activated with the toggle switch in the STAG position, the even-numbered blowers shut off and the odd-numbered blowers remain on. All valves, starting with number one, are pulsed three times. The even-numbered blowers turn on and the odd-numbered blowers turn off. All valves are pulsed three times once more. The even-numbered blowers remain on for three minutes, when all blowers are shut down, and the system is deactivated.

Note: Route wiring through the conduit holes located in the rear of the power module. A conduit hole is also located in the blower panel above the solenoid valves. All conduit holes are sized for 3/4-in fittings. Secure all conduit in the blower plenum and in the solenoid plenum. Seal conduit to prevent air from passing through to the control panels.

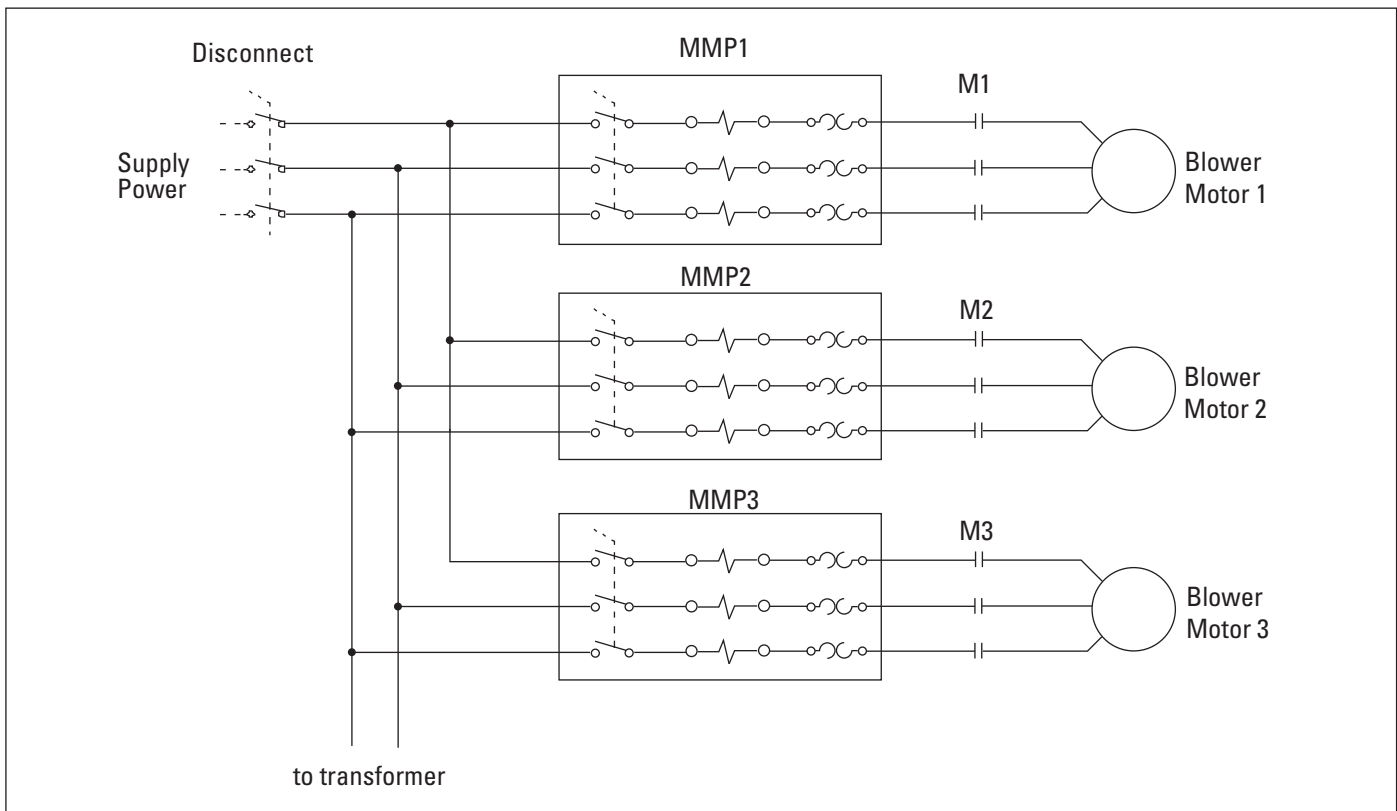

Optional IEC Control Panel Motor Wiring Diagram

When the aftershift button is activated in single power module collectors, the blower turns off and each valve pulses three times. The blower turns on, the valves pulse three more times, and both blower and pulsing turn off.

When the aftershift-cleaning button is pushed, the amber light illuminates and the pulse sequence is initiated. The pulse sequence continues until terminated by the aftershift-cleaning timer. This timer, located inside the control box, is factory set for a specified length of time depending upon how many power modules are used. The timer for a single power module is set at 3 minutes, two module at 6 minutes, three module at 9 minutes, and four module at 12 minutes. This allows each pair of filter cartridges to be pulse cleaned six times at the end of the shift. If experience indicates that more time is required to pulse clean the filter cartridges, the timer can be adjusted from the factory setpoint to a maximum of 100 hours.

IEC Control Panel Installation



Electrical work must be performed by a qualified electrician and comply with all applicable national and local codes.

Turn power off and lock out electrical power sources before performing service or maintenance work.

Do not install in classified hazardous atmospheres without an enclosure rated for the application.

1. Mount the control panel in a convenient, accessible location.
2. Connect tubing to the low pressure barbed fitting located on the control panel (as shown) to the barb fittings on the rear of the power module marked Low.
3. Wire the control panel to the motor and solenoid valves as shown in Optional IEC Control Panel Motor Wiring Diagram and Optional IEC Control Panel to Solenoid Valves Wiring Diagram.

Note: Access the solenoid valves and blower motor by removing the access covers at the rear of the power module. Replace cover when wiring is complete.

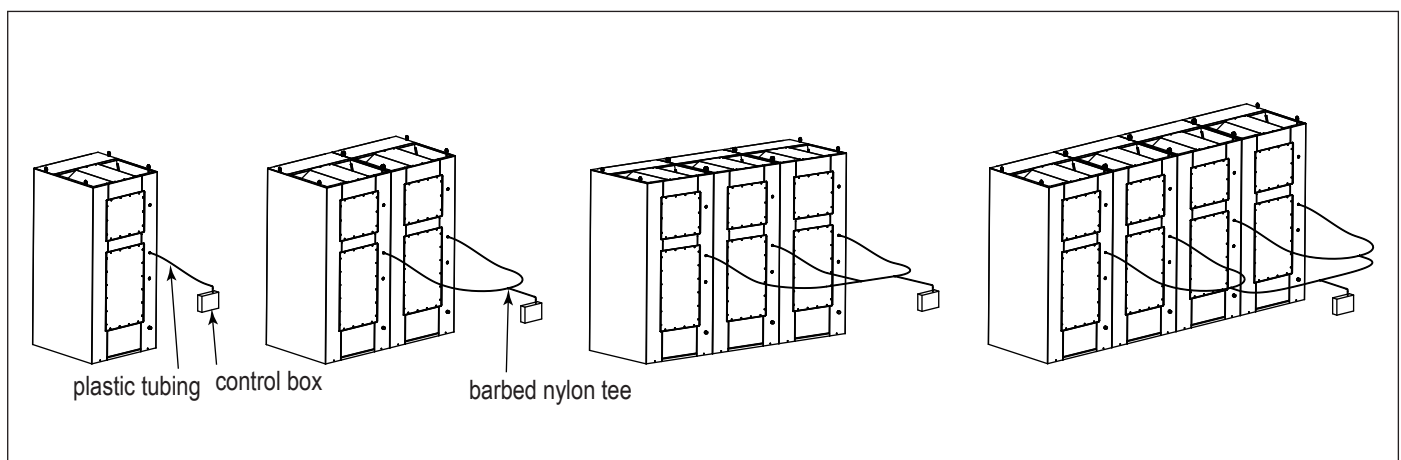

Control Box Tubing Connection

4. Turn the blower motor ON then OFF to check for proper rotation by referencing the rotation arrow located on the motor's mounting plate.

To reverse rotation, three-phase power supply: Turn electrical power OFF at source and switch any two leads on the output-side of the blower-motor starter.

5. Connect compressed-air supply following the instructions in Compressed Air Installation.
6. With power supply ON, check the operation of the solenoid valves by turning the switch on the front of the control panel in the HAND position and pressing the START button. The valves should open and close sequentially at factory set 10-second intervals.
7. Turn the switch OFF.

Sprinkler

NOTICE

Consult with local authorities when installing fire control systems on dust collection equipment.

Sprinkler couplings are provided for the convenience of fire control system installers. The fire control system installer shall make their own decisions on the appropriate location of fire control system components.

Start-Up/Commissioning Collector

Instruct all personnel on safe use and maintenance procedures.



Electrical work during installation, service or maintenance must be performed by a qualified electrician and comply with all applicable national and local codes.

Turn power off and lock out all power before performing service or maintenance work.

Turn compressed air supply OFF, bleed and lock out lines before performing service or maintenance work.

Check that the collector is clear and free of all debris before starting.

Do not install in classified hazardous atmospheres without an enclosure rated for the application.

Once the DWST has been placed, anchored and connected to electrical power, compressed air and connected to booth assembly if applicable, the collector is ready for initial start and commissioning.

1. Check all electrical connections for tightness and contact.
2. Check that fan wheel set screws are properly torqued (10.5 foot pounds for 3/8-in stainless steel set screws and 25 foot pounds for 1/2-in stainless steel set screws) prior to initial start-up.



Set screws on fan wheels must be properly tightened to avoid severe personal injury and/or property damage.

3. Check for proper rotation as noted on the fan housing.



Do not look into fan outlet to determine rotation. View the fan rotation through the back of the motor.

Check that the exhaust plenum is free of tools or debris before checking blower/fan rotation.

Stand clear of exhaust to avoid personal injury.

Do not interchange a power lead with the ground wire. Severe personal injury and/or property damage may result.

- a. "Bump" the fan to initiate rotation. Momentarily hit the ON button followed by the OFF button.
 - b. As the fan is winding down (unpowered) use a flashlight to visually observe the direction of fan rotation through the roof opening.
 - c. Compare fan rotation to the rotation label (located adjacent to the fan) direction.
4. If the fan rotation is reversed, correct the rotation.

To reverse rotation, single-phase power supply: Follow manufacturer's instructions on the motor's nameplate.

To reverse rotation, three-phase power supply: Switch any two leads on the motor junction box.

- a. Turn off the collector and Lock-Out all energy sources.
- b. Within the top mounted junction box, swap the connection location of two power leads on the terminal block, making certain not to swap a power lead and the ground wire.



Do not interchange a power lead with a ground wire or severe personal injury and/or property damage may result.

5. All access panels should be sealed and secure.
6. Check that the dust drawers are properly installed.
7. Check and remove all loose items in or near the inlet and outlet of the collector.
8. Check that all remote controls and solenoid enclosures (if applicable) are properly wired and all service switches are in the OFF position.
9. Check that all optional accessories are installed properly and secured.
10. Check that filters are secure by turning the filter knob clockwise. Turn by hand only. Do not use a wrench.
11. Turn power ON at source.
12. Turn the compressed-air supply ON. Adjust pressure regulator for 50-psig.
13. Turn blower fan motor ON.
14. If equipped, set the Photohelic gauge low setpoint to 2-in wg, the high setpoint to 4-in wg, and zero the indicator needle.
15. Once powered, verify the Delta P (or Delta P Plus) comes "on line" and shows a filter restriction of near zero on the digital display.
16. Using the Delta P (or Delta P Plus) Installation Manual as a guide, confirm the values of the Low, High, and Alarm set points. During normal operation the DWST will not begin to pulse clean until filter resistance reaches or exceeds the High set point.
17. Set the selector switch to the type of cleaning required.
Optional IEC Control Panel: HAND is continuous clean, OFF is aftershift cleaning.
Note: If aftershift cleaning is selected, set the toggle switch located inside the control panel to ON or STAG (staggered) and zero the Magnehelic® gauge needle.
18. Repeat steps 2-3 to confirm fan rotation.
19. Verify the dust drawers are pushed as far back in the collector as possible. Frequently check the dust bin level and empty as appropriate.
20. Log the date of initial operation and begin operation.
21. Verify display gauges are reading a positive value.

Decommissioning Collector

Once the collector has reached the end of operational life it will need to be decommissioned.



During decommissioning, there is potential for exposure to the dust in the collector. Most dusts present safety and health hazards that require precautions. Wear eye, respiratory, head and other protection equipment suitable for the type of dust when performing any decommissioning activities.

LOCK-OUT all energy sources prior to performing any decommissioning activities on the equipment.

Electrical service must be performed by a qualified electrician.

Disconnection of compressed air must be performed by a qualified pipe fitter.

Disconnection of ducts must be performed by a qualified tinsmith or contractor.

1. Turn off the collector and Lock-Out all energy sources.
2. Remove all filters from the collector and dispose of in a suitable fashion for the dust in the collector. (See Filter Replacement for instructions). Close and secure front access doors after filters are removed.
3. Remove and empty the dust drawers of any residual dust.
4. Disconnect compressed air supply from the collector and remove any associated pipe or fittings from the exterior of the collector.
5. Disconnect electrical power from the collector and remove any associated conduit or hardware from the exterior of the collector.
6. Seal the inlet and discharge openings of the collector with shipping covers to prevent residual dust from migrating from the collector during transport for disposal.
7. Remove anchor bolts and hardware from the collector.
8. Pick up the collector and place in a location suitable to prepare it for transportation. (See Lifting Information for lifting guidance.)
9. Secure the collector to a suitable transport carrier and transport to a disposal site suitable for the dust in the collector.

Product Information (Process Owner to complete and retain for your records)

Model Number _____	Serial Number _____
Ship Date _____	Installation Date _____
Filter Type _____	
Collected Dust _____	
Dust Properties: Kst _____	Pmax _____ MIE _____ MEC _____
Accessories _____	
Other _____	

Donaldson Industrial Air Filtration Warranty

Donaldson warrants to the original purchaser only that the Goods will be free from defects in material and manufacture for the applicable time periods stated below: (1) Major structural components for a period of ten (10) years from the date of shipment; (2) Non-Structural, Donaldson-built components and accessories including Donaldson Airlocks, TBI Fans, TRB Fans, Fume Collector products, Donaldson built electrical control components, and Donaldson-built Afterfilter housings for a period of twelve (12) months from date of shipment; and (3) Donaldson-built filter elements for a period of eighteen (18) months from date of shipment.

Buyer is solely responsible for determining if goods fit Buyer's particular purpose and are suitable for Buyer's process and application. Seller's statements, engineering and technical information, and recommendations are provided for the Buyer's convenience and the accuracy or completeness thereof is not warranted. If, after Seller receives written notice, within the warranty period, that any goods allegedly do not meet Seller's warranty, and Seller, in its sole discretion, determines that such claim is valid, Seller's sole obligation and Buyer's exclusive remedy for breach of the foregoing warranty or any Seller published warranty, will be, at Seller's option, either: (i) repair or replacement of such goods or (ii) credit or refund to Buyer for the purchase price from Seller. In the case of repair or replacement, Seller will be responsible for the cost of shipping the parts but not for labor to remove, repair, replace or reinstall the allegedly defective goods. Refurbished goods may be used to repair or replace the goods and the warranty on such repaired or replaced goods shall be the balance of the warranty remaining on the goods which were repaired or replaced. Any repair or rework made by anyone other than Seller is not permitted without prior written authorization by Seller, and voids the warranty set forth herein. Seller warrants to Buyer that it will perform services in accordance with the Sales Documents using personnel of required skill, experience and qualifications and in a professional and workmanlike manner in accordance with generally recognized industry standards for similar services. With respect to any services subject to a claim under the warranty set forth above, Seller shall, in its sole discretion, (i) repair or re-perform the applicable services or (ii) credit or refund the price of such services at the pro rata contract rate and such shall be Seller's sole obligation and the exclusive remedy for breach of the foregoing warranty on services. Products manufactured by a third party ("Third Party Product") may constitute, contain, be contained in, incorporated into, attached to or packaged together with, the goods. Buyer agrees that: (a) Third Party Products are excluded from Seller's warranty in this Section 7 and carry only the warranty extended by the original manufacturer, and (b) Seller's liability in all cases is limited to goods of Seller's design and manufacture only. EXCEPT FOR SELLER'S WARRANTY OF TITLE TO THE GOODS, SELLER EXPRESSLY DISCLAIMS AND EXCLUDES ALL OTHER WARRANTIES WHATSOEVER, WHETHER, EXPRESSED OR IMPLIED, ORAL, STATUTORY, OR OTHERWISE, INCLUDING BUT NOT LIMITED TO MERCHANTABILITY, FITNESS FOR A PARTICULAR PURPOSE, NON-INFRINGEMENT OF THIRD PARTY INTELLECTUAL PROPERTY AND ANY WARRANTIES ARISING FROM TECHNICAL ADVICE OR RECOMMENDATIONS, COURSE OF DEALING OR OF PERFORMANCE, CUSTOM OR USAGE OF TRADE. Seller's obligations do not cover normal wear and tear or deterioration, defects in or damage to any goods resulting from improper installation, accident or any utilization, maintenance, repair or modification of the goods, or any use that is inconsistent with Seller's instructions as to the storage, installation, commissioning or use of the goods or the designed capabilities of the goods or that, in its sole judgment, the performance or reliability thereof is adversely affected thereby, or which is subjected to abuse, mishandling, misuse or neglect or any damage caused by connections, interfacing or use in unforeseen or unintended environments or any other cause not the sole fault of Seller, and shall be at Buyer's expense. Seller's warranty is contingent upon the accuracy of all information provided by Buyer. Any changes to or inaccuracies in any information or data provided by Buyer voids this warranty. Seller does not warrant that the operation of the goods will be uninterrupted or error-free, that the functions of the goods will meet Buyer's or its customer's requirements unless specifically agreed to, or that the goods will operate in combination with other products selected by Buyer or Buyer's customer for its use.

The terms of this warranty may only be modified by a special warranty document signed by a Director, General Manager or Vice President of Donaldson. To ensure proper operational performance of your equipment, use only genuine Donaldson replacement parts.

This Product is provided subject to and conditioned upon Donaldson's Terms of Sale ("Terms"), a current copy of which is located at termsofsale.donaldson.com. These Terms are incorporated herein by reference. By purchasing or using this Product, the user accepts these Terms. The Terms are available on our website or by calling our customer service line at 1-800-365-1331.

Significantly improve the performance of your collector with genuine Donaldson Torit replacement filters and parts. **Call Donaldson Torit at 800-365-1331.**

Important Notice

Many factors beyond the control of Donaldson can affect the use and performance of Donaldson products in a particular application, including the conditions under which the product is used. Since these factors are uniquely within the user's knowledge and control, it is essential the user evaluate the products to determine whether the product is fit for the particular purpose and suitable for the user's application. All products, product specifications, availability and data are subject to change without notice, and may vary by region or country.



Donaldson.

Donaldson Company, Inc.
Minneapolis, MN
donaldsonorit.com • shop.donaldson.com

North America
Email: donaldsonorit@donaldson.com
Phone: (USA): 800-365-1331 • (MX): 800-343-3639

Australasia
Email: marketing.australia@donaldson.com
Phone: +61 2 4350 2000
Toll Free: (AU) 1800 345 837 • (NZ) 0800 743 387

IOM AG8550401 (ENG), Revision 0 (November 2019) ©2019 Donaldson Company, Inc. Donaldson, Torit, Downflo, Ultra-Web, Fibra-Web, Ultra-Tek, Thermo-Web, Torit-
Tex and the color blue are marks of Donaldson Company, Inc. All other marks belong to their respective owners.

China IAF
Email: info.cn@donaldson.com
Phone: (86) 400-820-1038

Donaldson Europe B.V.B.A.
Email: IAF-europe@donaldson.com
Phone: + 32 (0) 16 38 38 11

India
Email: marketing.India@donaldson.com
Phone: +91 124 4807400
Toll Free: 18001035018

Latinoamerica
Email: IndustrialAir@donaldson.com
Phone: +52 449 300 2442

South Africa
Email: SAMarketing@donaldson.com
Phone: +27 11 997 6000

Southeast Asia IAF
Email: IAF.SEA@donaldson.com
Phone: (65) 63117373