



Downflo® Evolution

DFE 2-8, 2-12, 3-12, 3-18, 3-24, 3-36, 3-48, 3-60, 3-72, 4-16, 4-24, 4-32, 4-48, 4-64, 4-80, 5-20, 5-30, 5-40, 5-60 and 5-80

Installation and Operation Manual

Installation, Operation, and Service Information

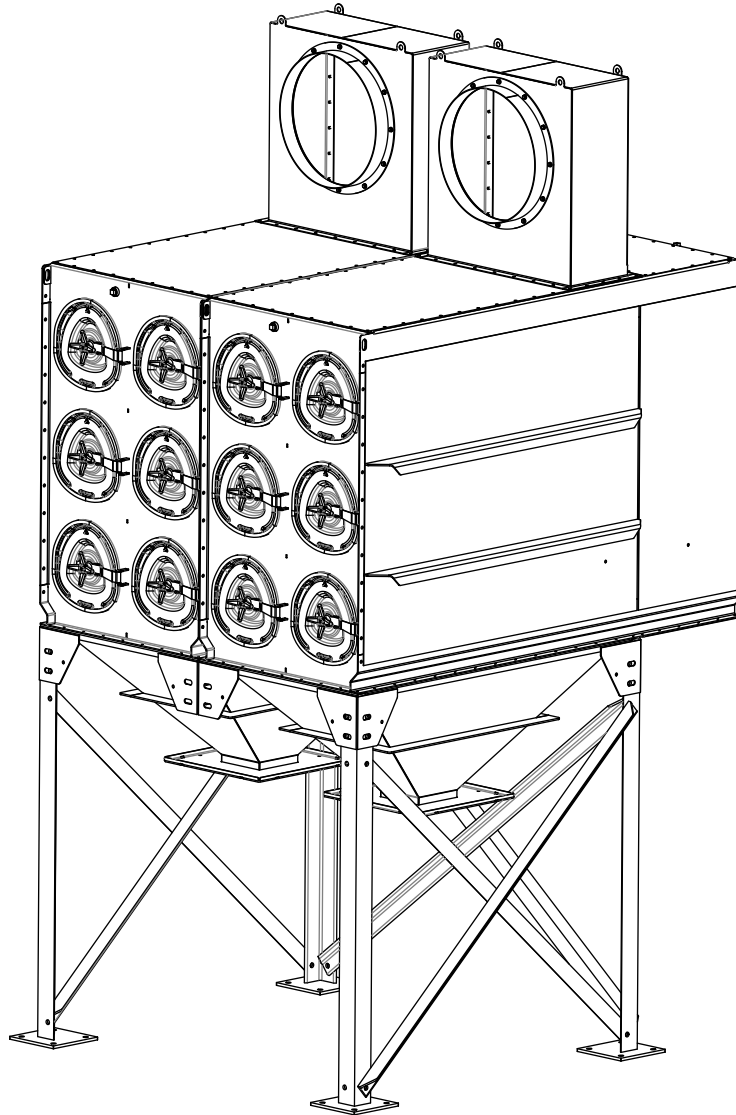

This manual contains specific precautions related to worker safety. The hazard alert image denotes safety related instructions and warnings in this manual. DO NOT install, operate, or perform maintenance on this collector until you have read and understood the instructions, precautions and warnings contained within this manual.

IMPORTANT NOTES

This manual has been supplied to assist with the installation, operation and maintenance for the collector purchased. Please read the manual before installing, operating, or performing maintenance on the collector as it contains specific precautions for worker safety. It is the owner's responsibility to ensure that this manual is available for use by installers, operators and maintenance personnel that will be working with this collector. This manual is the property of the owner and should be left with the collector when installation has been completed. **DO NOT** operate this collector until you have read and understood the instructions and warnings located in this manual.

For additional copies of this manual, contact Donaldson Torit.



The Safety Alert Symbol indicates a hazardous situation which, if not avoided could result in death or serious injury. Obey all safety messages following this symbol to avoid possible injury or death. The possible hazards are explained in the associated text messages.

NOTICE

NOTICE indicates a potential situation or practice which is not expected to result in personal injury, but which if not avoided, may result in damage to equipment.

Contents

| | |
|--|----|
| IMPORTANT NOTES | i |
| 1 Safety Communication | 1 |
| 2 Product Description | 3 |
| 3 Operation | 6 |
| 4 Product Service | 7 |
| Dust Disposal | 8 |
| Filter Replacement | 8 |
| Compressed Air Components | 9 |
| Troubleshooting | 11 |
| Appendix A - Installation | 14 |
| Standard Equipment | 18 |
| Hopper Installation | 18 |
| Leg Installation | 18 |
| Platform and Ladder Installation | 19 |
| Module Assembly | 21 |
| Yoke, Venturi and Filter Installation | 23 |
| Compressed Air Installation | 25 |
| Electrical Wiring | 25 |
| Solid-State Timer Installation | 27 |
| iCue Gateway Installation | 29 |
| Options and Accessories | 33 |
| Fan Controls | 33 |
| TBI and TRB Style Damper and Silencer Support Bracket | 34 |
| Cleaning Controls and Sensors | 35 |
| Magnehelic® Gauge | 35 |
| Photohelic® Gauge | 36 |
| Delta P Control | 38 |
| Delta P Plus Control | 38 |
| Hopper Discharge Accessories | 39 |
| Hopper Bag-Out Replacement | 42 |
| Inlet and Hi Flo Inlet Plenum | 43 |
| Extended Dirty-Air Plenum | 44 |
| Air Management Module | 44 |
| Cold Climate Kit | 45 |
| Explosion Relief Panel | 46 |
| Sprinkler Coupling | 46 |
| Start-up / Commissioning | 47 |
| Decommissioning | 48 |
| Appendix B - Clean Change Bag-In/Bag-Out Filter and Liner System | 49 |
| Product Information | 61 |
| Service Notes | 62 |
| Donaldson Industrial Air Filtration Warranty | 64 |

1 Safety Communication



Improper operation of dust collectors and/or dust control systems may contribute to conditions in a work area or facility which could result in severe personal injury, and product or property damage. All dust collection equipment should be used only for its intended purpose and should be properly selected and sized for its intended use.

Process owners have important responsibilities relating to identifying and addressing potential hazards in their processes. When the potential for handling combustible dust exists within a process the process owner should include combustion hazards in their risk management activities and should comply with applicable codes and standards related to combustible dust.

Electrical installation must be performed by a qualified electrician.

This equipment is not designed to support site ducts, piping, or electrical services. All ducts, piping, or electrical services must be adequately supported to prevent injury and/or property damage.

Site selection must account for wind, seismic zone, and other load conditions.

Equipment may reach peak sound pressure levels above 80 dB (A). Noise levels should be considered when selecting collector location.

Most dusts present safety and health hazards that require precautions. Wear eye, respiratory, head and other protection equipment suitable for the type of dust.

Some components may be heavier than they appear. Use appropriate lifting methods to avoid personal injury and/or property damage.

Combustible Dust Hazards

Among other considerations, the current NFPA standards require owners whose processes involve potentially combustible materials to have a current Dust Hazard Analysis, which can serve as the foundation for their process hazard mitigation strategy. Mitigation may include but is not limited to:

- Prevention of all ignition sources from entering any dust collection equipment.
- Selection and implementation of fire and explosion mitigation, suppression, and isolation strategies appropriate for the risks in their process.
- Development and use of work practices to maintain safe operating conditions, and to ensure combustible dust does not accumulate within their plant or process equipment.

Donaldson designs, manufactures, and sells industrial air filtration products for a wide variety of applications. Some applications may include processes or materials with inherent fire and explosion hazards. Donaldson is neither an expert nor a certified consultant in fire, spark, or explosion detection, suppression, or control. Donaldson does not provide engineering consulting services related to process or dust hazard analyses, or code and standard compliance. Complying with applicable codes and standards and managing the risks associated with the process or materials remains the responsibility of the process owner/operator. Donaldson may provide referrals to consultants, suppliers of equipment or services related to the detection and/or mitigation of sparks, fires and/or explosions, but Donaldson does not assume responsibility for any such referrals, nor does Donaldson assume any liability for the fitness of a mitigation strategy or product for a particular installation or application. The process owner's final selection of dust collectors and risk mitigation strategies should be based on the outcome of a Dust Hazard / Process Hazard Analysis performed by the process owner. Although early engagement of a dust collector supplier provides helpful insights on the availability and features of various products, process owners should consult with a combustible dust expert and/or a process safety expert before making actual product and mitigation strategy selections.

Donaldson recommends that all industrial air filtration system designs be reviewed and approved by an expert consultant who is responsible for the integrity of the system design and compliance with applicable codes and standards. It is the process owner's responsibility to understand the risks in their process and mitigate those risks in accordance with all applicable laws, regulations and standards, including those published by the NFPA. Donaldson also recommends that proper maintenance and housekeeping procedures and work practices be evaluated, developed, and followed to maintain any industrial air filtration products in safe operating condition.

Many factors beyond the control of Donaldson can affect the use and performance of Donaldson products in a particular application, including the conditions under which the product is used. Since these factors are uniquely within the user's knowledge and control, it is essential the user evaluate the Donaldson products to determine whether the product is fit for the particular purpose and suitable for the user's application. All products, product specifications, and data (airflow, capacity, dimensions, or availability) are subject to change without notice, and may vary by region or country.

2 Product Description

The Downflo® Evolution dust collector is a continuous-duty, modular collector with cartridge-style filters. The downward airflow design delivers high filtration efficiency while using less energy. Continuous duty means the filters can be pulse cleaned on-line without interrupting airflow through the collector. The filters are pulse-cleaned in sequence, one set at a time, without turning the collector off. Each standard collector is two or three filter columns wide by two, three, four, or five filter rows high by two filters deep.

Designed to increase the versatility of the collector, standard options include abrasion-resistant inlets, extended dirty-air plenums, air management modules and clean change options.

Intended Use

Downflo Evolution collectors are intended for filtration of nuisance dust where the dust loading to the collector is less than five grains per cubic foot. Some typical applications include metal grinding, plasma cutting, dry bulk, pharmaceutical, thermal spray, welding, metal manufacturing, glass, and food processing. Each application is different and selecting the correct filter for the application and dust being collected is important. Contact Donaldson Torit for selection assistance. •

- Fibrous dusts often benefit from a filter with an open-pleat design, such as Fibra-Web®.
- Operations involving high temperature and high humidity may require special attention. Temperature, moisture content, and chemistry issues may also require custom collector design.
- Hygroscopic dust such as fertilizer, salt, and sugar should be handled under a controlled, low humidity environment.
- Combustible dust may require customized collector design options.
- Applications with high hydrocarbon or high oil content may require special treatment or filter media.

Rating and Specification Information

General rating and specification information can be found in the product literature provided with the collector and is available on the Donaldson website. For specific load values for a collector, see the Specification Control Drawing shipped with the collector.

Standard Equipment

Standard Downflo Evolution collectors consist of collector module, inlet box, hopper, and legs. The legs and hopper are assembled first and the collector is placed in position using a crane or forklift.

Solenoid Enclosure

The collector is equipped with electric solenoid valves (typically 120V) that control the pulse-cleaning valves, which in turn release compressed air from the manifold to clean the filters. Solenoid enclosures are mounted near or on the collector's compressed-air manifold.

iCue Gateway

The iCue Gateway captures data from sensors and transmits the data wirelessly to the iCue application. The iCue Gateway has internal sensors for sensing filter differential pressure, airflow data and compressed air pressure of the cleaning manifold. The platform utilizes a gateway that captures data from sensors and transmits it wirelessly via a cellular connection to the web-based Donaldson iCue application. This platform operates independently of the dust collector control system. The iCue Gateway may be mounted to the rear of the collector or in a common enclosure with cleaning controls. Power to the iCue Gateway is supplied by the customer.

Sprinkler Coupling

Sprinkler couplings are provided for the convenience of fire control system installers. The fire control system installer shall make their own decisions on the appropriate location of fire control system components.

Options and Accessories

Fan Controls

The collector can accept a direct mounted fan, Torit Backward Inclined (TBI) or Torit Radial Blade (TRB), to the side or top of the collector. An adapter allows a TBI fan to be mounted directly to the top or side of the collector. Field assembly of the adapter is required.

Cleaning Controls and Sensors

Differential Pressure Gauge

A Magnehelic®, Photohelic®, or equivalent differential pressure gauge is used to measure the pressure difference between the clean-air and dirty-air plenums and provides a visual display of filter condition. The high-pressure tap is located in the dirty-air plenum and the low-pressure tap is located in the clean-air plenum.

Delta P Control

The Delta P Controller monitors the differential pressure between the clean-air and dirty-air plenums, providing a visual display of the filter condition. When combined with a pulse timer, it manages the pressure drop by turning the cleaning mechanism On and Off at the chosen limits. There are three (3) set points: HIGH (On), LOW (Off) and ALARM. The first two, HIGH (On) and LOW (Off) control the filter cleaning system. The third, ALARM, provides a relay output to activate an external alarm supplied by others.

Delta P Plus Control

The Delta P Plus Controller monitors the differential pressure between the clean-air and dirty-air plenums, providing a visual display of the filter condition. When combined with a pulse timer, it manages the pressure drop by turning the cleaning mechanism On and Off at the chosen limits. There are three (3) set points: HIGH (On), LOW (Off) and ALARM. The first two, HIGH (On) and LOW (Off), control the filter cleaning system. The third, ALARM, provides a relay output to activate an external alarm supplied by others.

The user can program the Delta P Plus Controller to pulse while the collector is running, to maintain a relatively constant pressure drop across the filters, pulse only after the collector is shut down (after-shift cleaning), or a combination of both, cleaning while running as well as end of the shift.

Hopper Discharge Accessories

Hopper Outlet

The hopper outlet is located at the base of the hopper where separated dust can exit the collector. A bin, rotary airlock, screw conveyor, or other means of sealing the hopper outlet is required to prevent air intrusion into the hopper. The hopper discharge device may also need to isolate the hopper outlet during a deflagration.

55-Gallon Drum Pack

The drum pack is designed to fit a customer-supplied, standard 55-gallon drum and provides easy access for dust removal and disposal. A flexible hose connects the drum cover to the hopper. Placing a pallet under the drum allows heavier materials to be moved quickly using a forklift or pallet jack. If a pallet is used, the length of flexible hose may need to be shortened.

Platform and Ladder

Collector may be equipped with a platform and ladder system for gaining access to the clean air plenum for filter changeout. For all ladders over 24-ft OSHA requires a ladder safety system or personal fall arrest system. As a convenience, Donaldson offers ladder safety systems as an option.

Inlet Plenum

The inlet plenum is standard on Downflo Evolution collectors unless another inlet plenum option has been selected. The inlet plenum directs the dirty air stream to the back of the dirty-air plenum over the venturi section.

High Flo Inlet Plenum

The high flo inlet plenum is used in applications with higher flow rates. The high flo inlet plenum is supplied with standard service access panels on the front, back and top of the plenum. The top access panel is available with and without an explosion vent.

Extended Dirty-Air Plenum

The extended dirty-air plenum is used in applications requiring an air management module or when a single inlet serves multiple modules.

The extended dirty-air plenum is supplied with standard service access panels on the sides and top of the plenum.

The top access panel is available with and without an explosion vent.

Air Management Module

The air management module is used in applications involving heavy grain loading, large or abrasive particles in the airstream, or in applications when a collector with a single inlet serves multiple modules. It is equipped with a louvered panel near the bottom, which prevents re-entrainment of the dust that falls through to the hopper. This module does not contain filters, and is available for use with an extended dirty-air plenum only.

Air management modules are supplied with a standard 36 x 24-in and 36 x 16-in covered opening on front of the collector.

Cold Climate Kit

A cold climate kit provides heat to the pulse valves to prevent cold weather freeze up. The basic kit, for use in applications that have a moderate amount of moisture in the compressed-air supply, consists of a small heating element and thermostat installed in the solenoid enclosure. The basic kit is factory-installed and supplied with the appropriate solenoid wiring instructions.

A heavy-duty kit is available for applications that have moderate-to-high amounts of moisture in the compressed-air supply and consists of the basic kit plus a heat cable to deliver heat to the large pulse valves. This kit is customer-installed and detailed installation instructions are provided.

Explosion Relief Panels

Collector may be equipped with optional explosion relief panels to support a process owners combustible dust mitigation strategy. Explosion vent sizing follows NFPA-68 formulas assuming outdoor location of collector with no duct or obstruction on the explosion vent panels. Contact Donaldson Torit for explosion venting requirements for other conditions.

3 Operation



Electrical work during installation, service or maintenance must be performed by a qualified electrician and comply with all applicable national and local codes.

Turn all power off and lock out all power before performing service or maintenance work.

Turn compressed air supply off, bleed and lock out lines before performing service or maintenance work.

Check that the collector is clear and free of all debris before starting.

Do not install in classified hazardous atmospheres without an enclosure rated for the application.

During normal operation, dust-laden air enters the collector through the dirty-air inlet, which is positioned over the venturi section of the dirty air plenum. Airflow is directed downward through the collector over the venturis and heavier particulate falls directly into the hopper. The filters remove fine particulate allowing filtered air to pass through the filters to the clean-air plenum where it discharges through the clean-air outlet.

Filter cleaning is completed using pulse-jet technology. A solenoid and diaphragm valve aligned to each row of filters provides the pulse cleaning. The cleaning sequence starts at the top filter row and continues down through the module. Removal, inspection, or replacement of filters can be accomplished from outside the collector by removing the filter access cover and sliding the filters out.

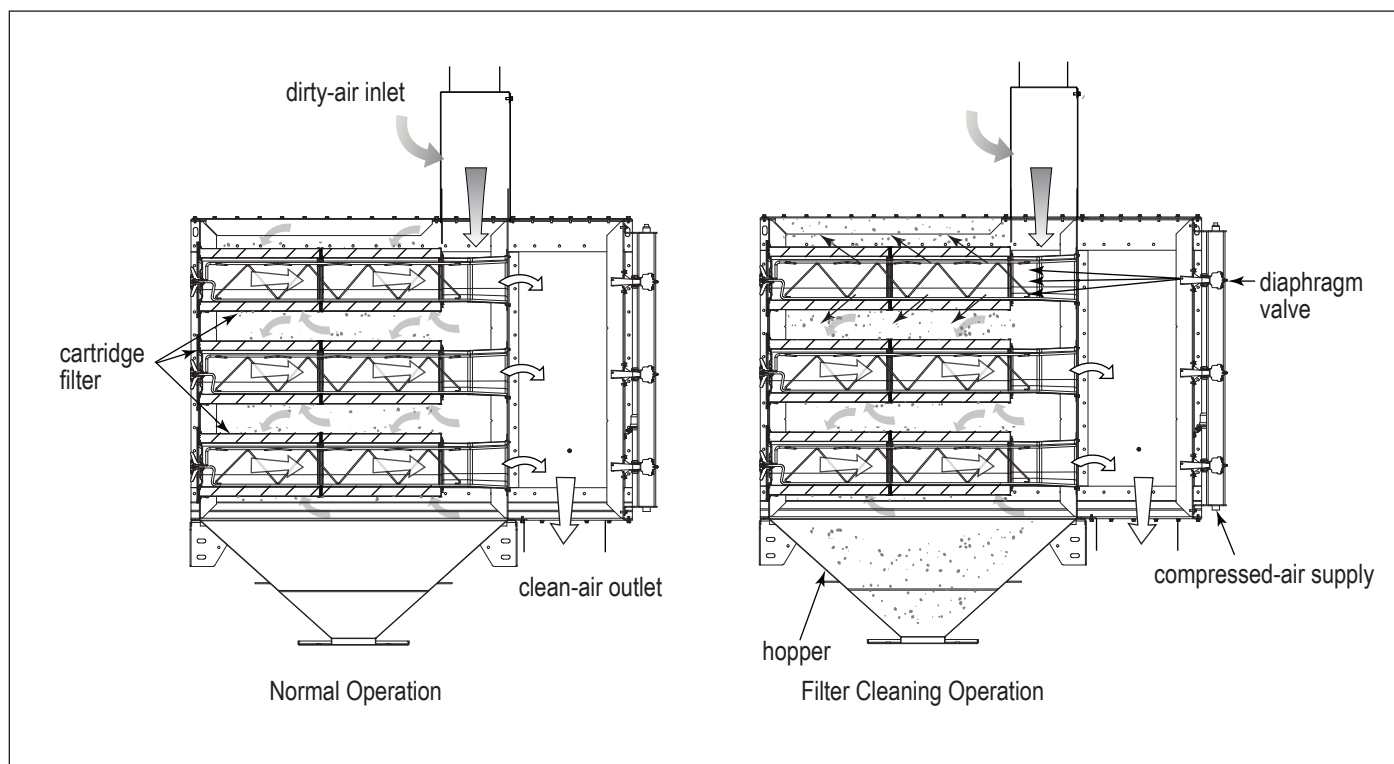

Collector Operation

4 Product Service



During service activities there is some potential for exposure to the dust in the collector. Most dusts present safety and health hazards that require precautions. Wear eye, respiratory, head and other protection equipment suitable for the type of dust when performing any service activities.

Use appropriate access equipment and procedures. Note the standard collector is not equipped with access platforms unless noted on the specification drawings.

LOCK-OUT all energy sources prior to performing any service or maintenance on the equipment.

Electrical service or maintenance work must be performed by a qualified electrician and comply with all applicable national and local codes.

Turn compressed air supply OFF, bleed and lock out lines before performing service or maintenance work.

NOTICE

Do not set compressed-air pressure above 100-psig as component damage can occur.

All compressed air components must be sized to meet the system requirements of supply pressure.

The compressed-air supply must be oil and moisture free. Contamination in the compressed air used to clean filters will result in poor cleaning, cleaning valve failure, or poor collector performance.

Purge compressed air lines to remove debris before connecting to the collector's compressed air manifold.

Operational Checklist

1. Monitor the physical condition of the collector and repair or replace any damaged components.

Routine inspections will minimize downtime and maintain optimum system performance. This is particularly important on continuous-duty applications.

2. Periodically check the compressed air components and replace compressed air filters.

Drain moisture following the manufacturer's instructions. With the compressed air supply ON, check the cleaning valves, solenoid valves, and tubing for leaks. Replace as necessary.

3. Monitor pressure drop across filters.

Abnormal changes in pressure drop may indicate a change in operating conditions and possibly a fault to be corrected. For example, prolonged lack of compressed air will cause an excess build-up of dust on the filters resulting in increased pressure drop. Cleaning off-line with no airflow usually restores the filters to normal pressure drop.

4. Monitor exhaust.
5. Monitor dust disposal.

Dust Disposal

1. Shut the collector OFF prior to emptying the dust container (bin, pail, or drum).
2. Transfer dust from the dust container to a suitable disposal site and dispose of dust in accordance with local requirements for the materials being collected.
3. Empty when dust container is 2/3 full. Check integrity of gasket under container cover. Replace gasket if worn or damaged.
4. If optional slide gate is used, close gate before servicing the dust container.



Sharp edge of slide gate may result in personal injury while closing the slide gate. Keep hands clear when operating the slide gate.

5. Replace or reinstall dust container, reclamp to the collector and open slide gate (if applicable).

NOTICE

To avoid possible damage to the fan motor, maintain a seal below the collector if servicing the dust storage device while the fan is running.

6. The collector can now be returned to service.

Filter Replacement



Most dusts present safety and health hazards that require precautions. Wear eye, respiratory, head and other protection equipment suitable for the type of dust.

Use proper safety and protective equipment when removing contaminants and filters.

Dirty filters may be heavier than they appear. Use appropriate equipment to access filters and appropriate lifting methods to avoid personal injury and/ or property damage.

Turn all power OFF and lock out all power before performing service or maintenance work.

Turn compressed air supply OFF, bleed and lock out lines before performing service or maintenance work.

Do not operate with missing or damaged filters.

NOTICE

Reference Appendix B for Clean Change Bag-In/Bag-Out Filter and Liner System information.

1. Turn all power to the collector OFF.
2. Begin filter replacement with the top row of filters. Select a filter access port and remove access cover by turning knob counterclockwise.
3. Break the seal between the filter cartridge and the sealing surface.
4. Slide each filter out the access port along the suspension yoke and dispose of in accordance with local requirements for the materials being collected.
5. Proceed to the next row of filters and repeat for all remaining filters.
6. Inspect and clean the sealing surface if necessary.

NOTICE

Clean dust from gasket sealing area to ensure a positive filter gasket seal.

7. Clean any dust from the yoke threads that may have accumulated during the filter removal.

8. Check for any accumulation of dust in the storage area and remove as necessary.
9. Slide the gasket end of each new filter onto the end of the suspension yoke.

NOTICE

The filter shape and yoke work together to ensure proper filter alignment during filter installation. To assist with alignment, an alignment mark (\triangle) at the top of the filter endcap (non-gasketed end) must match with the alignment mark (∇) at the top of the filter access opening.

10. Proceed to the next row of filters and repeat for all remaining filters.
11. Inspect cover gaskets. Clean and/or replace as necessary.
12. After new filters have been installed, place the access cover on the yoke and hold it in position while tightening the knob securely by hand (3 turns) before using tool assist option.

NOTICE

The access cover must be properly aligned to ensure a dust tight seal to the housing.

Do not exceed 150 in-lbs (12.5 ft-lbs) torque when securing the access cover as over tightening may cause damage to the filter and/or equipment.

When filter installation is complete, check to ensure that each access cover is seated and sealed against the filter housing to ensure a dust tight housing seal.

13. The collector can now be returned to service.

Compressed Air Components

1. Periodically check the compressed air components and replace damaged or worn components as necessary.
2. Drain moisture following the manufacturer's instructions.
3. With the compressed-air supply ON, check the cleaning valves, solenoid valves, and tubing for leaks. Repair or replace as necessary.

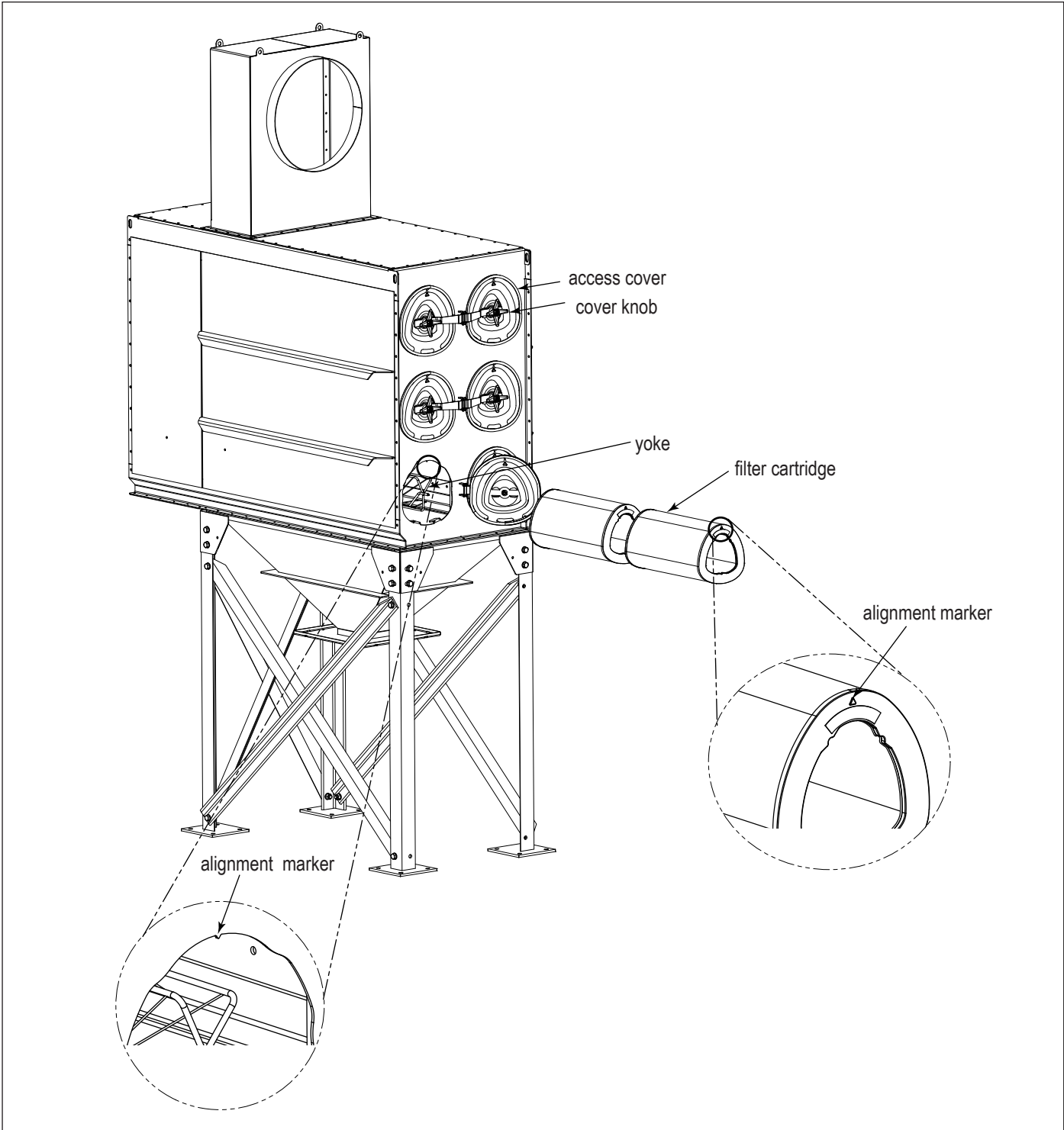

Filter Replacement

Troubleshooting

| Problem | Probable Cause | Remedy |
|--|---|---|
| Fan blower and motor do not start | Improper motor wire size | Rewire using the correct wire gauge as specified by national and local codes. |
| | Not wired correctly | Check and correct motor wiring for supply voltage. See motor manufacturer's wiring diagram. Follow wiring diagram and the National Electric Code. |
| | Collector not wired for available voltage | Correct wiring for proper supply voltage. |
| | Input circuit down | Check power supply to motor circuit on all leads. |
| | Electrical supply circuit down | Check power supply circuit for proper voltage. Check for fuse or circuit breaker fault. Replace as necessary. |
| | Damaged motor | Replace damaged motor. |
| Fan blower and motor start, but do not stay running | Incorrect motor starter installed | Check for proper motor starter and replace if necessary. |
| | Access doors are open or not closed tight | Close and tighten access doors. See Filter Replacement. |
| | Hopper discharge open | Check that dust container is installed and properly sealed. |
| | Damper control not adjusted properly | Check airflow in duct. Adjust damper control until proper airflow is achieved and the blower motor's amp draw is within the manufacturer's rated amps. |
| | Electrical circuit overload | Check that the power supply circuit has sufficient power to run all equipment. |
| Clean-air outlet discharging dust | Filters not installed correctly | See Filter Replacement. |
| | Filter(s) damaged or worn | Replace filters as necessary. Use only genuine Donaldson replacement parts. See Filter Replacement. |
| | Access cover(s) loose | Tighten access doors securely. See Filter Replacement. |
| Insufficient airflow | Fan rotation backwards | Proper fan rotation is clockwise when viewed from the motor side or counterclockwise when viewed through the inlet cone. See Start-Up/Commissioning. |
| | Access doors open or not closed tight | Check that all access doors are in place and secured. Check that the hopper discharge opening is sealed and that dust container is installed correctly. |
| | Fan exhaust area restricted | Check fan exhaust area for obstructions. Remove material or debris. Adjust damper flow control. |
| | Filters need replacement | Remove and replace using genuine Donaldson replacement filters. See Filter Replacement. |

| Problem | Probable Cause | Remedy |
|--|---|---|
| Insufficient airflow continued | Lack of compressed air | See the Specification Control Drawing shipped with the collector for compressed air supply requirements. |
| | Pulse cleaning not energized | Use a voltmeter to check the solenoid valves in the control panel. Check pneumatic lines for kinks or obstructions. |
| | Dust storage area overfilled or plugged | Clean out dust storage area. See Dust Disposal. |
| | Pulse valves leaking compressed air | Lock out all electrical power to the collector and bleed the compressed air supply. Check for debris, valve wear, pneumatic tubing fault, or diaphragm failure by removing the diaphragm cover on the pulse valves. Check for solenoid leaks or damage. If pulse valves or solenoid valves and tubing are damaged, replace. |
| | Solid-State timer failure | Using a voltmeter, check supply voltage to the timer board. Check and replace the fuse on the timer board if necessary. If the fuse is good and input power is present but output voltage to the solenoid is not, replace the timer board. See Solid-State Timer Installation. |
| | Solid-State timer out of adjustment | See Solid-State Timer and Solid-State Timer Typical Wiring Diagram. |
| No display on the Delta P Controller | No power to the controller | Use a voltmeter to check for supply voltage. |
| | Fuse blown | Check the fuse in the control panel. See wiring diagram inside the control panel. Replace if necessary. |
| Display on Delta P Controller does not read zero when at rest | Out of calibration | Recalibrate as described in Delta P Maintenance Manual. |
| | With collector discharging outside, differential pressure is present from indoor to outdoor | Recalibrate with the pressure tubing attached as described in the Delta P Maintenance Manual. |
| Delta P Controller ON, but cleaning system does not start | Pressure tubing disconnected, ruptured, or plugged | Check tubing for kinks, breaks, contamination, or loose connections. |
| | Not wired to the timing board correctly | Connect the pressure switch on the timer board to Terminals 7 and 8 on TB3. |
| | Faulty relay | Using a multimeter, test relay for proper closure. Replace if necessary. |

Troubleshooting

| Problem | Probable Cause | Remedy |
|--|--|--|
| Pulse cleaning never stops | Pressure switch not wired to the timer board correctly | Connect the pressure switch on the timer board to Terminals 7 and 8 on TB3. |
| | Pressure switch terminals on the timer board jumpered | Remove jumper wire on Solid-State Timer board before wiring to the Delta P Control. |
| | High Pressure On or Low Pressure Off setpoint not adjusted for system conditions | Adjust setpoints to current conditions. |
| | Pressure tubing disconnected, ruptured, plugged, or kinked | Check tubing for kinks, breaks, contamination, or loose connections. |
| Alarm light is ON | Alarm setpoint too low | Adjust to a higher value. |
| | Excess pressure drop | Check cleaning system and compressed air supply. Replace filters if filters do not clean down. |
| | Pressure tubing disconnected, ruptured, plugged, or kinked | Check tubing for kinks, breaks, contamination, or loose connections. |
| Delta P arrow keys do not work | Improper operation | Press and hold one of the three setpoint keys to use arrow keys. |
| | Programming keys disabled | Remove the Program Disable jumper from Terminals 3 and 4 on TB2. |
| Cleaning light is ON, but cleaning system not functioning | Improper wiring | Check wiring between the Delta P Control and the timer board, and between the timer board and solenoid valve coils. |
| | Defective solenoids | Check all solenoid coils for proper operation. |
| | Timer board not powered | Check power ON light on timer board's LED display. If not illuminated, check the supply voltage to the timer board. Check the fuse on the timer board. Replace if necessary. |
| | Timer board defective | If LED is illuminated, observe the output display. Install a temporary jumper across the pressure switch terminals. Output levels should flash in sequence. Check output using a multimeter set to 150-Volt AC range. Measure from SOL COM to a solenoid output. The needle will deflect when LED flashes for that output if voltage is present. If LED's do not flash, or if no voltage is present at output terminals during flash, replace the board. |

Appendix A - Installation

Installation



Electrical Installation (including bonding and grounding of the collector) must be performed by a qualified electrician.

This equipment is not designed to support site ducts, piping, or electrical services. All ducts, piping, or electrical services must be adequately supported to prevent injury and/or property damage.

Do not install in classified hazardous atmospheres without an enclosure rated for the application.

Service must be performed by trained and qualified maintenance personnel.

Turn all power off and lock out all power before performing service or maintenance work. It is not unusual for the equipment to be operated from a remote location, so equipment may start or stop unexpectedly.

Equipment may reach peak sound pressure levels above 80 dB (A). Noise levels should be considered when selecting equipment location.

Location and Site Selection



Codes may regulate recirculating filtered air in your facility. Consult with the appropriate authorities having jurisdiction to ensure compliance with all national and local codes regarding recirculating filtered air.

Equipment location must conform to all codes and standards, should be suitable for the type of dust being handled and should ensure easy access for service and utility connections. Site selection must account for wind, seismic zone and other load conditions.

The equipment must be anchored once in final position. Anchors must comply with local code requirements. Anchors, foundation or support framing must be capable of supporting dead, live, wind, seismic, and other applicable loads. Consult a qualified engineer for final selection of foundation or support framing.

Note: Ensure the inlet has at least five diameters of straight duct prior to the collector inlet including a transition to the full inlet dimensions. Inlet transition should have a taper with a maximum of a 90-degree included angle.

Follow industry practice relative to clean air velocity into a fan.

Provisional Anchor Bolt Recommendations

The quantity of anchor bolts should match the number of holes provided in the base plates of the collector. Anchor diameter is typically 1/8-inch less than the baseplate hole diameter. Anchors should project a minimum of 1 3/4 -inch and account for nut, washer, baseplate, and shims/grout.

Delivery and Inspection

Upon arrival inspect equipment and report any damage to delivery carrier. File any damage claims with the delivery carrier. Request a written inspection report from the Claims Inspector to substantiate all damage claims.

Compare the equipment received with the description of product ordered. Report any incomplete shipments to the delivery carrier and your Donaldson Torit representative.

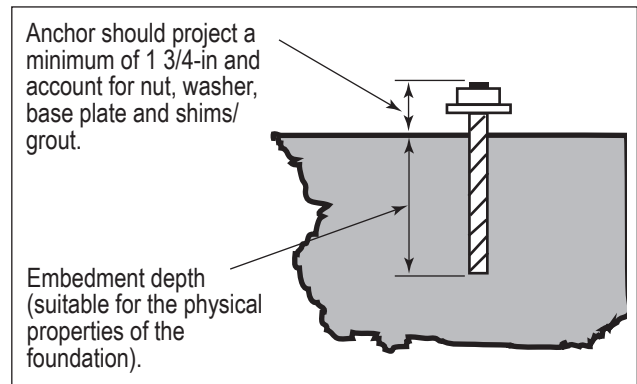

Typical Foundation Anchor

Unloading and Positioning



Equipment should be lifted only by qualified crane or fork truck operators.

Failure to lift the equipment correctly can result in severe personal injury and/or property damage.

1. Remove any crates or shipping straps.
2. Lift the packaged collector from transport container.
3. Inspect for any damage and/or missing parts and report to freight carrier.
4. Check for any hardware which may have become loose during shipment and tighten as necessary.

Lifting Information



Failure to lift the equipment or sub-assemblies correctly can result in severe personal injury and/or property damage.

Only qualified crane or forklift operators should be allowed to lift equipment.

1. Use all lifting points provided.
2. Use clevis connectors, not hooks, on lifting slings.
3. Use spreader bars to prevent damage to equipment.
4. Check the Specification Control drawing for weight and dimensions of the collector and components to ensure adequate crane capacity.
5. Lift collector and accessories separately and assemble after collector is in place.
6. Use drift pins to align holes in section flanges during assembly.

Typical Installation

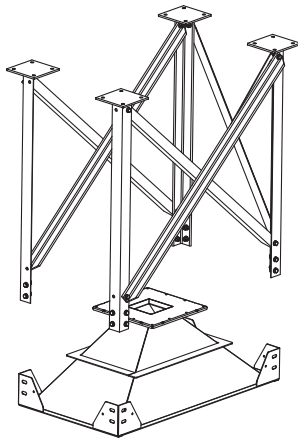

Steps 1-2

1. Place hopper discharge-side up on ground or other level surface and attach legs to hopper.
2. Assemble leg cross braces.
3. Turn hopper and leg assembly over and lift into position over anchor bolts.
4. Level hopper.
5. Tighten all fasteners securely, including all anchor bolts.



Tighten all hardware before removing crane.

- 6.* Apply 1/4-in diameter rope-type sealant to hopper flange.
7. Lift collector over leg and hopper assembly and lower slowly.
8. Secure with bolts, washers, and nuts supplied.
- 9.* Apply 1/4-in diameter rope-type sealant around inlet opening.
10. Lift inlet onto collector. Secure with bolts, washers, and nuts supplied.



Tighten all hardware before removing crane.

11. Remove crane.
12. Apply sealant to hopper/cabinet and cabinet/inlet seam.

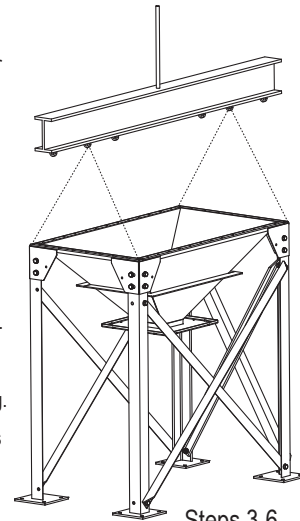

Steps 3-6

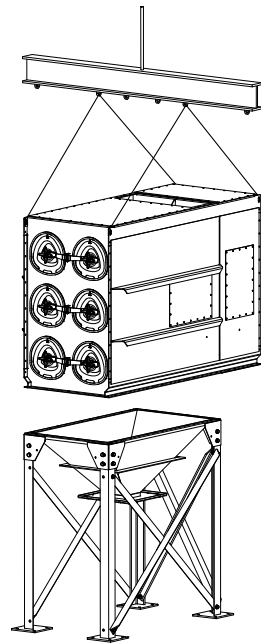

Steps 7-9

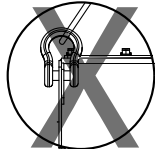
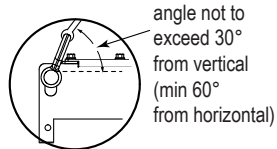

Apply sealant after marriage of hopper to cabinet and cabinet to inlet seam (step 12)

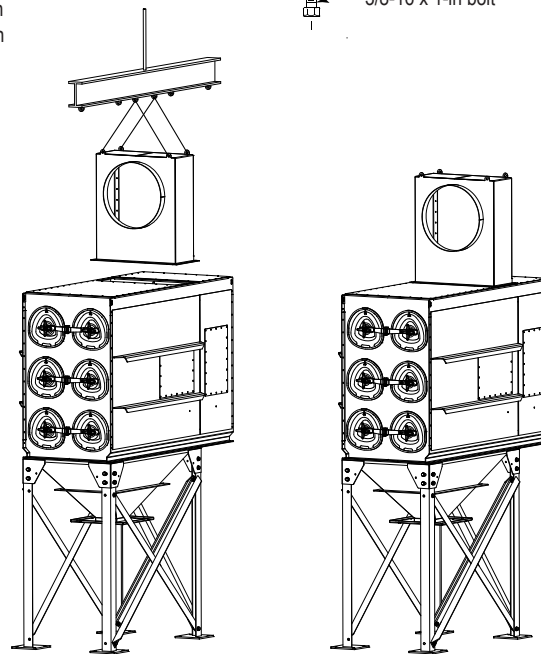
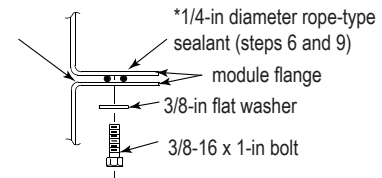

Step 10

*The 1/4-in diameter rope-type sealant supplied with the collector is temperature sensitive. It may soften and become difficult to work with at elevated temperatures. Store rope-type sealant in a cool location before use.

Typical Installation

Standard Equipment

Field Assembly

Field assembly of collector may be required due to truck capacity, crane capacity, or specific customer requirements. A detailed instruction drawing, shipped with each collector will provide specific assembly and lifting instructions.

Hopper Installation

There are four hopper styles offered for the Downflo Evolution. A single module hopper spanning a single collector module with two or three filter columns. A double module hopper spanning a pair of collector modules with two filter columns thereby accommodating four filter columns. A taller, steeper, single module hopper spanning one collector module with two filter columns. A single module screw conveyor hopper spanning one collector module with two filter columns. All four hopper styles except the screw conveyor hopper provide a 10-inch square discharge opening. The screw conveyor hopper provides a single 18-inch discharge opening.

Leg Installation



Anchors must comply with local code requirements and be capable of supporting dead, live, wind, seismic and other applicable loads.

Anchor sizes shown are provisional, as final anchor sizing will depend on jobsite load conditions, equipment location, foundation/framing design variables and local codes.

Consult a qualified engineer for final selection of suitable anchors.

Temporary support is required until all legs and cross-bracing are in place.

Leg sets for standard collector sizes are shown in the Rating and Specification Information. Reference Typical Foundation Anchor and leg assembly drawing shipped with the collector prior to starting assembly.

1. Prepare the foundation or support framing in the selected location. Locate and install anchors.
2. Set the hopper on the ground or a flat surface with the collector connection flange down. The discharge opening on the hopper base should be oriented up.
3. Use drift pins to align holes.
4. Reference the Leg Positioning and Leg and Cross Brace Assembly drawings. Attach the legs to the hopper gussets using the hardware supplied.
5. Join multiple hoppers together at hopper gussets using the hardware supplied. Do not tighten hardware at this time.
6. Turn leg and hopper assembly over and position over anchor bolts. Secure each leg pad to the foundation anchor bolts with customer-supplied flat washers and nuts. Do not tighten hardware at this time.
7. Level hopper.
8. Tighten all hardware securing legs, cross braces, hopper gussets, and foundation anchor bolts.



Tighten all hardware before removing crane to prevent personal injury and/or property damage.

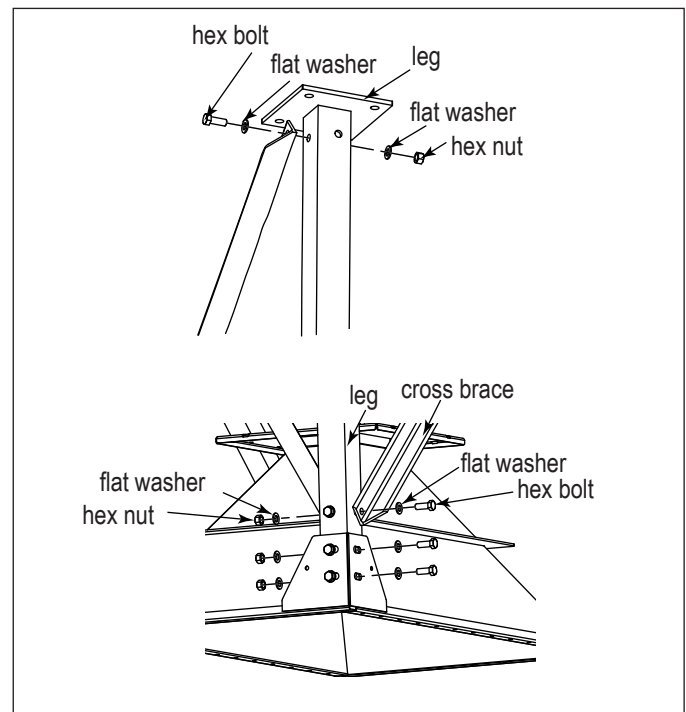

Leg and Cross Brace Assembly

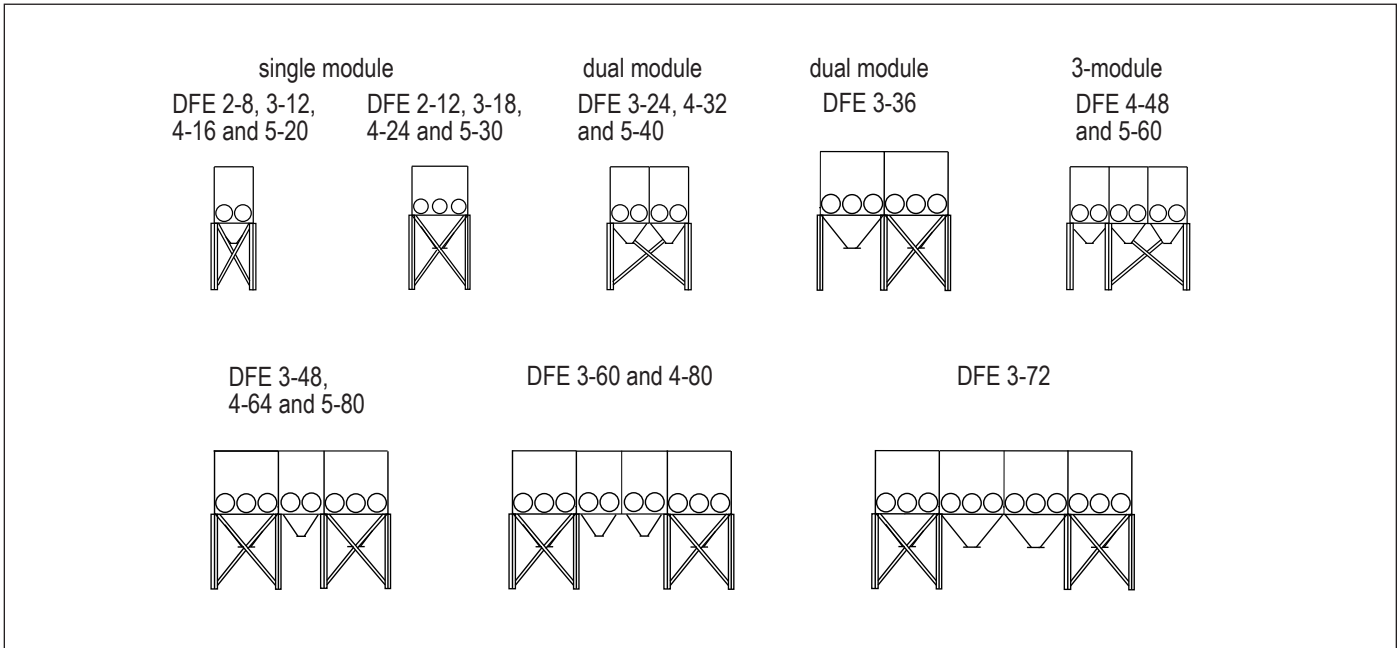

Leg Positioning

Platform and Ladder Installation



To avoid possible severe injury or equipment damage do NOT use hand rails or ladders as a lifting point.

Locate platforms and ladders to minimize risk of injury from site specific hazards including explosion relief panels.

NOTICE

Install the platform and ladder only after the filter housing and hopper assemblies are securely fastened to avoid damaging the platform or ladder.

For a list and schematic of components, refer to the ladder and platform (if applicable) assembly drawings shipped with the collector.

For single modules, the platform is available for standard and steep hoppers with ladder access on the left or right side of the platform. On dual modules and larger, the platform is available for standard hoppers only with ladder access on the left or right side of the platform. Complete installation and assembly instructions are shipped with the platform.



Dropping the platform can result in personal injury and/or property damage. Secure the platform assembly to the crane or forklift with straps or clamps.

Platform

1. Pre-assemble the platform according to the instructions shipped with the platform. The hardware and placement is called out on the assembly drawing.
2. Lift the assembled platform into position and secure following the assembly drawing instructions.
3. Tighten all hardware before removing crane or forklift.
4. Check platform hardware each time the platform is used.

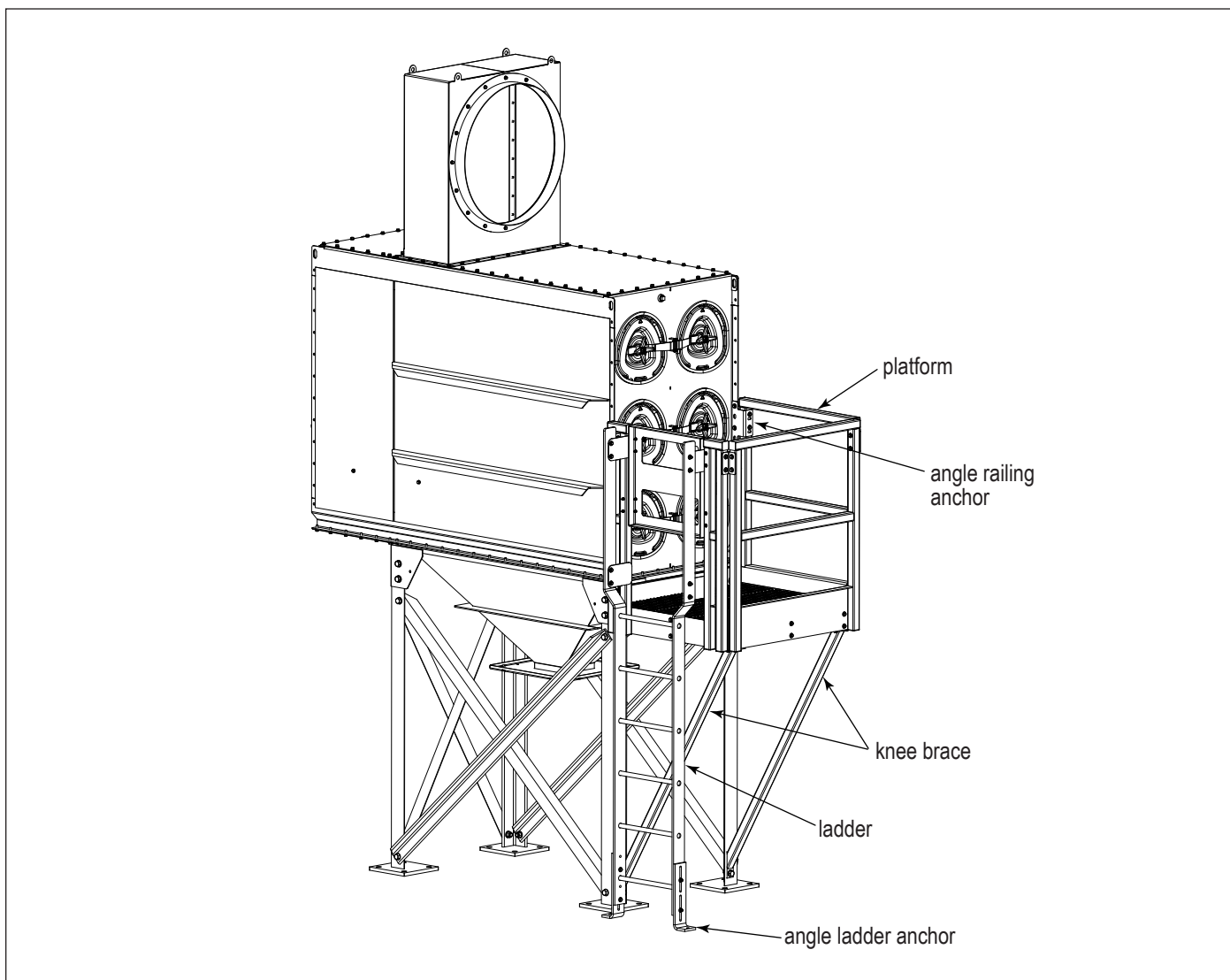

Ladder Installation

Module Assembly

Two cranes are required to lift and assemble modules.

1. Remove the protective cover from the end of each module.
2. Remove one column of access covers, filters, venturis, and yokes from the joint side of each module as shown in Detail A.
3. Remove outlet cover from the bottom of the clean-air plenum and set aside.
4. Apply a generous amount of sealant to one module to create an airtight seal between the clean- and dirty-air plenums as shown in Detail B.
5. Lift both modules into position using two cranes.
6. Use drift pins to align the bolt holes in the mating flanges.

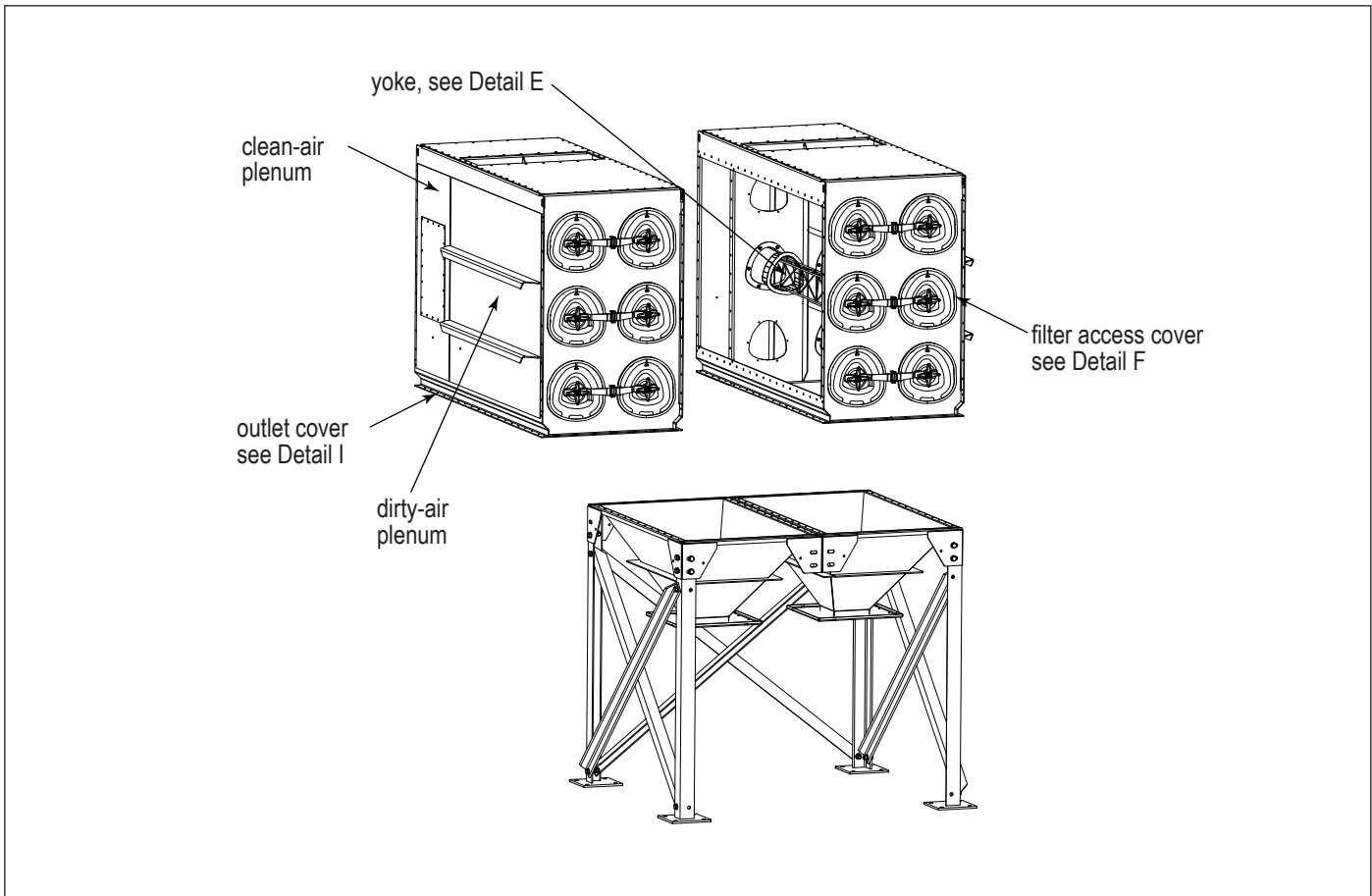

Detail A

7. Bolt the modules together using 1/2-13 and 3/8-16 x 1 1/4-in bolts, washers and nuts as shown in Details B, C and D. Do not tighten hardware at this time.
8. Check that all joints and flanges are flush and tighten hardware starting with the joint between the clean- and dirty-air plenums. Remove excess sealant.

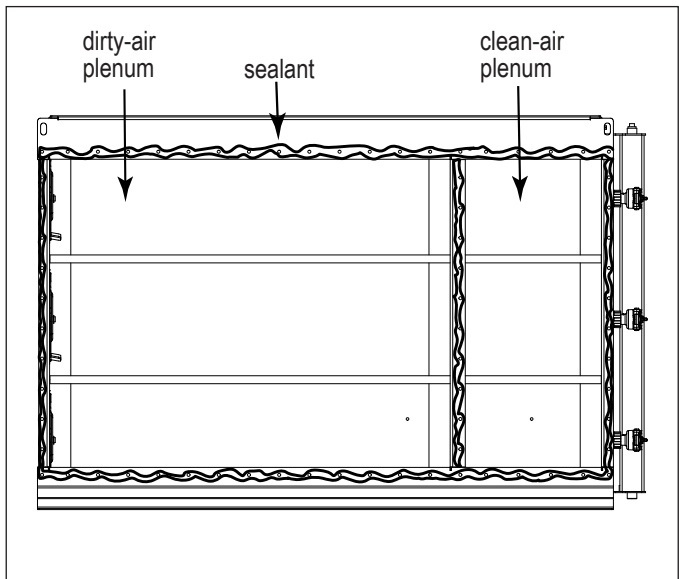

Detail B

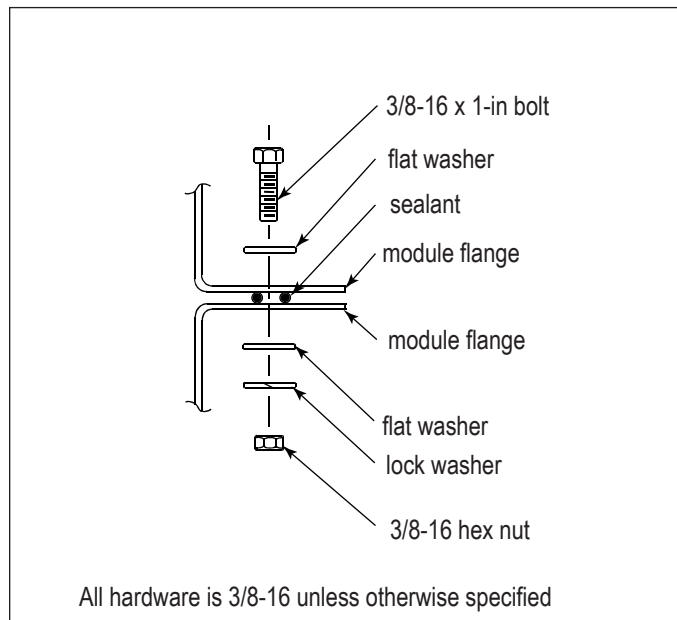

All hardware is 3/8-16 unless otherwise specified

Detail D

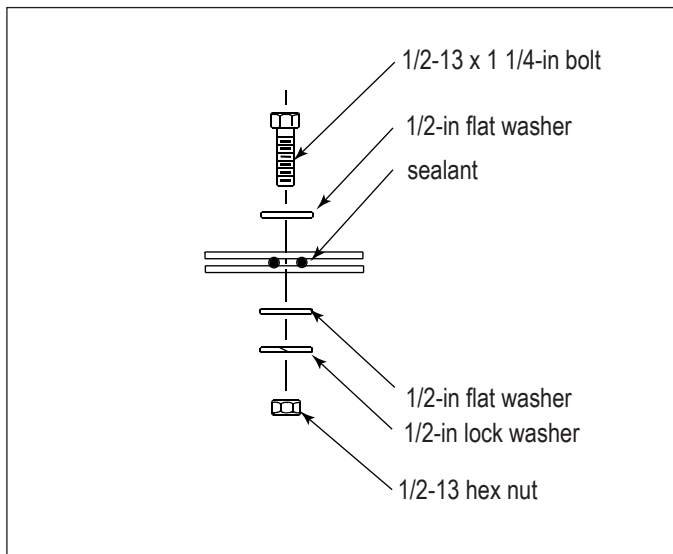

Detail C

Yoke, Venturi and Filter Installation

NOTICE

Installing yokes requires two people.

1. From the clean air plenum (to access, remove the outlet cover, see Detail I), thread a 3/8-in hex jam nut and 3/8-in flat washer to the shoulder of each of the three yoke rod ends. See Detail G.
2. Starting at the top access port work downward. Orient the yoke as shown in Detail E and insert into the housing so the yoke is positioned in the appropriate holes in the tube sheet. From the filter section, have one person hold the yoke in position while another person installs a 3/8-in flat washer and 3/8-in hex nut on each yoke rod end from the clean-air plenum. Do not tighten hardware at this time.
3. Adjust jam nut against the filter cartridge panel. Have one person hold the yoke in position as shown in Detail F while another person tightens the three hex nuts from the clean-air plenum. Repeat to install all yokes.
4. Apply sealant to venturi as shown in Detail H. Slide venturi over the yoke with sealant end first. Hold venturi in place while installing venturi hardware (7/16 x 3/4-in thread forming screws and 1/2-in gasket washers) from the clean-air plenum.
5. Slide the filter cartridges into the collector on the yoke gasket-end first. Replace access cover and tighten securely by hand following instructions found in Maintenance Information. Repeat for all filter cartridges.
6. Replace the outlet cover on the bottom of the clean-air plenum shown in Detail I.

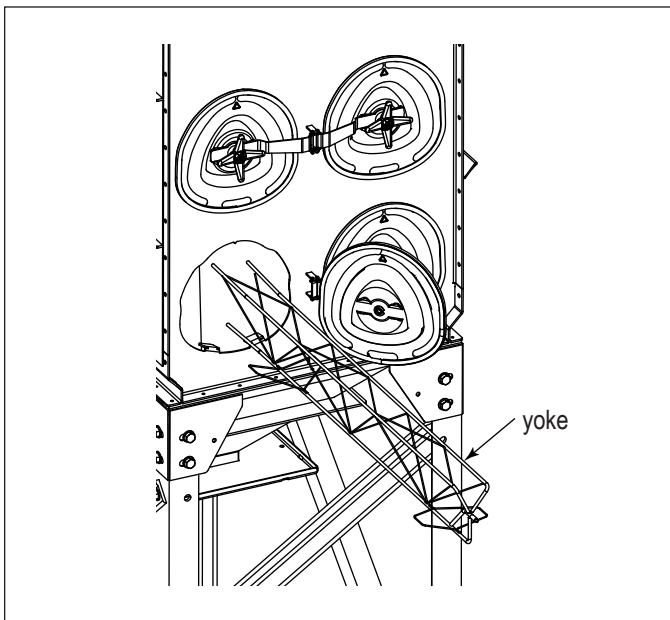

Detail E

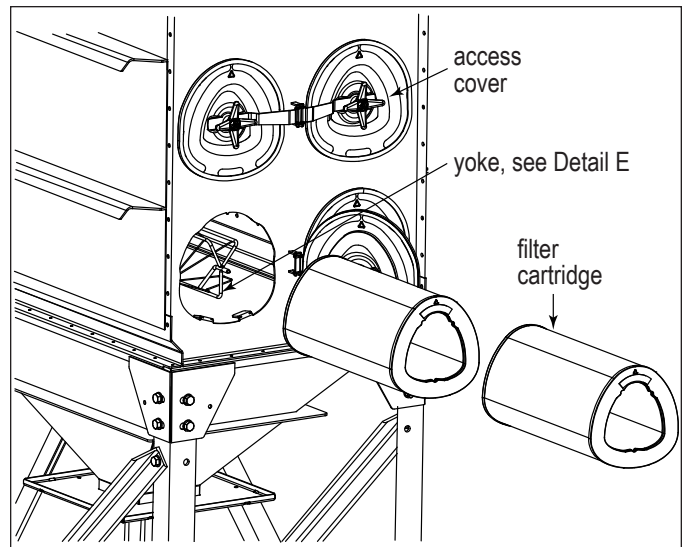

Detail F

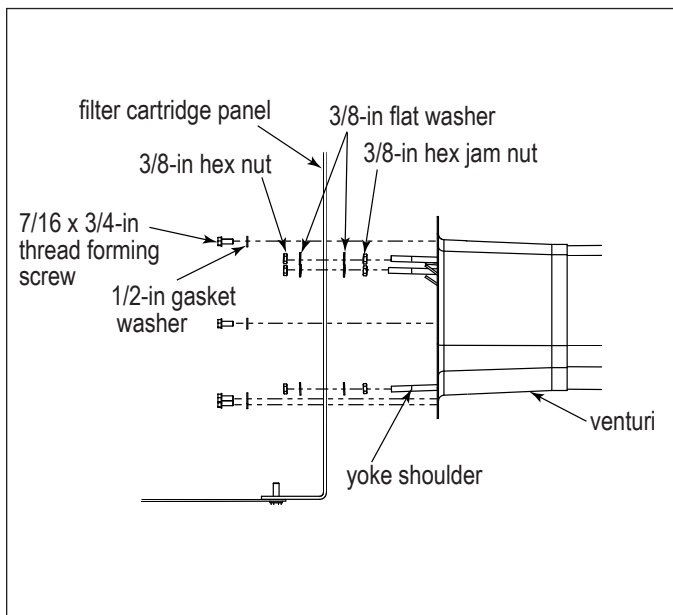

Detail G

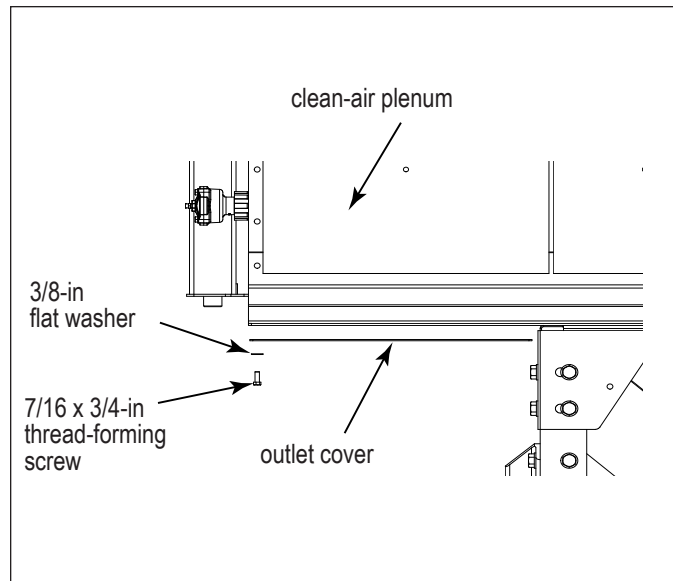

Detail I

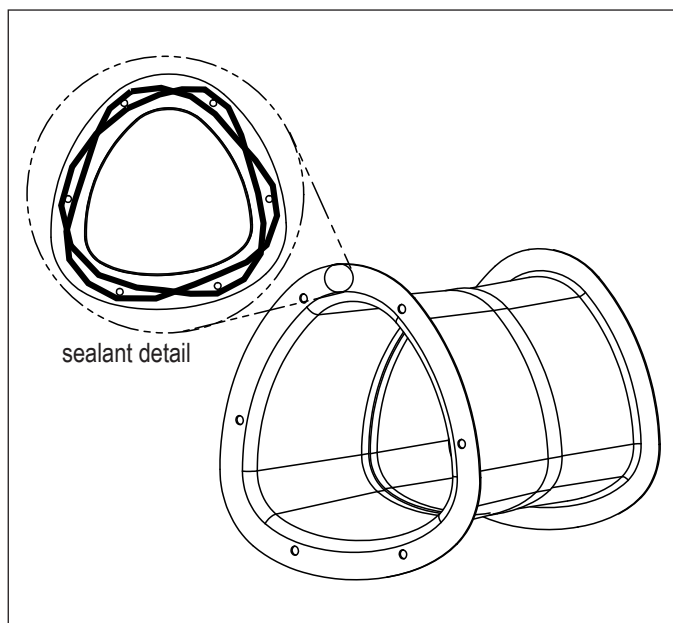

Detail H

Compressed Air Installation



Turn compressed air supply OFF, bleed and lock out lines before performing service or maintenance work.

A safety exhaust valve should be used to isolate the compressed air supply. The safety exhaust valve should completely exhaust pressure in the collector manifolds when closed, should be capable of being interlocked with fire or explosion mitigation equipment and should include provisions to allow closed-position locking.

NOTICE

Do not set compressed-air pressure above 100-psig as component damage can occur.

All compressed air components must be sized to meet the system requirements of supply pressure.

The compressed-air supply must be oil and moisture free. Contamination in the compressed air used to clean filters will result in poor cleaning, cleaning valve failure, or poor collector performance.

Purge compressed-air lines to remove debris before connecting to the collector's compressed-air manifold.

1. Remove the pipe plug from the collector's air manifold and connect the compressed-air supply lines. Use thread-sealing tape or pipe sealant on all compressed-air connections.
2. Install a shut-off valve, bleed-type regulator with gauge, filter, and automatic condensate valve in the compressed-air supply line.

Electrical Wiring



Electrical installation, service, or maintenance work must be performed by a qualified electrician and comply with all applicable national and local codes.

Turn all power off and lock out all power before performing service or maintenance work. It is not unusual for the equipment to be operated from a remote location so equipment may start or stop unexpectedly.

The appropriate wiring schematic and electrical rating must be used. See collector's rating plate for required voltage.

Do not install in classified hazardous atmospheres without an enclosure rated for the application.

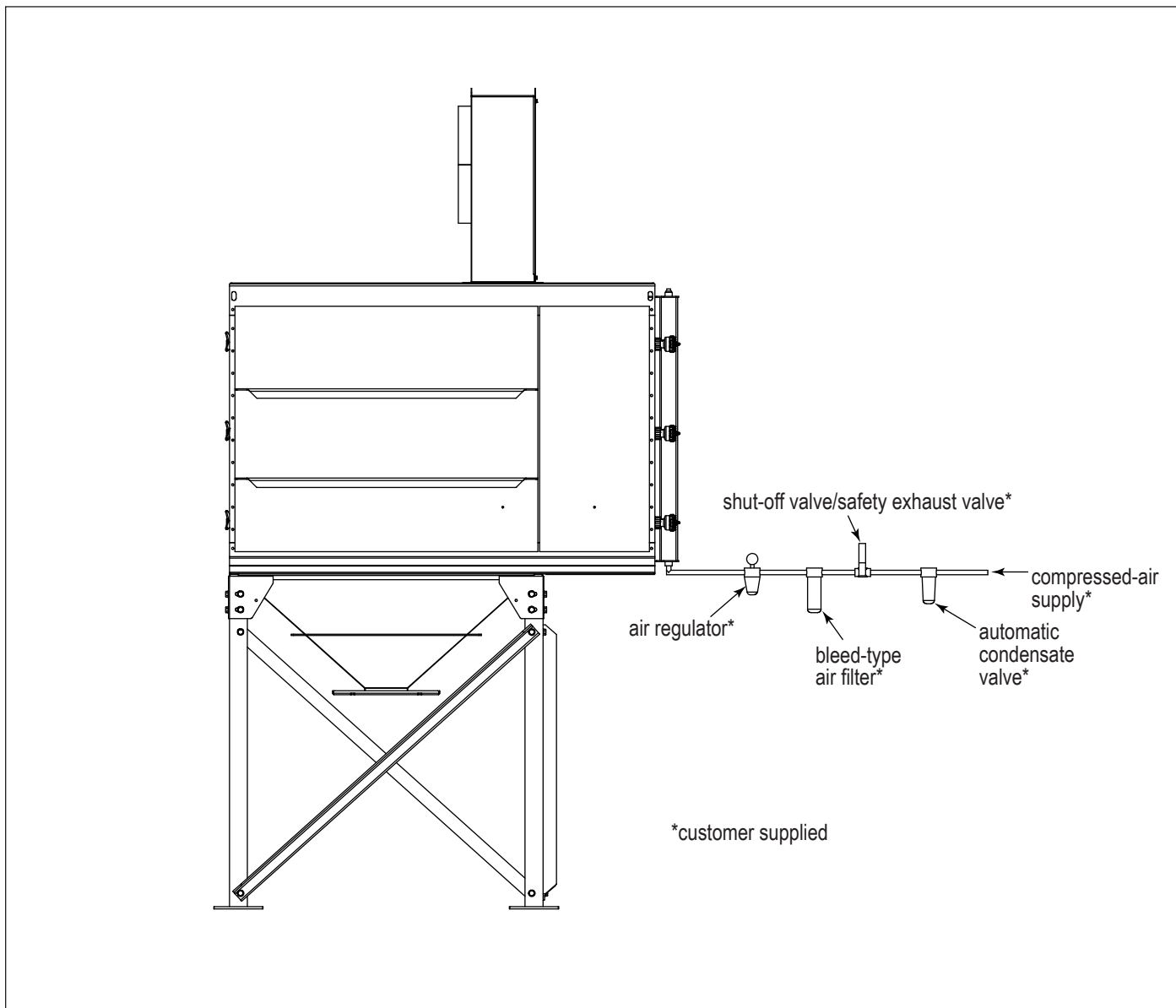

Compressed Air and Component Installation

Solid-State Timer Installation



Electrical installation, service or maintenance work during installation must be performed by a qualified electrician and comply with all applicable national and local codes.

Turn all power off and lock out all power before performing installation, service, or maintenance work.

Do not install in classified hazardous atmospheres without an enclosure rated for the application.

1. Using the wiring diagram supplied with the timer assembly, wire the fan motor, fan-motor starter, solid-state timer, and solenoid valves. Use appropriate wire gauge for rated amp load as specified by local codes.
2. Plug the program lug into the pin that corresponds with the number of solenoid valves controlled. Set the switch positions on the DIP switch labeled LAST CHANNEL to the corresponding number of pulse valves using the chart printed on the timer board.
3. With power supply ON, check the operation of the timer and valves. The valves should open and close sequentially at factory set 10-second intervals.
4. If a gauge or similar device is used to control the solid-state timer, the jumper on the pressure switch portion of the timer should be removed. The solenoid valves pulse only when the differential pressure reaches the high-pressure setpoint. The valves will continue to pulse until the low-pressure setpoint is reached.

NOTICE

The solid-state timer voltage must match the voltage of the rating of the timer provided (typically 120VAC).

Do not mount the solid-state timer directly to the collector as mechanical vibration can damage the timer.

Solenoid Connection

The collector is equipped with electric solenoid valves (typically 120V) that control the pulse-cleaning valves, which in turn release compressed air from the manifold to clean the filters.

Solenoid enclosures are mounted near or on the collector's compressed-air manifold.

Wire the solenoids to the solid-state timer following the wiring diagram supplied with the collector. Filter life and cleaning operation will be affected if not wired correctly.

Timer and Solenoid Specifications

Power to the solid-state timer is supplied to Terminals L1 and L2, which are intended to operate in parallel with the fan starter's low-voltage coil. On fan start-up, power is supplied to the timer and the preset OFF time is initiated. At the end of the OFF time, the timer energizes the corresponding solenoid valve to provide the ON time cleaning pulse for one diaphragm valve and then steps to the next until all filters have been cleaned.

To pulse when the fan is OFF, install a toggle switch as shown on the Solid-State Timer Wiring Diagram. When the toggle switch is ON, the timer receives power and energizes the solenoid valve pulse-cleaning operation even though the fan is turned OFF.

Input
105-135V/50-60Hz/1Ph

Output Solenoids
The load is carried and turned ON and OFF by the 200 watt maximum-load-per-output solid-state switch.

Pulse ON Time
Factory set at 100-milliseconds, or 1/10-second.

NOTICE

Do not adjust pulse ON time unless the proper test equipment is available. Too much or too little ON time can cause shortened filter life.

Pulse OFF Time
Factory set at 10-seconds, adjustable from 1.5-second minimum to maximum 30-seconds.

Operating Temperature Range
-20° F to 130° F

Transient Voltage Protection
50 kW transient volts for 20-millisecond duration once every 20 seconds, 1% duty cycle.

Solenoid Valves
115-Volt at 19.7 watts each

Compressed-Air
Set compressed-air supply pressure to a level suitable for the filters (90-psig). The pulse-cleaning controls are factory set to clean one or more filters every 10-seconds during a cleaning cycle.

NOTICE

Do not increase supply pressure above 90-psig as component damage can occur.

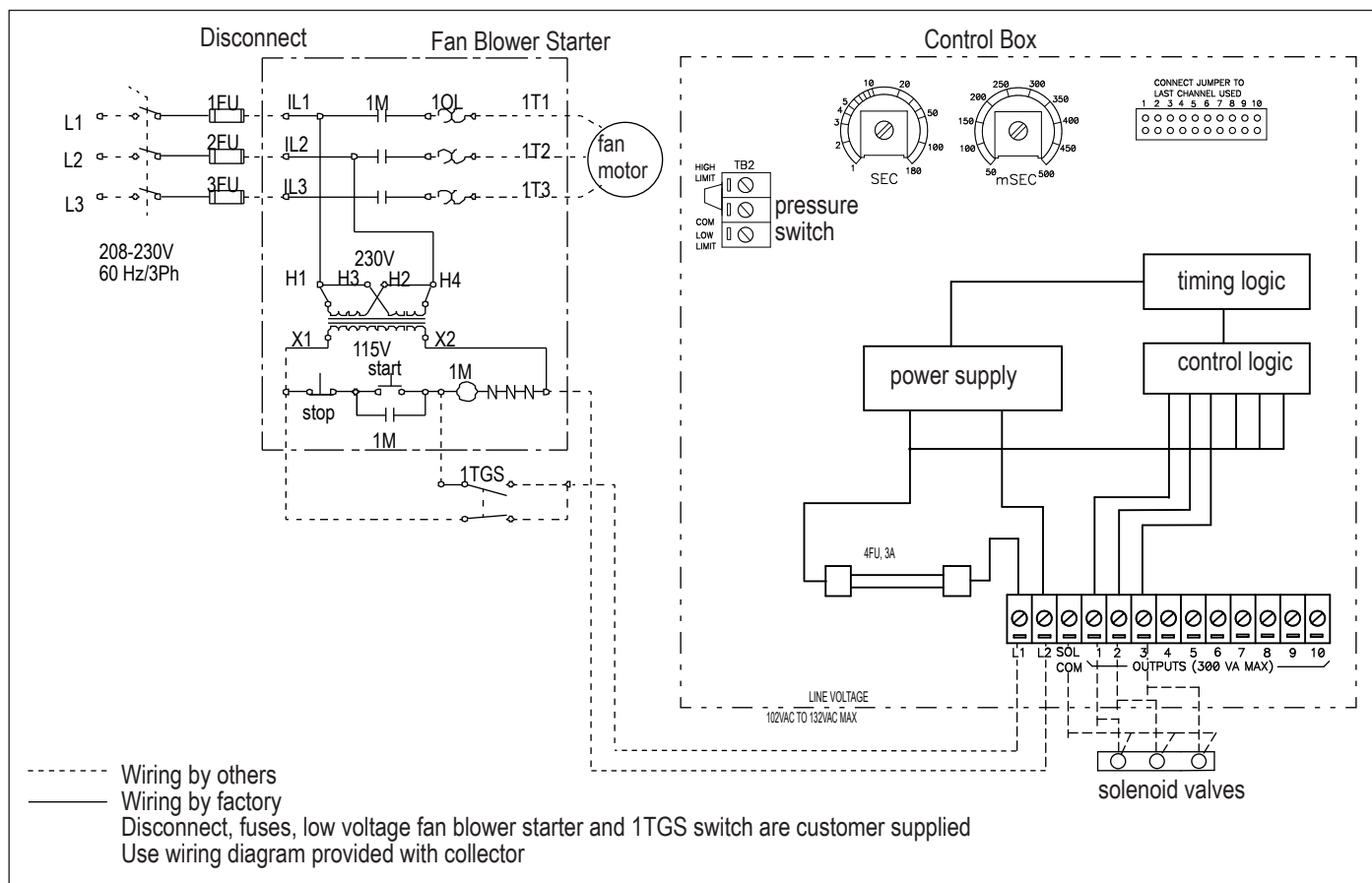

Typical Wiring Diagram

iCue Gateway Installation



The iCue Gateway should not be used to detect, monitor, warn, or alert personnel to hazards, potential safety issues, or combustion risks. Users should not rely on readings from the product to provide emergency or hazard prevention or for emergency response activities and decisions. Users remain solely responsible for maintaining a safe work environment. All dust collection equipment and accessories should be operated and maintained in accordance with the manufacturer's instructions.

DFE collectors are designed with connectivity in mind through the iCue platform. The platform utilizes an iCue Gateway that captures data from sensors and transmits it wirelessly via a cellular connection to the web-based Donaldson iCue application. This platform operates independently of the dust collector control system.

The iCue Gateway utilizes internal sensors for sensing filter differential pressure, airflow data and compressed air pressure of the cleaning manifold. The gateway also has inputs for Donaldson approved optional sensors. The platform utilizes a cellular connection to transmit sensor data to the Donaldson iCue application. The cellular data plan and preinstalled SIM card are provided by Donaldson. The SIM card will only work with Donaldson's service and should not be removed.

For additional installation information on the iCue Gateway operation or instruction on connecting additional sensors, refer to the installation and operation manual for the iCue Gateway.

DFE collectors may include an iCue Gateway in one of three mounting configurations:

- Mounted in a common enclosure with collector cleaning control components
- Pre-mounted to the rear of the dust collector with a junction box
- Shipped loose for remote field installation



Scan the QR on the right for a video highlighting the installation and set-up process for the iCue Gateway.

Common Enclosure with Cleaning Control Components

The collector has been provided with an iCue Gateway mounted in a common enclosure with the cleaning control components. Power is provided to the iCue Gateway through the common connection for cleaning controls. If required, connect the compressed air sensor to the coupling provided on the compressed air manifold (located on the rear of the collector). A compression fitting at the enclosure and an a 1/4-in NPT coupling at the manifold are provided for these connections.

Note: Install antennae, shipped inside enclosure, as shown once controller has been mounted.

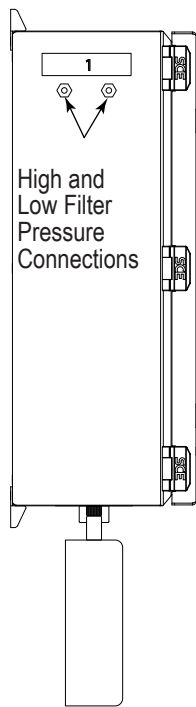

Left Side View

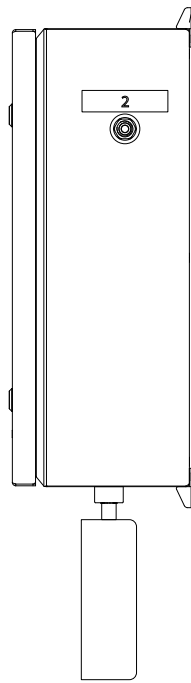
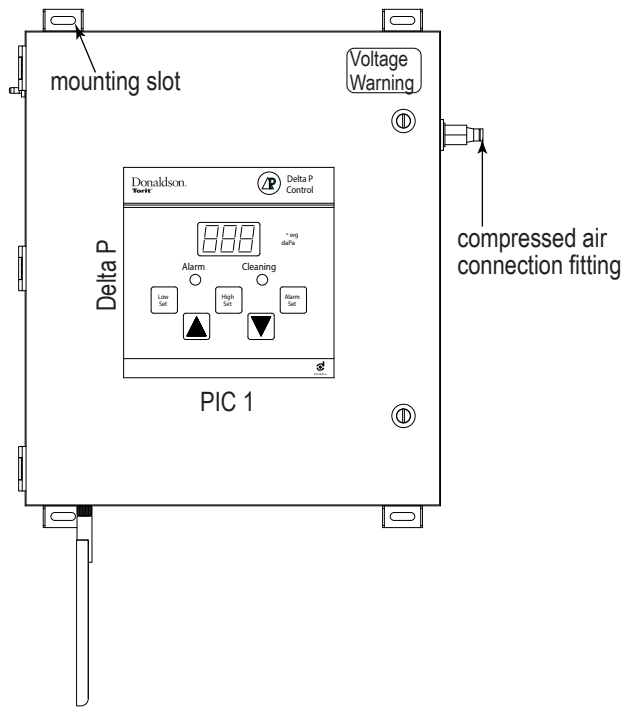

Right Side View

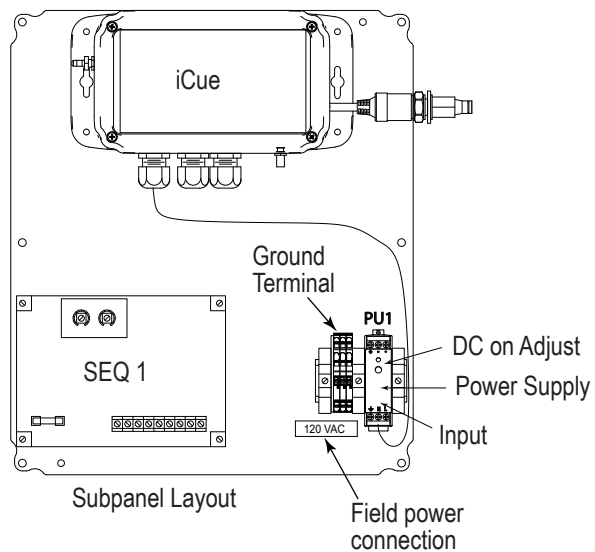

iCue Installation Pre-Mounted to Collector

The collector is equipped with an iCue Gateway kit mounted to the rear of the collector including a junction box. To connect the kit, 110/60/1 VAC power must be supplied to the junction box. Additional installation and connection instructions can be found on the reference drawing shipped with the dust collector.

NOTICE

For installations using 24VDC power, the iCue power supply, cable and junction box should be removed. The iCue Gateway can be powered directly by the 24VDC. If the iCue Gateway is unable to connect to the cellular network, it can be relocated or an antennae extension is available.

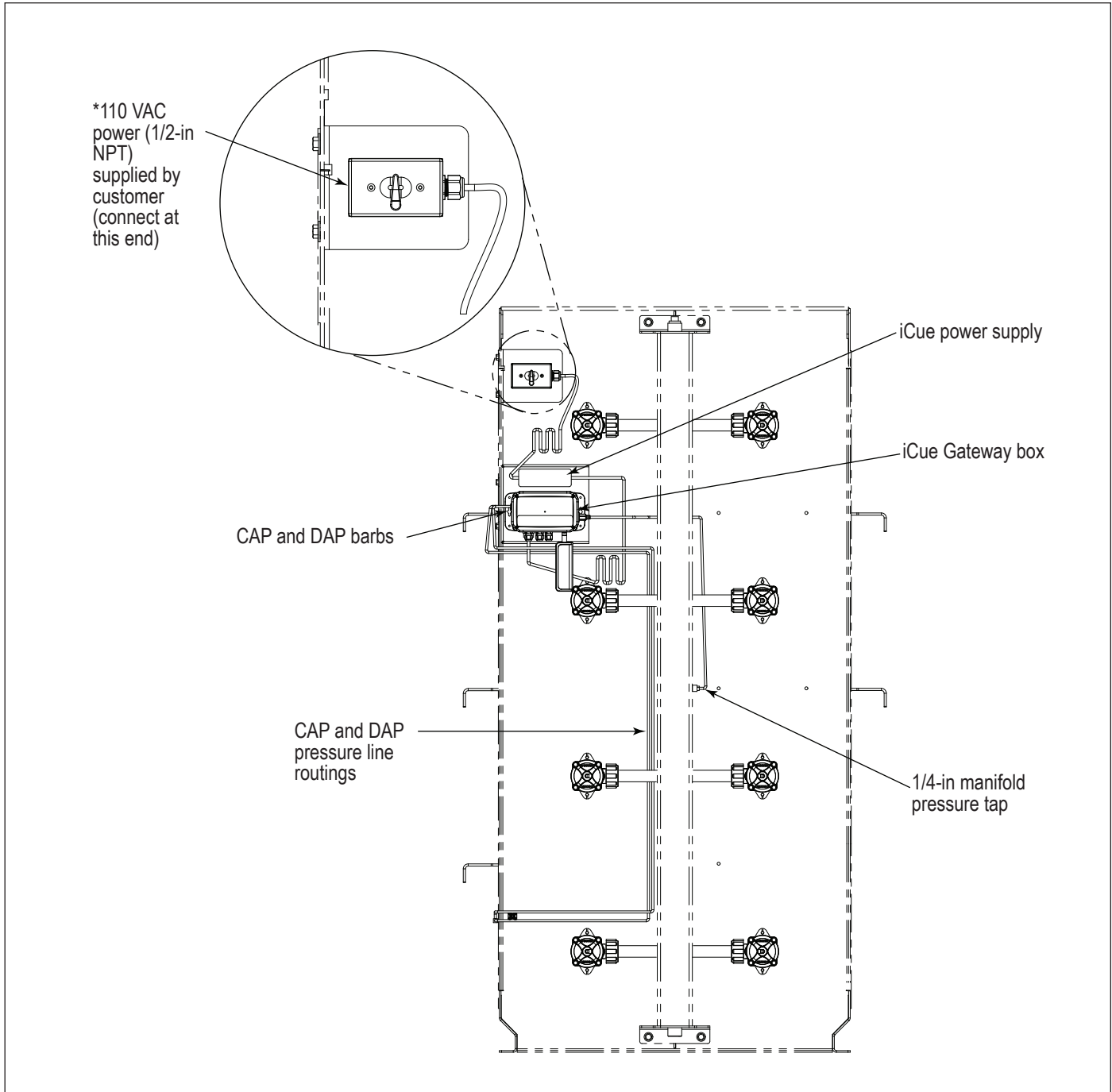

iCue Kit Shipped Loose

In some cases an iCue kit will be shipped loose for field installation or may be added after the initial shipment. The kit will include an iCue Gateway, antennae, items to mount the iCue Gateway, a power supply, tubing and fittings. The iCue Gateway can be directly powered by a 7-32 VDC input power source. If that voltage is not available, the kit is provided with a power supply to convert a 110 VAC power source to a 24 VDC output supply which is connected to the iCue Gateway. Refer to the iCue Gateway Installation and Operation Manual for additional detail including sensor connection.

Connections should be made to the collector dirty and clean air pressure taps along with compressed air manifold coupling using components provided with the kit.

Note: The iCue Gateway can be rigidly mounted or placed using magnets provided with the kit and following the instructions located in the iCue Gateway Installation and Operation Manual.

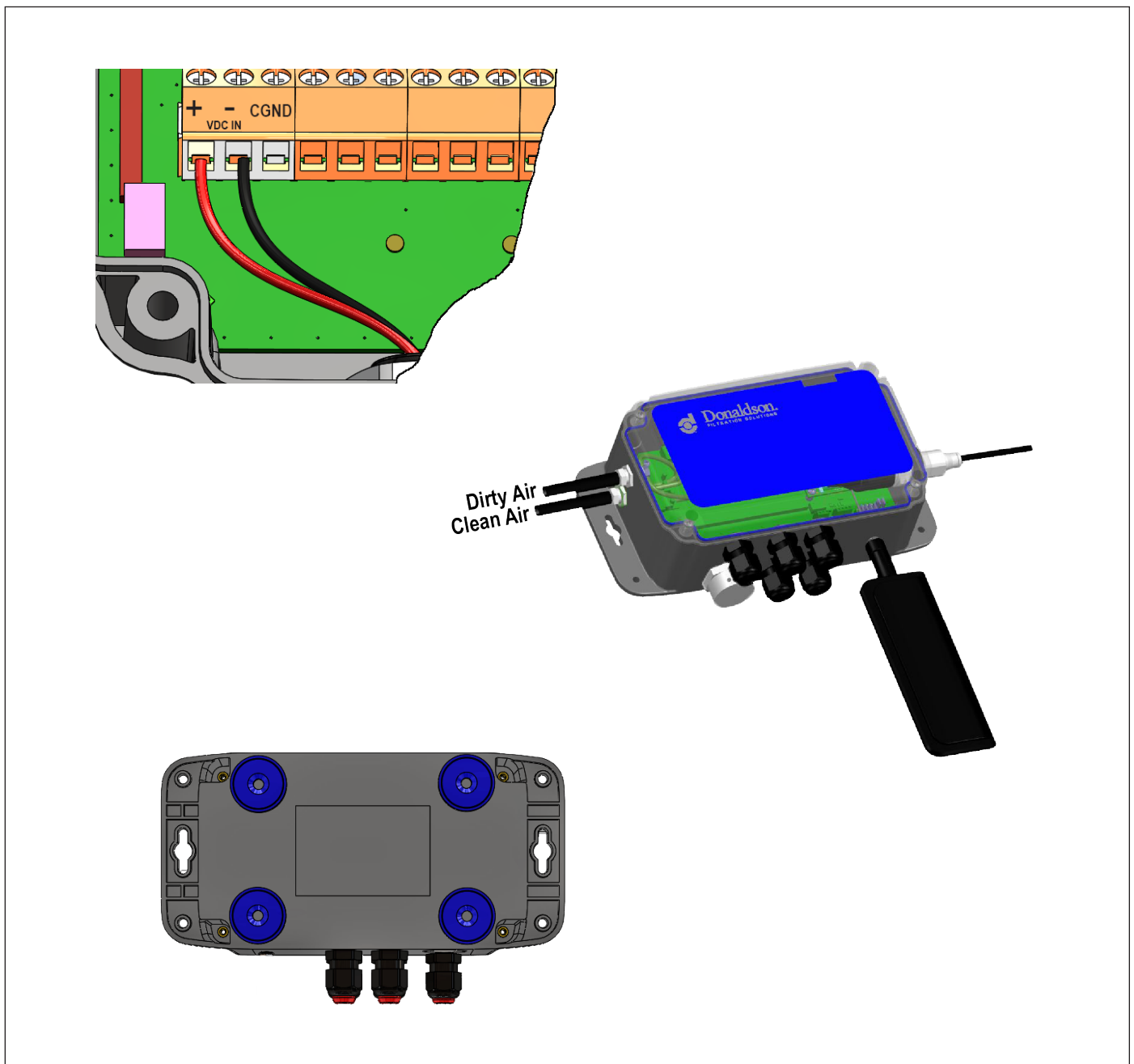

Options and Accessories

Fan Controls



Failure to lift the fan correctly can result in severe personal injury and/or property damage.

Use appropriate lifting equipment and adopt all safety precautions needed for moving and handling the fan.

Only qualified crane or forklift operators should be allowed to lift equipment.

To avoid personal injury and/or damage to equipment, ensure fan blowers are properly attached to equipment.

NOTICE

The use of a damper or variable frequency drive (VFD) is required to control airflow through the collector. Lack of a control damper or VFD will shorten filter life.

The collector can accept a direct mounted fan, Torit Backward Inclined (TBI) or Torit Radial Blade (TRB), to the top or side of the collector.

For complete information, see the most current version of the TBI or TRB Fan Installation, Operation and Maintenance manual.

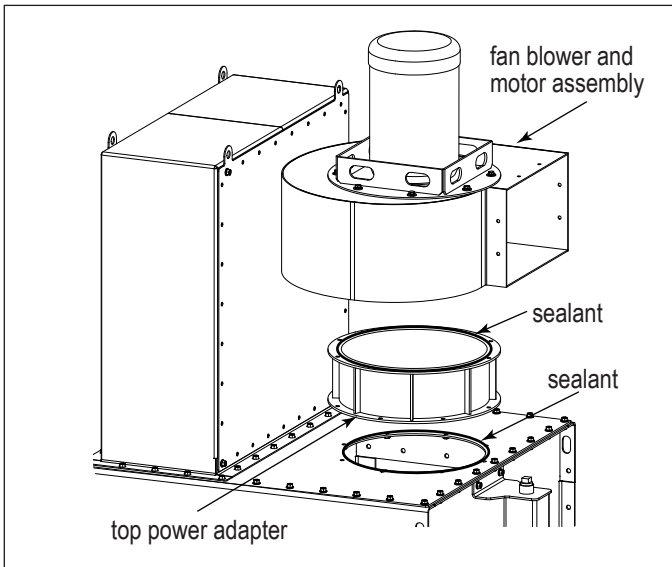

Top Mount Fan Blower Field Installation

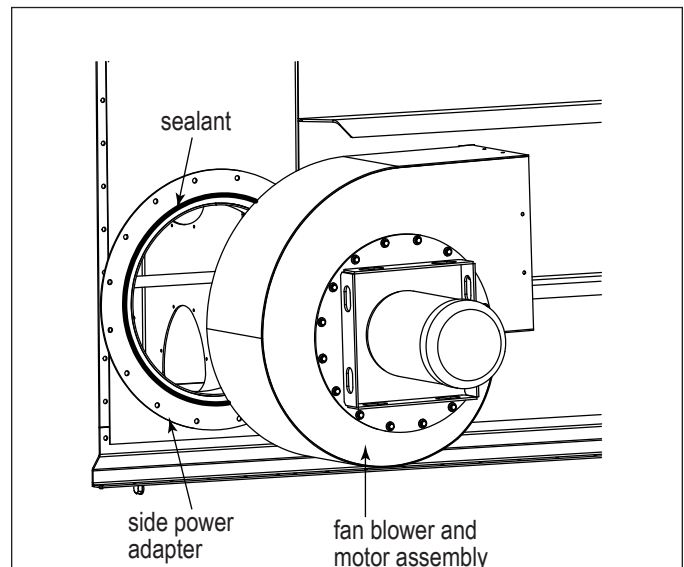

Side-Mount Fan Blower Field Installation

TBI and TRB Style Damper and Silencer Support Bracket

For complete information, see the most current version of the TBI or TRB Fan Installation, Operation and Maintenance manual.

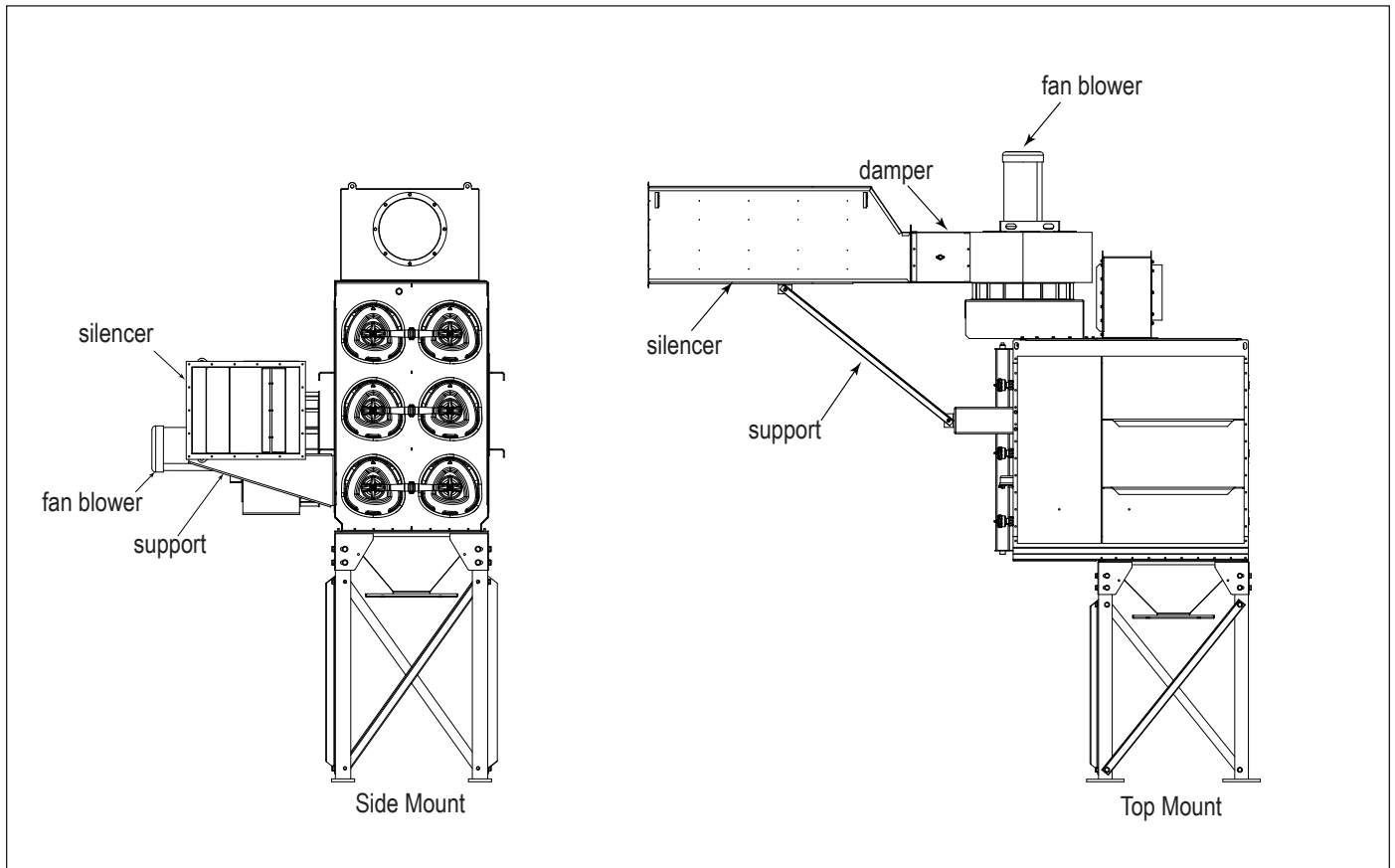

Side and Top-Mount Damper and Silencer Support Bracket

Cleaning Controls and Sensors

Magnehelic® Gauge

1. Choose a convenient, accessible location on or near the collector for mounting that provides the best visual advantage.
2. Plug the pressure ports on the back of the gauge using two, 1/8-in NPT pipe plugs supplied. Install two, 1/8-in NPT male adapters supplied with the gauge into the high- and low-pressure ports on the side of the gauges.
3. Attach the mounting bracket using three, #6-32 x 1/4-in screws supplied.
4. Mount the gauge and bracket assembly to the supporting structure using two, self-drilling screws.
5. Thirty-five feet of plastic tubing is supplied and must be cut in two sections. Connect one section of tubing from the gauge's high-pressure port to the pressure fitting located in the dirty-air plenum. Connect remaining tubing from the gauge's low-pressure port to the fitting in the clean-air plenum. Additional tubing can be ordered from your representative.
6. Zero and maintain the gauge as directed in the manufacturer's Operating and Maintenance Instructions provided.

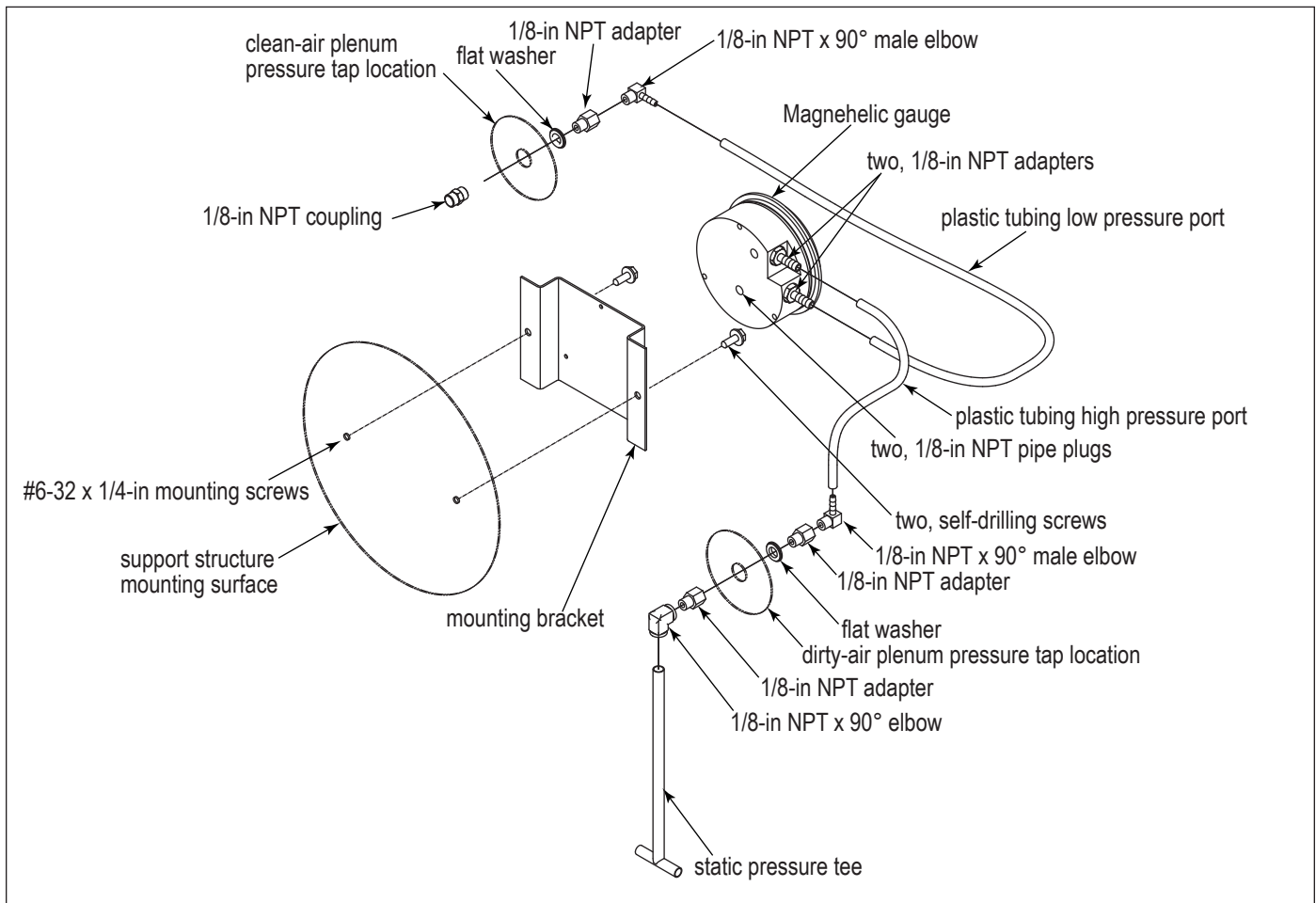

Magnehelic Gauge Installation

Photohelic® Gauge



Electrical installation, service, or maintenance work must be performed by a qualified electrician and comply with all applicable national and local codes.

Turn all power off and lock out all power before performing service or maintenance work.

Do not install in classified hazardous atmospheres without an enclosure rated for the application.

1. Choose a convenient, accessible location on or near the collector for mounting that provides the best visual advantage.
2. Mount the gauge to the remote panel or door using the mounting ring, retaining ring, and four #6-32 x 1 1/4-in screws. Do not tighten screws. Connect two, 1/8-in NPT x 1/4-in OD male adapters to the gauge's high- and low-pressure ports. Tighten screws.
3. On the back of the gauge, remove four #6-32 x 5/16-in screws and plastic enclosure. Set aside. Add two jumper wires supplied by customer. Remove the jumper from the pressure switch located on the timer board, if equipped. Using the 3/4-in conduit opening, wire the gauge as shown. Reassemble and fasten enclosure securely.
4. Thirty-five feet of plastic tubing is supplied and must be cut in two sections. Connect one section of tubing from the gauge's high-pressure port to the pressure fitting located in the dirty-air plenum. Connect remaining tubing from the gauge's low-pressure port to the fitting in the clean-air plenum. Additional tubing can be ordered from your representative.
5. Zero and maintain the gauge as directed in the manufacturer's Operating and Maintenance Instructions provided.
6. To install the Photohelic Gauge mounted in a NEMA 4, Weatherproof Enclosure, follow Steps 4 and 5.

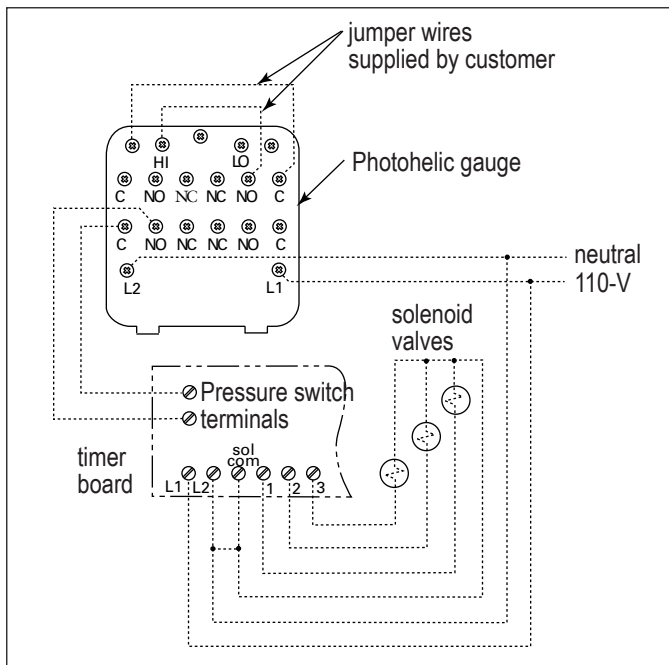

Photohelic Gauge Wiring Diagram

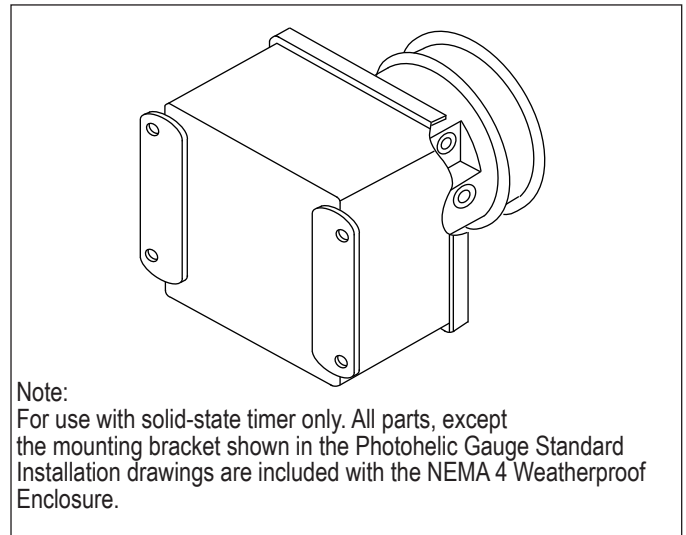

Photohelic Gauge in Optional NEMA 4 Weatherproof Enclosure

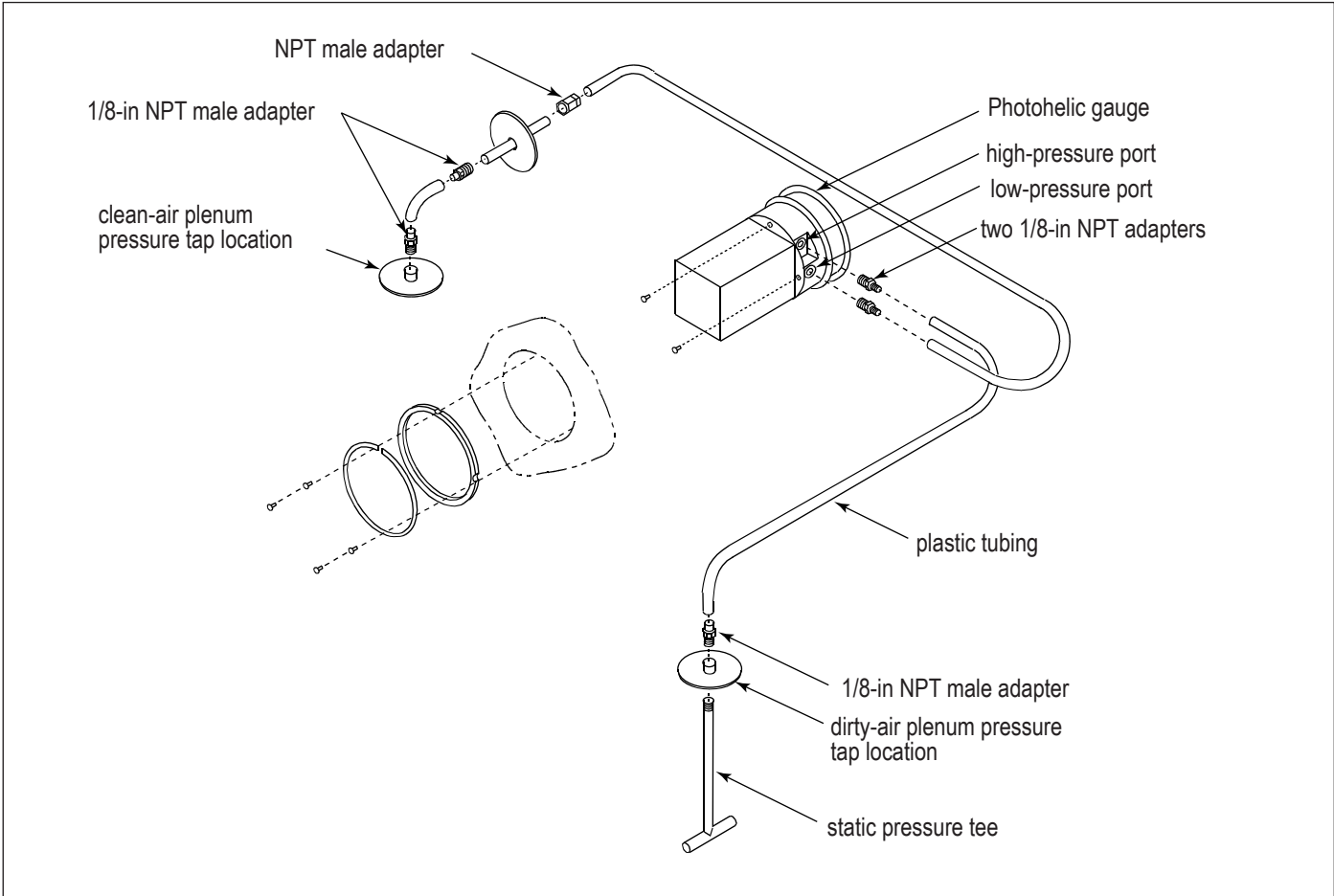

Photohelic Gauge Installation

Delta P Control

For complete information, see the most current version of the Delta P Installation, Operation, and Maintenance manual.



Delta P Control Display

Delta P Plus Control

For complete information, see the most current version of the Delta P Installation, Operation, and Maintenance manual.

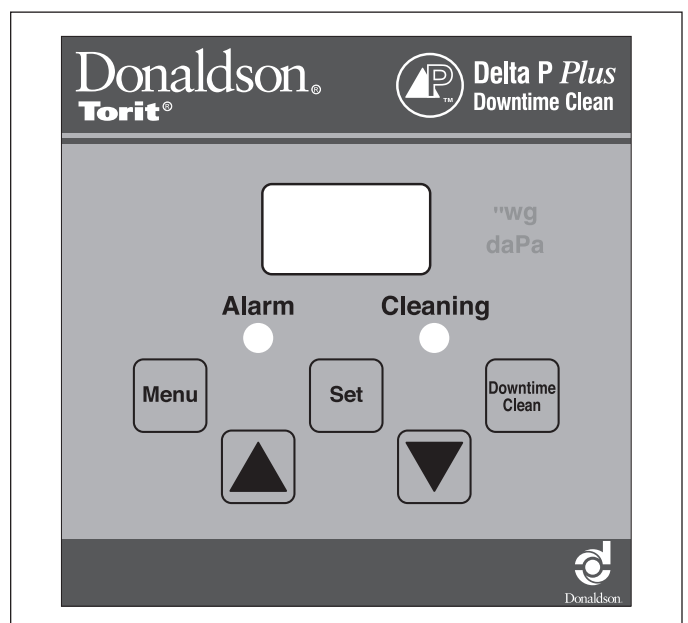

Delta P Plus Control Display

Hopper Discharge Accessories



Turn all power off and lock out all power to the collector and ancillary equipment before accessing the inside of the hopper and before performing service or maintenance work.

Most dusts present safety and health hazards that require precautions.

Wear eye, respiratory, head and other protective equipment suitable for the type of dust.

Reference Appendix B for Clean Change Bag-In/ Bag-Out Filter and Liner System information.

55-Gallon Drum Pack



Sharp edge of slide gate may result in personal injury while closing the slide gate. Keep hands clear when operating the slide gate.

With Slide Gate

1. Place the 1/8-in gasket spacer between the hopper flange and slide gate as shown.
2. Attach the drum pack and slide gate to the hopper flange using 3/8-16 bolts, washers and hex nuts.
3. Attach the drum cover to the 55-gallon drum.
4. Use latches to secure the cover to the drum, if equipped.
5. Connect the flexible hose between the drum cover and slide gate. Secure with hose clamps.

Without Slide Gate

1. Place 1/4-in diameter rope-type sealant between the hopper flange and the drum cover mounting flange toward the inside edge of the bolt pattern.
2. Fasten using the bolts, washers, and nuts supplied.
3. Attach the drum cover to the 55-gallon drum.
4. Use latches to secure the cover to the drum, if equipped.
5. Connect the flexible hose between the drum cover and the adapter. Secure with hose clamps.

With Bag-Out Components

Note: This is not for contamination prevention or full containment purposes and is not a substitute for BIBO. Contact Donaldson Torit for selection assistance.

1. Place the BIBO hopper bag with plastic liner inside the 55-gallon drum. Position the liner upright inside the drum. It will expand and hold the bag securely to the inside of the 55-gallon drum.

Note: The 55-gallon drum is supplied by others.

2. Position the 55-gallon drum under the drum cover, attached to the hopper.
3. Draw the open end of the bag around the drum cover and through the drum cover clamp assembly. The bag will now be outside the drum cover but inside the drum cover clamp assembly.
4. Slide the open end of the bag around the collar adapter, which is located under the slide gate. Use the buckle strap to securely fasten the bag to the collar adapter.
5. Position the drum cover carefully on top of the 55-gallon drum.
6. Secure the 4 clamps of the drum cover clamp assembly to the drum by tightening the knobs. Make sure the clamps engage the top rim of the 55-gallon drum.

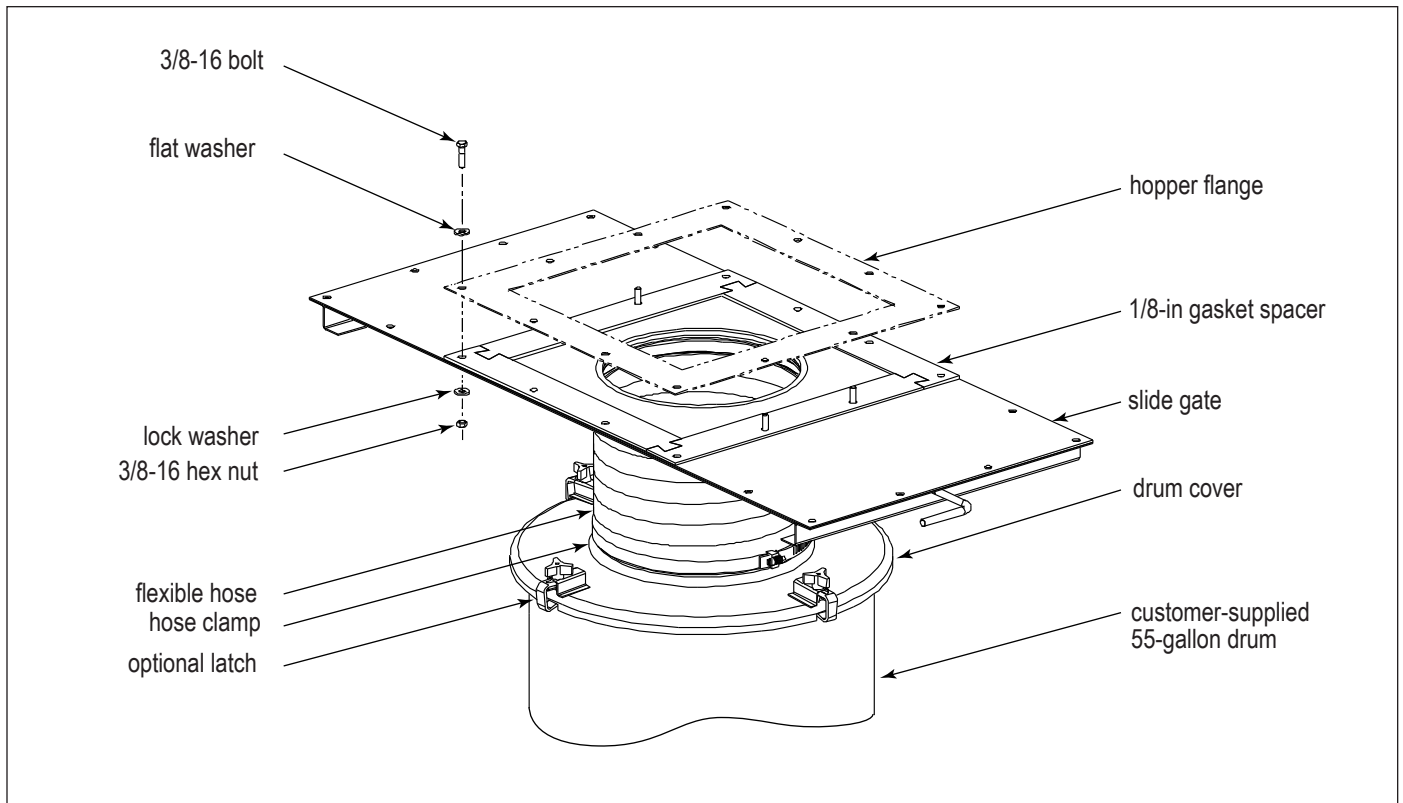

55-Gallon Drum Pack with Slide Gate

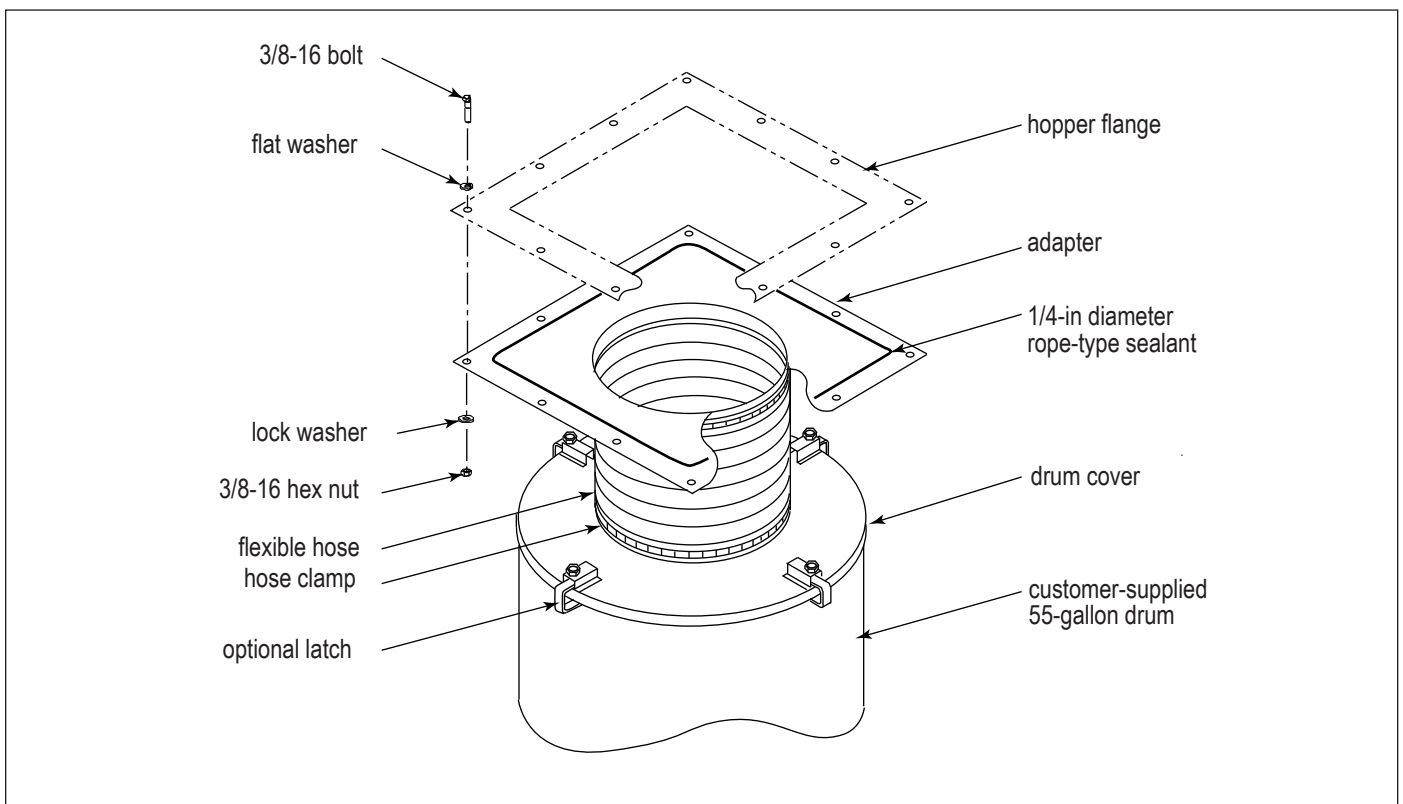

55-Gallon Drum Pack without Slide Gate

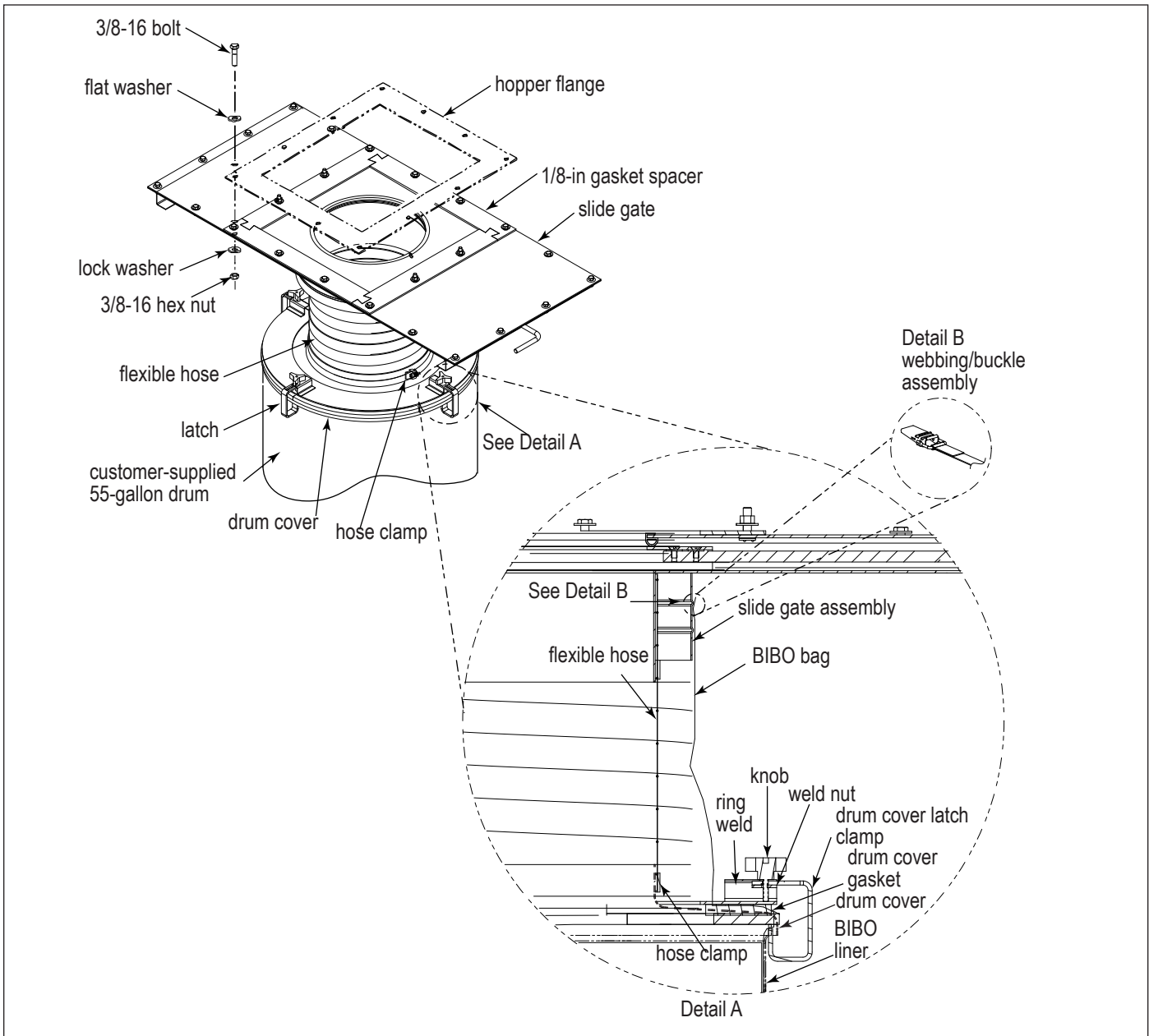

55-Gallon Drum with Bag-Out Components

Hopper Bag-Out Replacement

Note: This is not for contamination prevention or full containment purposes and is not a substitute for BIBO. Contact Donaldson Torit for selection assistance.



Turn pulse cleaning system OFF before using the Hopper Bag-Out Process.

1. Leaving the bag securely strapped to the collar adapter, loosen the four clamps on the drum cover clamp assembly.
2. Lift the ring and drum cover assembly up from the 55-gallon drum. Pull the open end of the bag through the drum cover clamp assembly from the bottom. Two people may be required to remove the bag from the drum cover assembly.
3. Remove the drum and bag assembly from under the hopper. With the bag open, remove the plastic liner from inside of the bag. Retain the plastic liner as it can be reused with the next bag.
4. Close and seal the plastic bag. Remove from the 55-gallon drum and properly dispose of the bag in accordance with local requirements for the materials being collected.
5. Insert a new plastic bag into the 55-gallon drum as well as the existing plastic liner.
6. Position the 55-gallon drum under the drum cover.
7. Draw the open end of the bag around the drum cover and through the drum cover clamp assembly. The bag will now be outside the drum cover but inside the drum cover clamp assembly.
8. Slide the open end of the bag around the collar adapter, which is located under the slide gate. Use the buckle strap to securely fasten the bag to the collar adapter.
9. Position the drum cover carefully on top of the 55-gallon drum.
10. Secure the 4 clamps of the drum cover clamp assembly to the drum by tightening the knobs. Make sure the clamps engage the top rim of the 55-gallon drum.

Inlet and Hi Flo Inlet Plenum

1. Remove the collector's shipping cover plate. Remove excess sealant from opening.
2. Apply 1/4-in sealant around the opening toward the inside edge of the bolt pattern.
3. Align the holes on the inlet collar with the holes in the collector and secure using 3/8-16 x 1-in bolts and flat washers supplied.

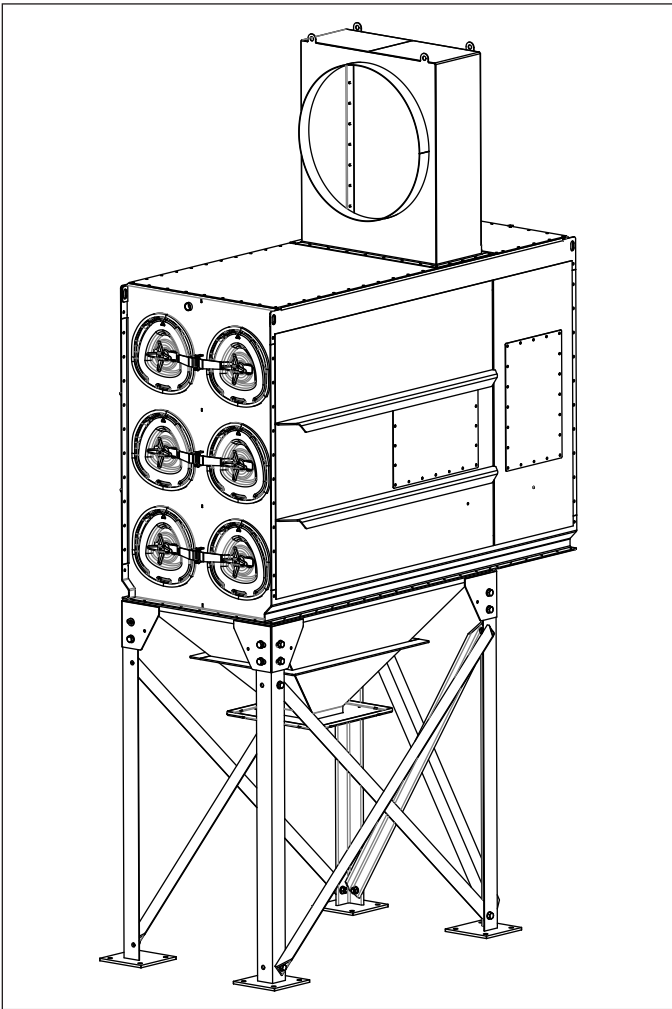

Inlet Plenum

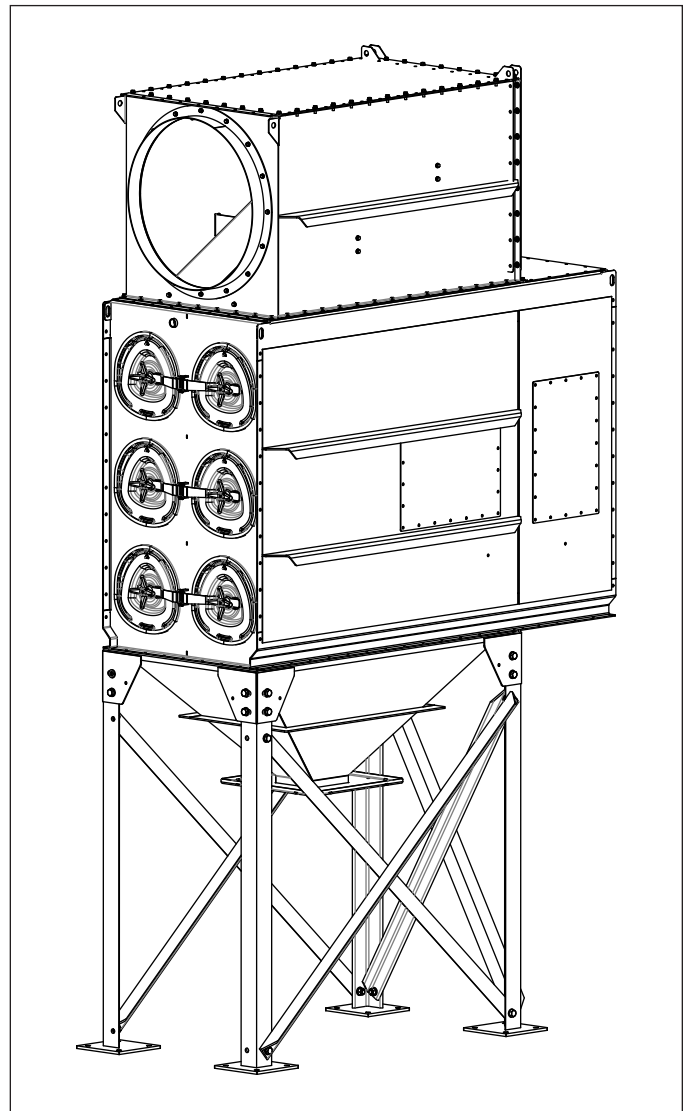

High Flo Inlet Plenum

Extended Dirty-Air Plenum

The extended dirty-air plenum is used in applications requiring an air management module or when a single inlet serves multiple modules.

The extended dirty-air plenum is supplied with standard service access panels on the sides and top of the plenum.

The top access panel is available with and without an explosion vent.

Air Management Module

The air management module is used in applications involving heavy grain loading, large or abrasive particles in the airstream, or in applications when a collector with a single inlet serves multiple modules. It is equipped with a louvered panel near the bottom, which prevents re-entrainment of the dust that falls through to the hopper. This module does not contain filters, and is available for use with an extended dirty-air plenum only.

Air management modules are supplied with a standard 36 x 24-in and 36 x 16-in covered opening on front of the collector.

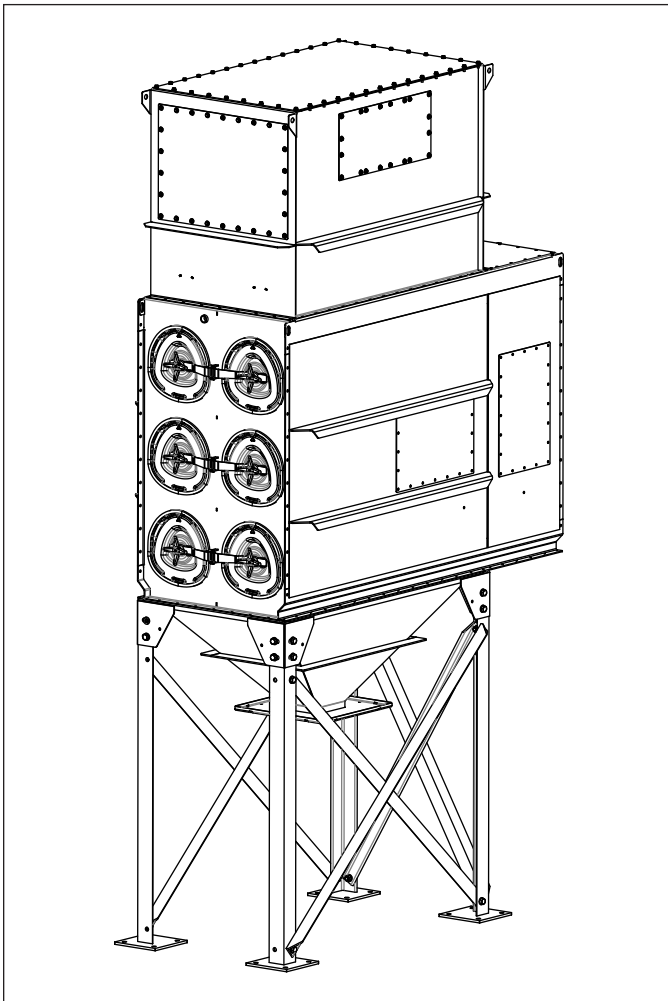

Extended Dirty-Air Plenum

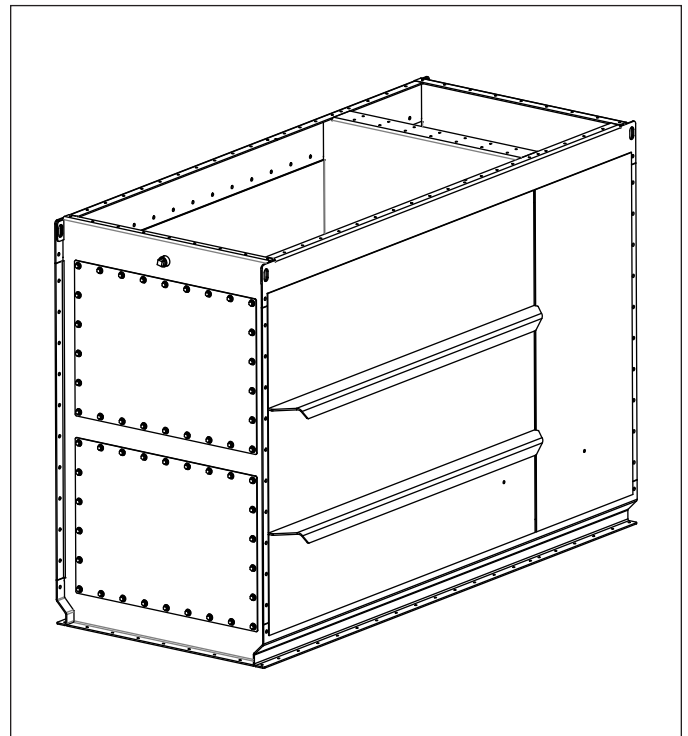

Air Management Module

Cold Climate Kit



Electrical installation, service, or maintenance work must be performed by a qualified electrician and comply with all applicable national and local codes.

Turn all power off and lock out all power before performing service or maintenance work.

Do not install in classified hazardous atmospheres without an enclosure rated for the application.

1. Install the power connection kit on the heat cable following the manufacturer's instructions.
2. Start with the upper right-hand valve, wrap heat cable around the valve as shown in Detail A. Pull heat cable tight.

NOTICE

Double wrap between round coupling and square valve cover.

3. Position a 3-in hose clamp around the double wrapped heat cable and tighten securely.
4. Wrap remaining valves using the same technique in the order shown in Detail B.
5. Drill a 1-in diameter hole in the back of the junction box. See Detail C. Assemble the power connection kit following the manufacturer's instructions.
6. Secure junction box to manifold using two, 8-in hose clamps wrapped around the standoff.
7. Wrap 6-ft of pipe insulation tape around each heat-cable wrapped valve. Wrap the entire valve, double wrapping the hose-clamped heat cable. Secure with cable ties.

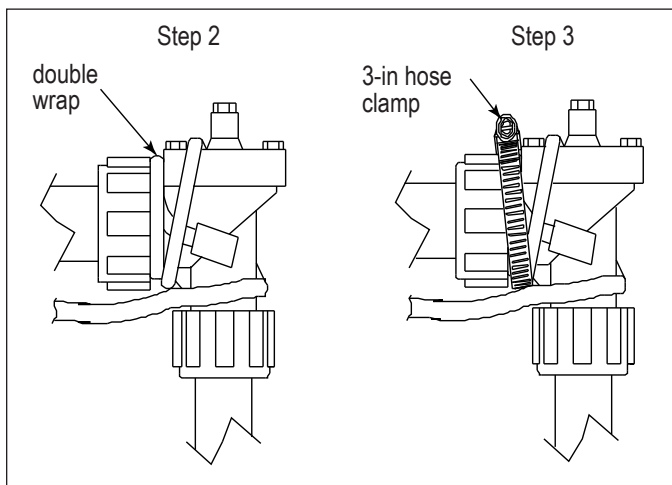

Cold Climate Kit, Detail A

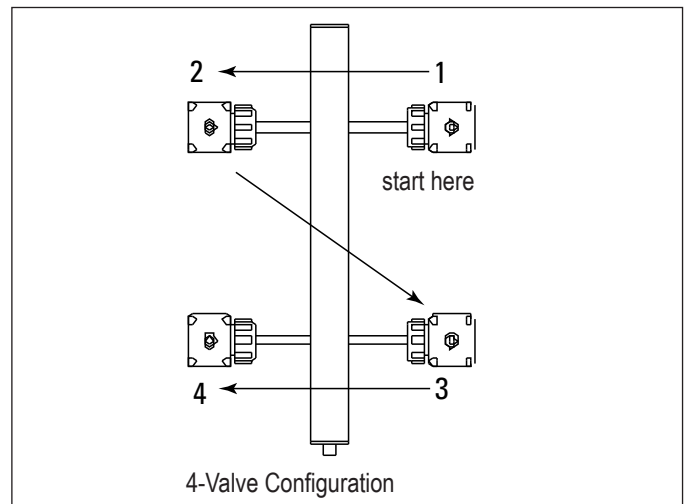

Cold Climate Kit, Detail B

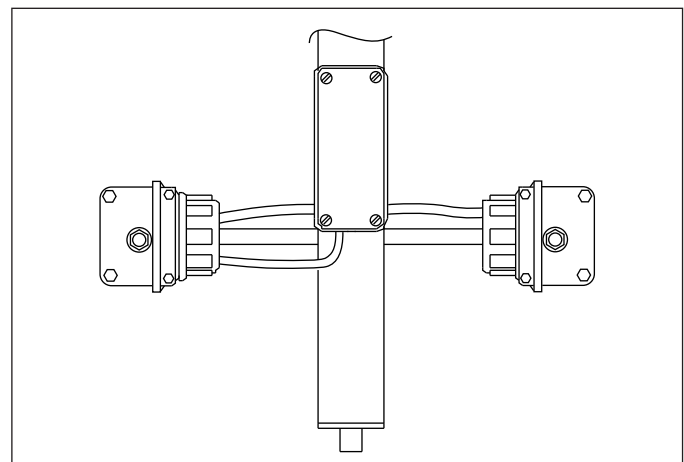

Cold Climate Kit, Detail C

Explosion Relief Panel



Personal injury, death, and/or property damage can result from material discharge during venting.

The material discharged during the venting of an explosion must be safely directed outdoors away from areas occupied by personnel to reduce risk of personal injury and/or property damage.

The risk of personal injury and/or property damage can be minimized or avoided by locating vented equipment outside buildings and away from normally occupied areas.

Explosion relief panels should be inspected regularly to confirm physical and operational condition. Replace any damaged parts immediately.

Standard explosion relief panels are intended for outdoor installations only.

Unless otherwise noted, the explosion venting calculations are based on formulas from NFPA-68 for outdoor applications only, with no duct or obstructions on the explosion vent panel.

Contact Donaldson Torit for assistance in calculating specific venting requirements for equipment.

NFPA 68 can provide guidance on both the frequency of and appropriate details for inspections.

Sprinkler Coupling



Sprinklers can place a large quantity of water in the dust collector when activated. Provide adequate drainage to remove water. Excess water weight can cause the leg structure to collapse.

Consult with local authorities when installing fire control systems on dust collection equipment.

NOTICE

Sprinkler couplings are provided for the convenience of fire control system installers. The fire control system installer shall make their own decisions on the appropriate location of all additional fire control system components.

Start-up / Commissioning

Instruct all personnel on safe use and maintenance procedures.



Electrical installation, service, or maintenance work must be performed by a qualified electrician and comply with all applicable national and local codes. This equipment may start or stop unexpectedly from a remote location.

Turn all power off and lock out all power before performing service or maintenance work.

Turn compressed air supply OFF, bleed and lock out lines before performing service or maintenance work.

Check that the collector is clear and free of all debris before starting.

Do not operate in classified hazardous atmospheres without an enclosure rated for the application.

Optional fans over 600 lbs must be independently supported.

1. Check all electrical connections for tightness and contact.
2. Check for proper rotation on all motors as described below.



Do not look into fan outlet to determine rotation. View the fan rotation through the back of the motor.

Check that the exhaust plenum is free of tools or debris before checking fan rotation.

Stand clear of exhaust to avoid personal injury.

Do not interchange a power lead with the ground wire. Severe personal injury and/or property damage may result.

- a. "Bump" the fan to initiate rotation.
 - b. As the fan is winding down (unpowered) compare fan rotation to the rotation label (located on fan housing) direction.
3. If the fan rotation is reversed, correct the rotation.
To reverse rotation, single-phase power supply: Follow manufacturer's instructions on the motor's nameplate.
To reverse rotation, three-phase power supply: Switch any two leads on the motor junction box.
 - a. Turn power to the collector OFF and Lock-Out all energy sources.
 - b. Within the junction box, swap the connection location of two power leads on the terminal block, making certain not to swap a power lead and the ground wire.



Do not interchange a power lead with a ground wire or severe personal injury and/or property damage may result.

4. Ensure all equipment access panels are sealed and secure.
5. Check that the dust container is properly sealed and clamped.
6. Check that fan exhaust damper is set to the fully-closed position.
7. Check and remove all loose items in or near the inlet and outlet of the collector.
8. Check that all remote controls and solenoid enclosures (if applicable) are properly wired and all service switches are in the OFF position.
9. Check that all optional accessories are installed properly and secured.
10. Turn power ON at source.
11. Turn the compressed-air supply ON. Set compressed-air supply pressure to a level suitable for the filters (90-psig).
12. Turn fan motor ON.
13. Adjust airflow with the exhaust damper.

NOTICE

Excess airflow can shorten filter life, cause electrical system failure and fan motor failure.

14. Turn powered hopper discharge material handling system components ON.
15. Turn ON remaining optional accessories.
16. Ensure any and all fire and explosion mitigation systems are engaged and armed.

Decommissioning

Once the collector has reached the end of operational life it will need to be decommissioned.



During decommissioning, there is potential for exposure to the dust in the collector. Most dusts present safety and health hazards that require precautions. Wear eye, respiratory, head, and other protection equipment suitable for the type of dust when performing any decommissioning activities.

LOCK-OUT all energy sources prior to performing any decommissioning activities on the equipment.

Electrical service must be performed by a qualified electrician.

Disconnection of ducts must be performed by a qualified contractor.

1. Lock-out all energy sources to the collector, material handling system and other associated equipment.
2. Remove all filters from the collector and dispose of in a suitable fashion for the dust in the collector. (See Filter Replacement for removal instructions).
3. Disconnect electrical power from the collector and material handling system components and remove any associated conduit or hardware from the exterior of the collector.
4. Clear residual dust accumulations from surfaces inside the collector and associated components in a fashion suitable for the dust, prior to further disassembly.
5. Remove and dispose of all material handling components from the collector hopper discharge.
6. Disconnect all ducts from the collector.
7. Once all cross bracing has been taken down, remove anchor bolts and lower leg pack columns.
8. Secure all collector components to a suitable transport carrier and transport to a disposal site suitable for the dust in the collector.

Appendix B - Clean Change Bag-In/Bag-Out Filter and Liner System

Disclaimer

Clean Change components for filter and hopper discharge are not standard products. This section is only applicable to collectors originally sold with Clean Change components.

Clean Change Bag-In/Bag-Out Filter and Liner System

The Clean Change Filter and Liner System is designed for dust containment. Each cartridge collector may include Bag-In/Bag-Out (BIBO) collars, clamps, bands and bags for the filters and/or containment options for the cartridges and/or hopper. Hopper options may include a single or double inflatable valve and/or 50-ft continuous containment liner for discharge. Contact your Donaldson Torit representative for additional information on custom collector options.



Use extreme caution when changing bags in hazardous material applications.

Wear appropriate PPE including appropriate protective clothing and respirator, to prevent accidental exposure to hazardous material.

When properly used, the Bag-In/Bag-Out Option reduces exposure to contaminants and exposure of contaminants to the atmosphere.

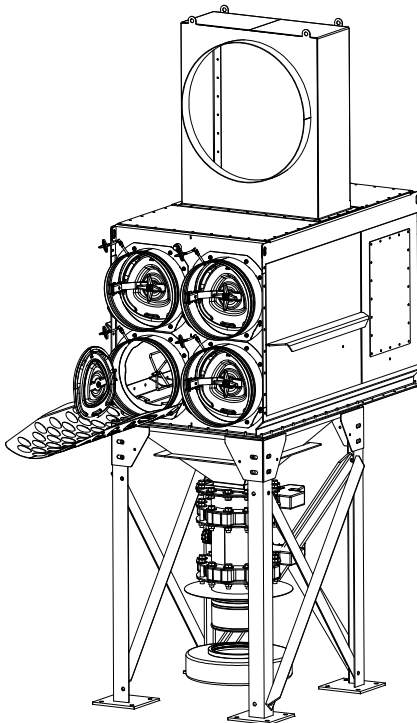

Typical Clean Change Filter and Liner System

Continuous Liner Collar Installation

The Continuous Liner Collar should be installed after a discharge device such as a double dump valve or airlock. A transition flange may be needed to connect the components. The Continuous Liner Collar is not preinstalled to the collector and may need to be securely fastened to the transition chosen for your specific application.

1. Remove all packaging from the continuous collar.
2. Place gasket on collar flange and align Liner Collar with transition flange.
3. Fasten the collar to the transition flange using bolts, washers and nuts.
4. Tighten hardware alternately in steps.

Clean Change Liner Pack Change-Out Procedure

The Donaldson Clean Change Liner System provides a contained approach for the off-loading of powders from the Donaldson Torit Dust Collector. An advantage of the continuous liner system is being able to replace follow-on packs without breaking powder containment for continuous production.

The continuous liner design eliminates cross contamination of powders. The pre-packaged 50-ft liners reduce labor by allowing operators to continuously process powders, instead of stopping production to discharge the hopper.

The liner system attaches directly to the collector discharge device via the continuous liner collar. Liner bands and clamps are used to secure the 50-ft liner. Each 50-ft liner provides the equivalent of ten 50 gallon (185 liter) drums in capacity. It is up to the end-user to determine how often to discharge and dispose of the powder.

Clean Change Liner System Components

Initial purchase of Donaldson Clean Change Solution includes:

- 2 - Dual Posi-Flate Valves (controls optional)
- 1 - 50-ft continuous liner pack with two integrated rubber gaskets
- 1 - Liner Pack Shroud
- 1 - Metal Band Clamp
- 1 - Locking Outer Clamp (with integrated rubber gasket)
- 1 - Crimping Tool with 100 crimp ties
- 1 - Cutting Tool

Clean Change Liner System Installation

The Clean Change Liner system should be attached after installation of the Donaldson Dust Collector and before beginning dust collection from the process.

Note: It is recommended that the Donaldson Torit Dust Collector be completely installed before attaching the Clean Change Liner System.

Step by step liner instructions are provided in the ILC Dover Document Number DOC9261 provided separately.

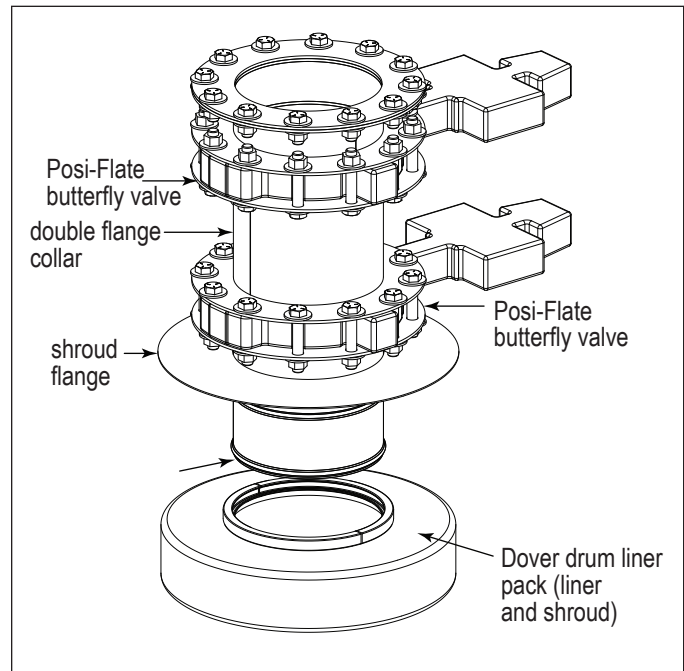

Clean Change BIBO



Most dusts present safety and health hazards that require precautions. Wear eye, respiratory, head and other protection equipment suitable for the type of dust.

Use proper safety and protective equipment when removing contaminants and filters.

Dirty filters may be heavier than they appear. Use appropriate equipment to access filters and appropriate lifting methods to avoid personal injury and/ or property damage.

Turn all power OFF and lock out all power before performing service or maintenance work.

Turn compressed air supply OFF, bleed and lock out lines before performing service or maintenance work.

Do not operate with missing or damaged filters.

All filters must be removed and installed utilizing the following BIBO procedure to maintain containment.

BIBO Components

The following are located in each filter access port to facilitate Bag-In/Bag-Out (BIBO) replacement of the filter:

- Hinged BIBO Cover - provides a safety barrier to contain BIBO bag inside the access port.
- BIBO Bag - safely contains contaminants collected from the filter cartridge in each access port.
- Band Clamp - secures the BIBO bag and O-ring to the collar.
- O-ring gaskets (front and back) - creates a seal around the BIBO bag to secure the bag to the collector.
- Breather Filter Assembly - provides a filtered exhaust for removal of air as the BIBO bag is compressed and stored in the BIBO collar.
- BIBO Support Shelf - provides support to the filter during filter replacement and holds hinged BIBO cover out of the way for filter change.

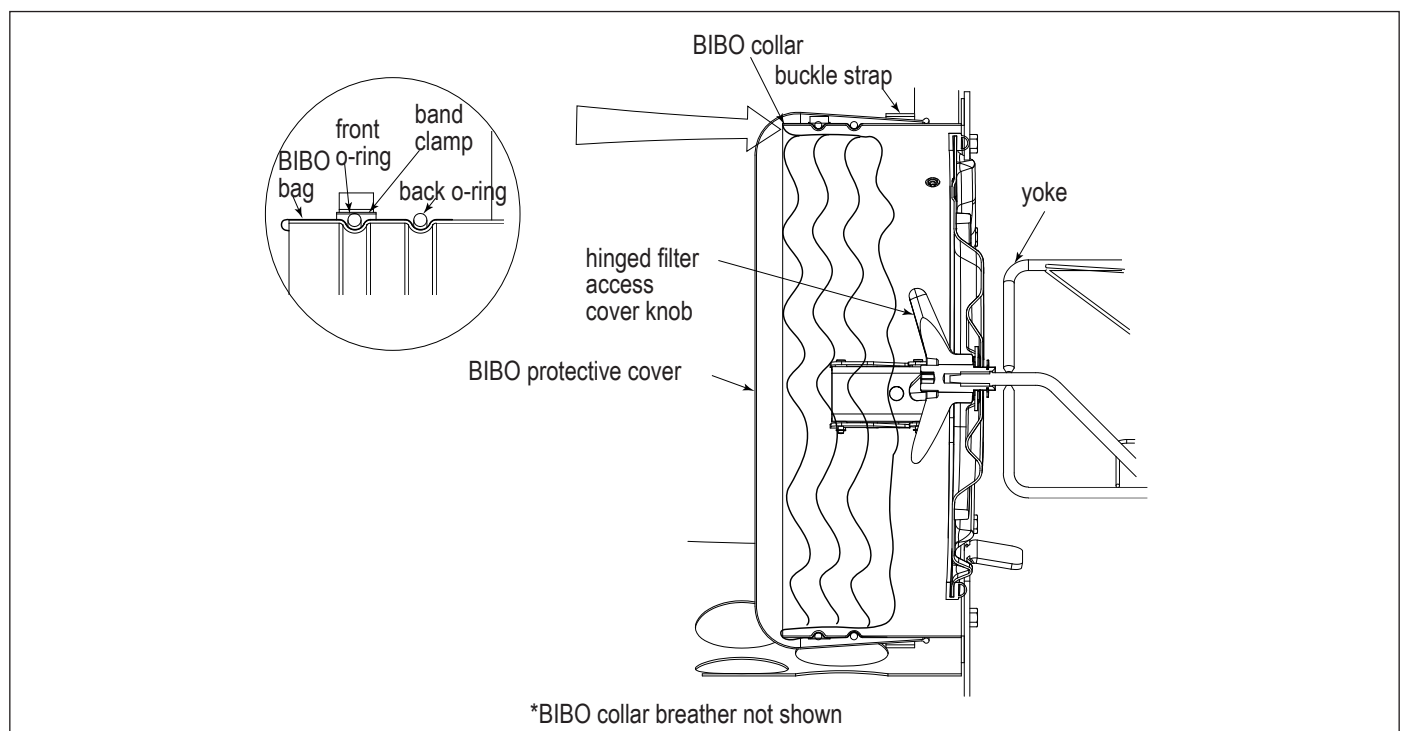

BIBO Components (Side View)

Pre-Installation - Filters, BIBO Bags and BIBO Collar Breather

NOTICE

If filters, Bag-In/Bag-Out (BIBO) bags and BIBO Collar Breathers are not pre-installed, please follow these steps per opening, before the collector is turned on.

1. Unbox necessary number of cartridge filters per model capacity.
2. Open hinged access cover and install filters, gasket end first under Filter Replacement section of the DFE Installation and Operation Manual.
3. Close and seal filter access cover on collector.
4. Locate BIBO Collar Filter Breather and attach to BIBO Collar.
5. On each collar, place the BIBO bag around the BIBO collar with the integrated O-ring gasket in the back groove (closest to collector) of the collar creating the first seal between the bag and collar. If the Clean Change bag is used, place the bag extension on the opposite side of the access cover hinge to allow for easy access to the filter opening.
6. Place separate (unattached) O-ring gasket in the first groove (furthest from collector) of the collar. This will give two levels of containment between collar and bag.
7. Take open steel band camp, place around the collar and tighten around the integrated gasket (first gasket installed) creating the triple seal for filter change-out containment.
8. With BIBO bag now properly attached to BIBO collar, slowly roll empty bag into collar so that air will disperse through filter breather. Once the bag has dispersed all air it should fit inside collar up against closed filter access cover.
9. Insert BIBO protective cover onto BIBO collar to protect and hold BIBO bag in place. Place buckle strap around the protective cover and tighten to secure protective cover.
10. If hopper discharge is also installed and connected, turn the collector ON.

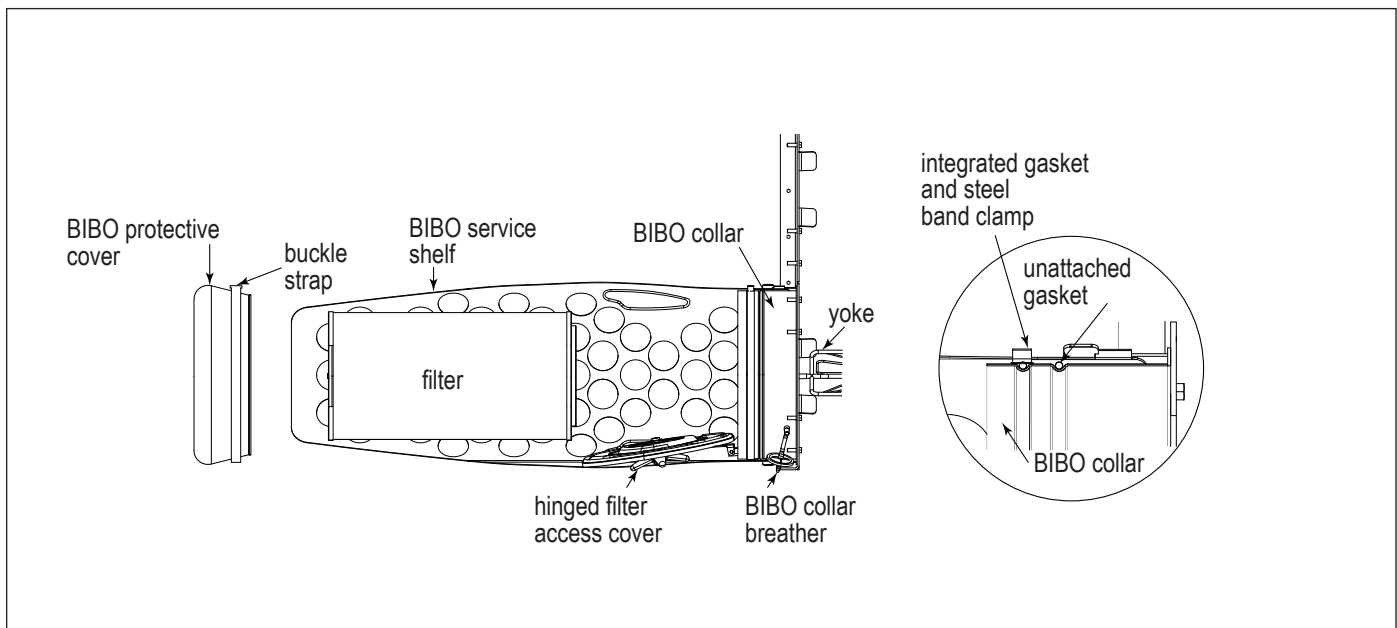

Initial Filter Installation of BIBO

Filter Replacement



Most dusts present safety and health hazards that require precautions. Wear eye, respiratory, head and other protection equipment suitable for the type of dust.

Use proper safety and protective equipment when removing contaminants and filters.

Dirty filters may be heavier than they appear. Use appropriate equipment to access filters and appropriate lifting methods to avoid personal injury and/ or property damage.

Turn all power OFF and lock out all power before performing service or maintenance work.

Turn compressed air supply OFF, bleed and lock out lines before performing service or maintenance work.

Do not operate with missing or damaged filters.

Ensure all pre-installed items are present, undamaged and in the correct place before proceeding with filter replacement. See BIBO Components. Failure to comply may result in containment failure and lead to property damage and/or personal injury.

Clean Change

1. Turn all power to the collector OFF.
2. Starting at the top row of filters, securely position the BIBO service shelf on the bracket attached to the BIBO collar.
3. Remove the buckle strap and BIBO protective cover from the collar and set aside.
4. Unroll the BIBO bag from inside of the collar out onto the service shelf.
5. Toward the edge of the BIBO bag is the bag extension to be used as a glove. Using the extension as a glove reach into the bag and open the hinged filter access cover by loosening the knob. Place the filter access cover into the opening on the BIBO service shelf to hold it securely out of the way during filter change operations.
6. To remove the filter, using both hands, position the end of the bag into the filter opening and pull the filter cartridge out to the end of the bag, resting the bag and cartridge on the end of the shelf.

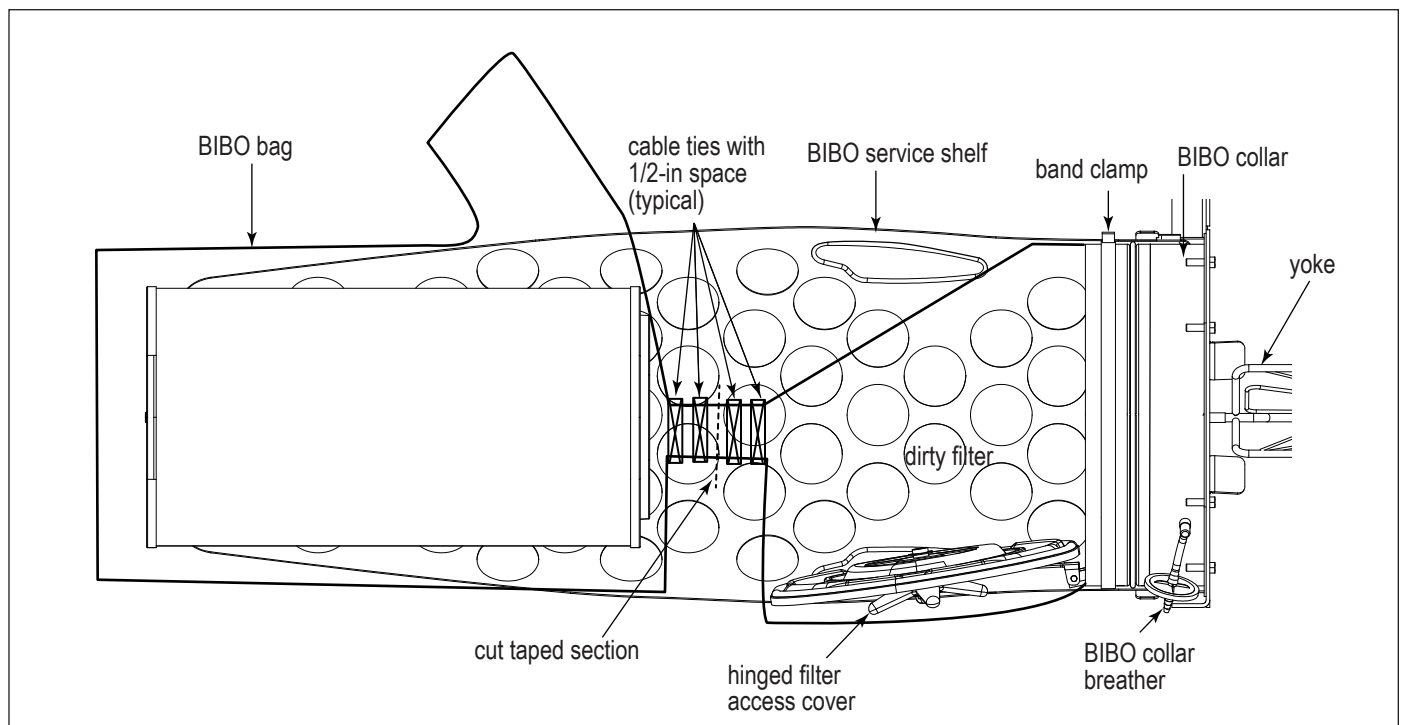

Filter Replacement

7. Loosely reposition the access cover to the end of the filter yoke.
8. Locate the cleanest section of bag closest to the collar, making sure there is enough bag to collapse into a tight bundle without stretching the bag too tight.
9. Wrap and hand tighten two cable ties around the collapsed bag section between the collar and filter cartridge, spacing the cable ties approximately 1/2-in apart.
10. Compress as much air as possible from the BIBO bag and BIBO bag extension.
11. Securely tighten the two cable ties with the supplied cable tie tool at the maximum setting.
12. Cut the compressed BIBO bag between the two cable ties leaving one tie around each section.
13. Place tape over the cut end of the BIBO bag containing the filter and both cable ties.
14. Securely wrap tape around the cut end of the bag covering a minimum of 3-inches around the bag end.
15. Repeat steps 2-14 for all filter rows containing one filter per opening. If collector contains two filters per opening, proceed to Step 17.
16. Properly dispose of the BIBO bag containing the filter and proceed to Step 24.
17. For collectors containing two filters per opening, gently push the stub into the collar.
18. Open a new bag and place the open end around the bag collar as close to the collector as possible. The bag stub is now inside the new bag.
19. Loosen the safety strap, slide the new bag under the strap, and the bag stub toward the end of the collar. Tighten the safety strap to hold the new bag only and carefully remove the bag stub from the collar.
20. Use the filter ejector rod to pull the second filter toward the bag collar until the filter is within reach. Repeat steps 2-23 for all filter rows.
21. Carefully remove the band clamp from the collar.

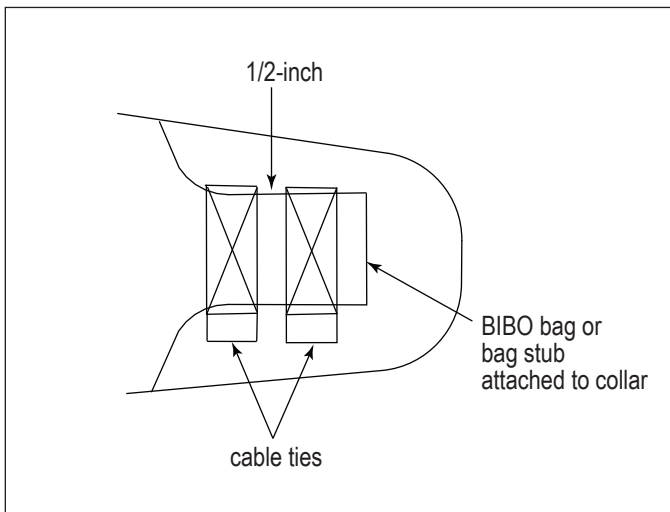

Tape Wrap (Steps 10-13)

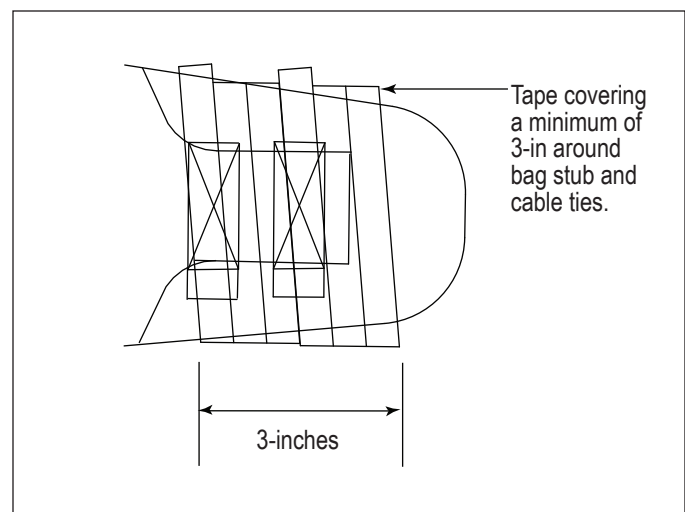

Tape Wrap (Steps 15-17)

22. Move the front (integrated) O-ring gasket back 1/4-in in front of the back (unattached) O-ring gasket.



Do not remove bag from collar. Failure to comply will result in containment exposure.

23. Slowly and carefully slide the bag and both O-ring gaskets towards the front of the collar until the back o-ring gasket engages the front collar groove (furthest from collector) illustrated below.
24. Place a clean filter cartridge in a new BIBO bag with the filter gasket side facing the bag opening toward the collar on the collector.

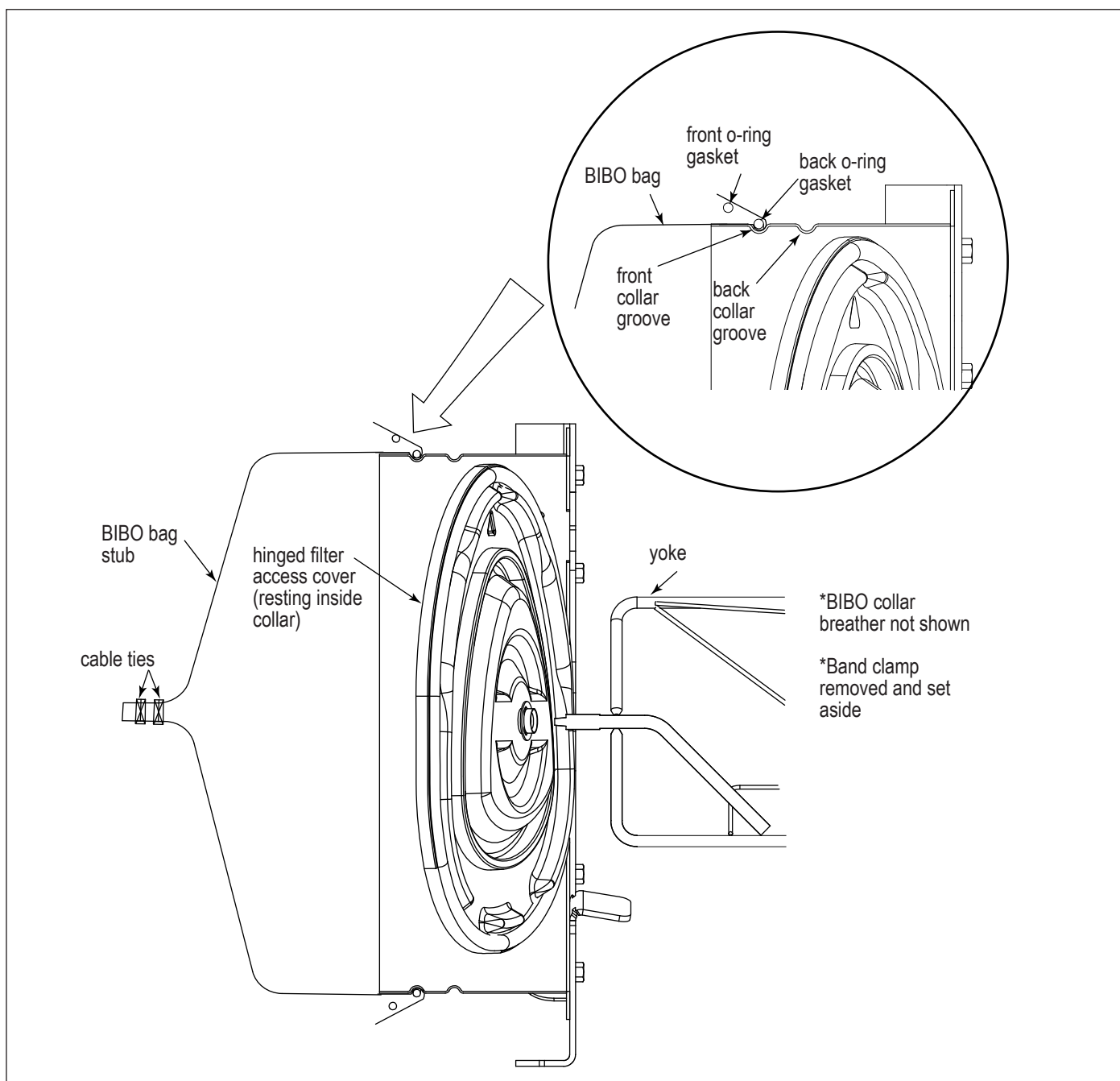

Bag Stub Repositioning (Side View)

25. Place clean filter and BIBO bag on BIBO service shelf.
26. Slide the new BIBO bag over the collar and past the bag stub and bag stub O-ring gasket. Position the bag extension on the opposite side of the access cover hinge
27. Install the new front (integrated) O-ring gasket in the back groove.
28. Install the back (unattached) O-ring gasket adjacent to the back O-ring gasket.
29. Reinstall the band clamp on the front O-ring gasket (closest to collector).
30. Invert the BIBO bag extension with both hands and pull off the bag stub section and O-ring gaskets into the new BIBO bag. O-ring gaskets will automatically pull off with it.
31. Move the back O-ring gasket into the front groove.

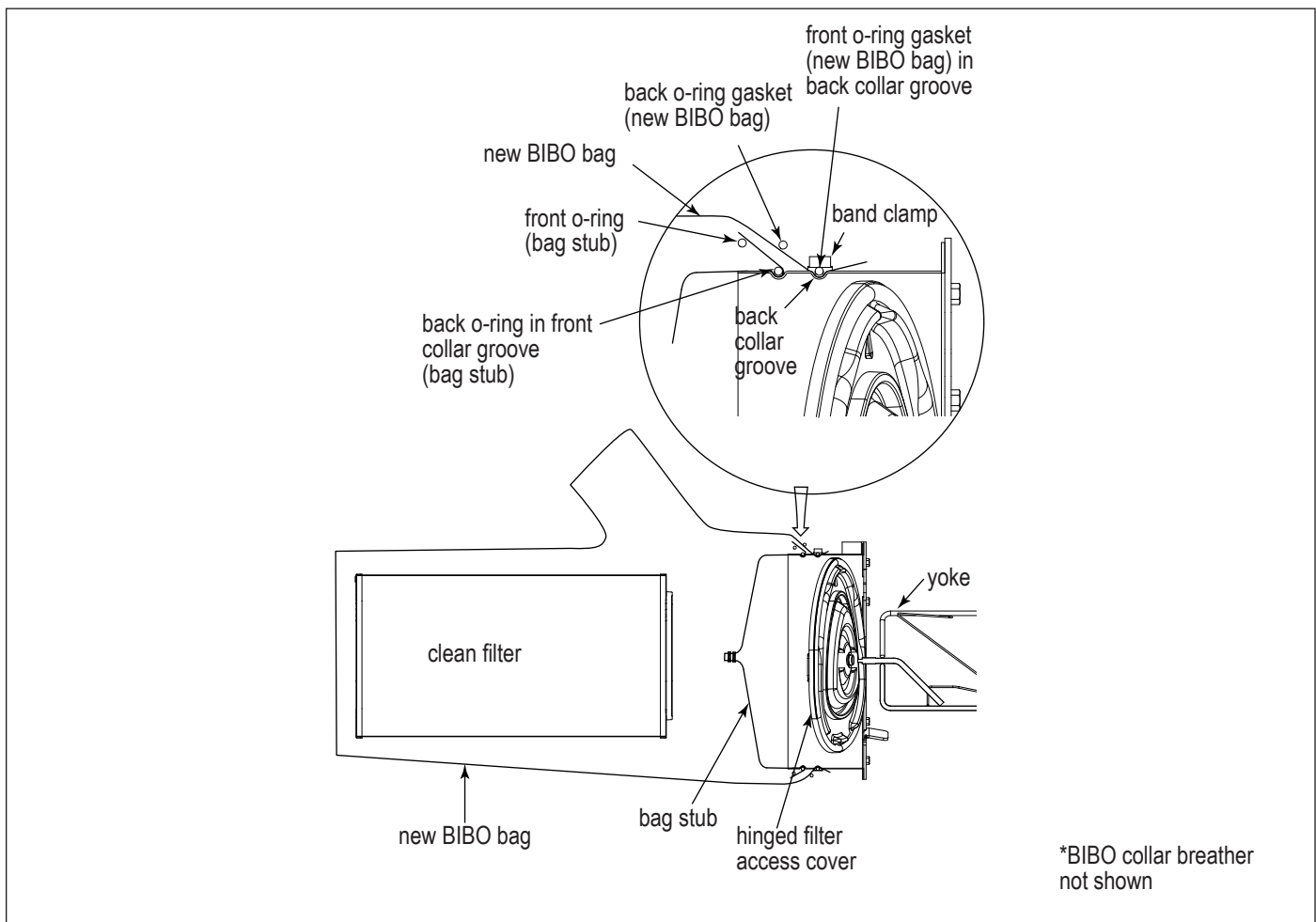

Clean Change Filter Replacement

32. Remove the band clamp and reinstall on the back O-ring gasket.
33. Install the filter with gasket end toward collector.

Using the BIBO bag as a glove, support the filter with both hands while positioning the alignment features and slide the gasket end of the new filter onto the end of the suspension yoke.



Do not allow the bag to become pinched between the access cover and sealing surfaces. Failure to comply may result in containment failure.

NOTICE

The filter shape and yoke work together to ensure proper filter alignment during filter installation. To assist with alignment, an alignment mark (\triangle) at the top of the filter endcap (non-gasketed end) must match with the alignment mark (∇) at the top of the filter access opening.

If knob fails to thread onto yoke, on the opposite side of the hinge, apply slight pressure to the access cover using other hand. Continue to turn knob to start threading onto the yoke.

34. Close the filter access cover and tighten onto the yoke.
35. Slowly roll bag back into the collar to allow air to escape through the BIBO collar breather (see Bag Setup).
36. Install the BIBO protective cover and secure with buckle strap.
37. Turn electrical power and compressed air supply ON before starting collector.

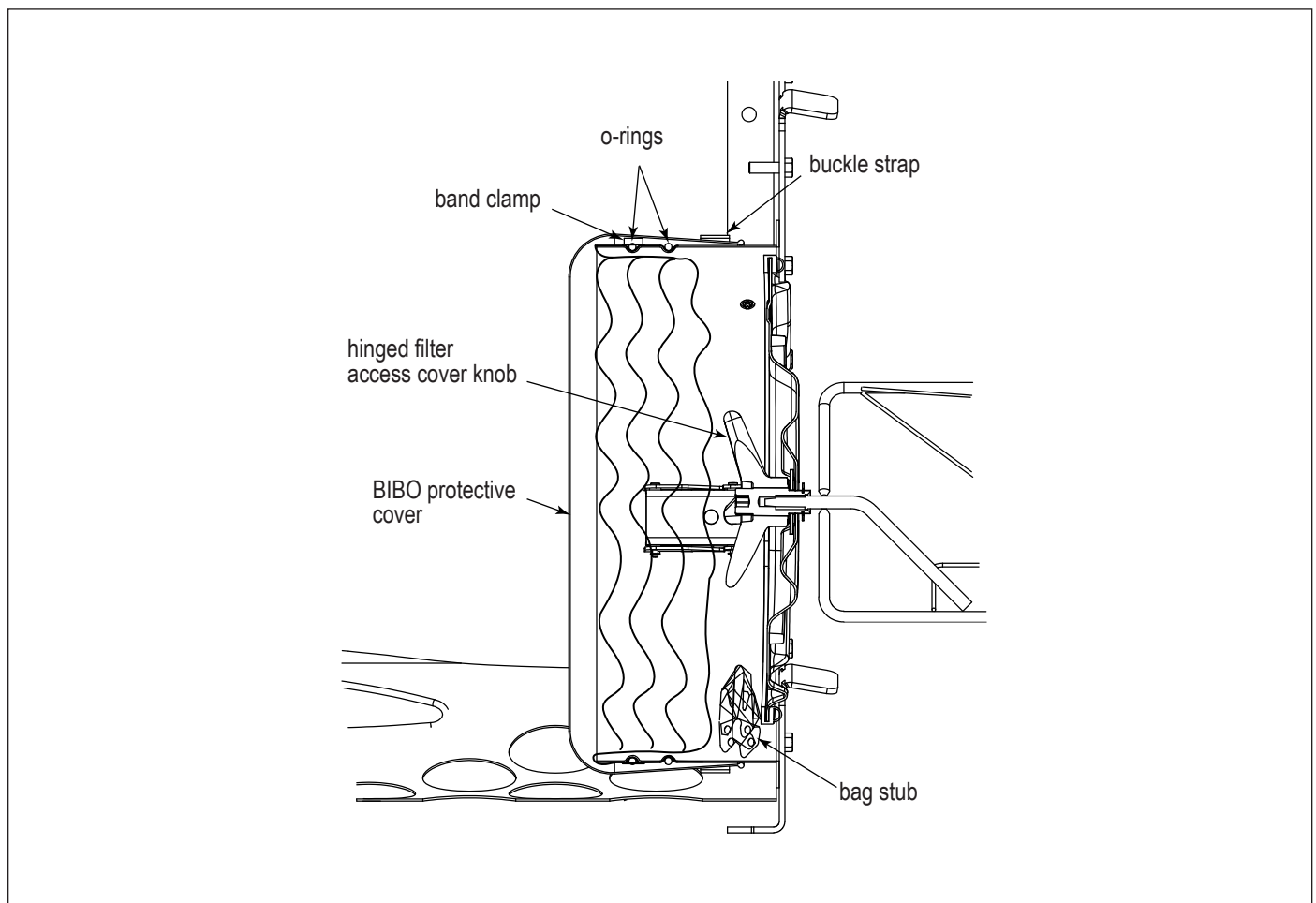

Bag Setup (Side View)

BIBO Collar Breather

The BIBO collar breather provides a means for the air to escape during bag compression into the collar without breaking containment. Use the following procedure if replacement of the breather filter should become necessary.

1. Press on the metal trigger to release the breather filter and disconnect the assembly.
2. Remove and properly dispose of the breather filter.
3. Insert new breather filter in the female quick disconnect ensuring it is securely installed.

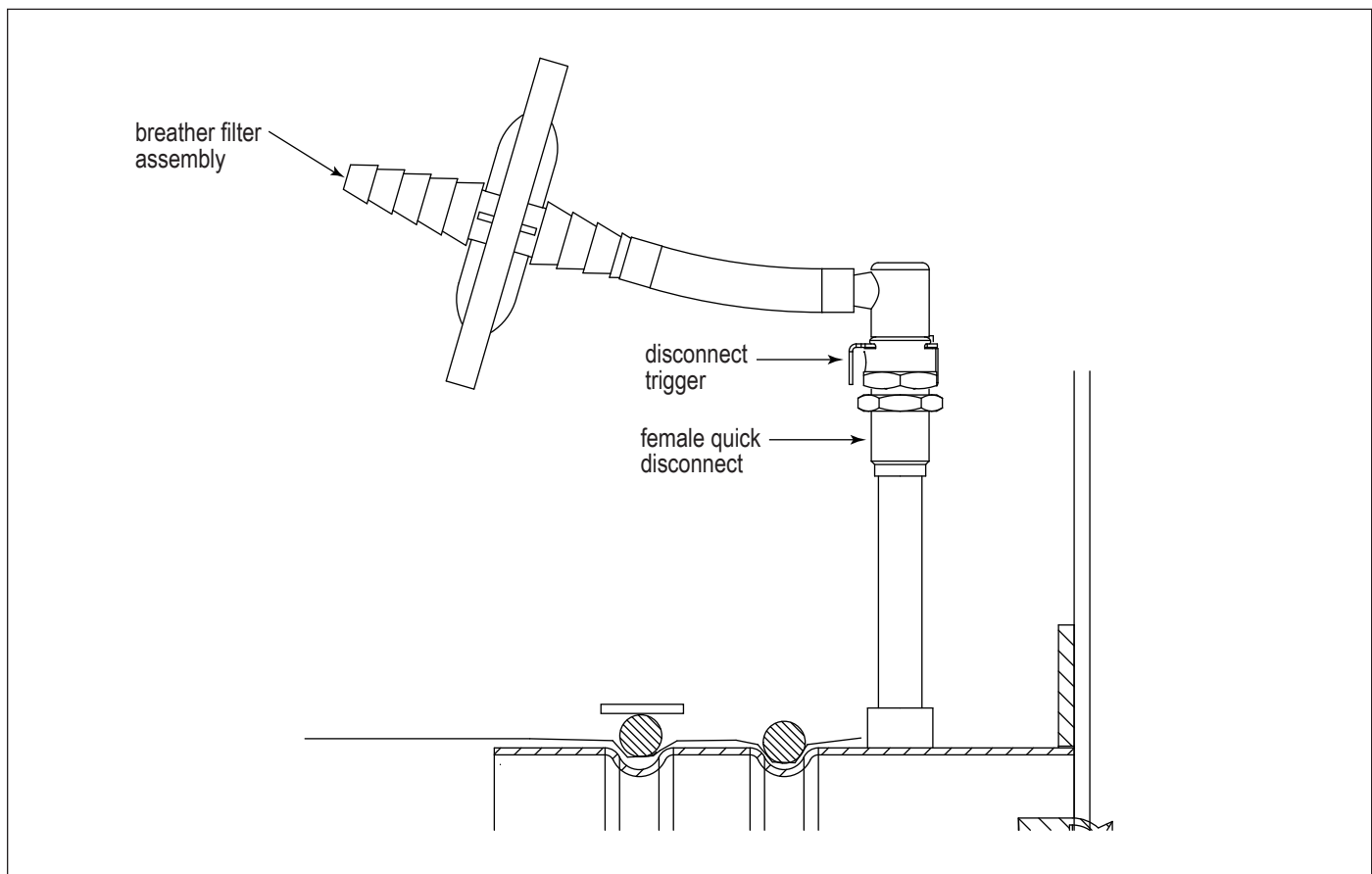

BIBO Collar Breather

Bag-Out

Bag out collars are available for capturing nuisance, non-hazardous dust that may fall from dirty filters during the filter change.

Note: This is not for contamination prevention or full containment purposes and is not a substitute for BIBO. Contact Donaldson Torit for selection assistance.

1. Turn all power to the collector OFF.
2. Begin filter replacement at one of the top filter access ports. Continue by replacing the remaining filters in the top row. Proceed to replace the filters in the next row. Replacing the filters row by row starting at the top will help limit dusting during replacement.
3. Remove access cover by turning knob counterclockwise.



Do not use the access cover features as climbing equipment.

4. Break the seal between the filter cartridge and the sealing surface.
5. Place the bag out bag around collar surrounding port hole. Starting from the bottom of the collar, roll the bag opening over the edge of the collar. With both hands, move around the collar until the bag is in position all the way around the collar. Secure bag on collar with buckle strap.
6. Using the bag as a glove, pull the filter into the bag.
7. Remove the buckle strap securing the bag. Place it aside for use on the next bag. Support filter and bag when removing to prevent dust spilling. Properly dispose of bag with the filter inside of it.
8. Repeat steps 5-7 for second filter on suspension yoke.
9. Inspect and clean the sealing surface if necessary.

NOTICE

Clean dust from gasket dealing area to ensure a positive filter gasket seal.

10. Clean any dust from the yoke threads that may have accumulated during the filter removal.
11. Check for an accumulation of dust in the storage area and empty as necessary.
12. Follow filter installation instructions found in the Filter Replacement section of this manual.

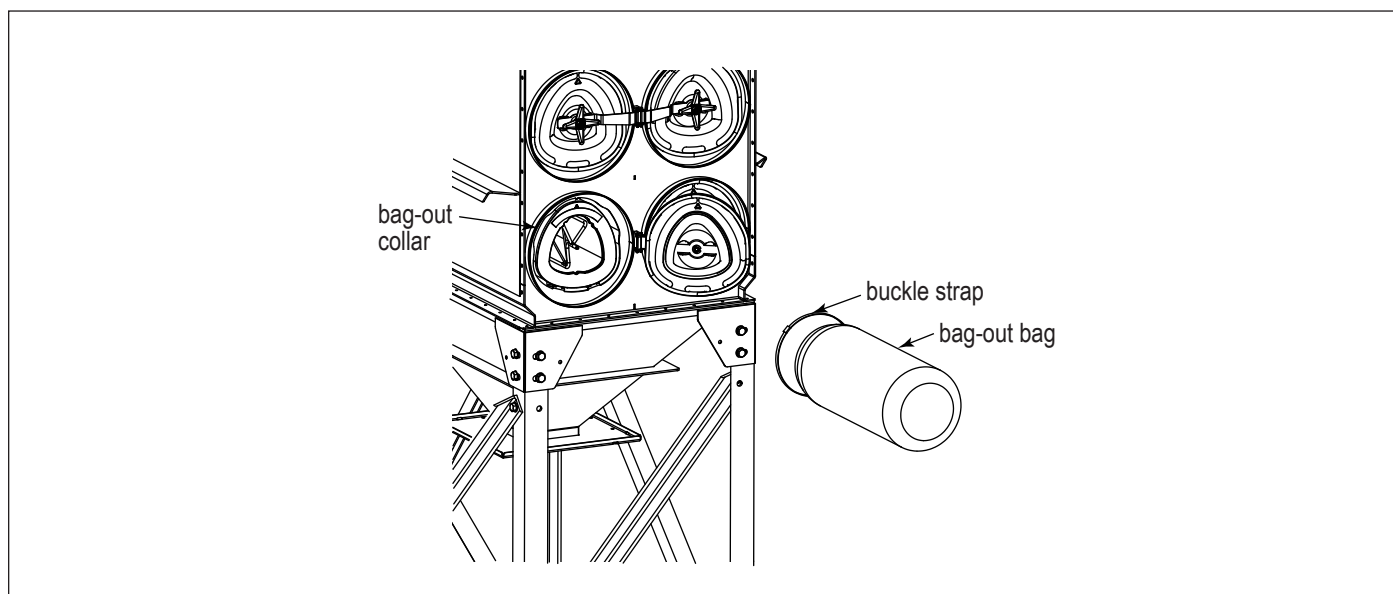

Bag-Out

Product Information

(Process Owner to complete and retain for your records)

| | |
|----------------------------|--------------------------------|
| Model Number _____ | Serial Number _____ |
| Ship Date _____ | Installation Date _____ |
| Filter Type _____ | |
| Collected Dust _____ | |
| Dust Properties: Kst _____ | Pmax _____ MIE _____ MEC _____ |
| Accessories _____ | |
| Other _____ | |
| _____ | |

Donaldson Industrial Air Filtration Warranty

Donaldson warrants to the original purchaser only that the Goods will be free from defects in material and manufacture for the applicable time periods stated below: (1) Major structural components for a period of ten (10) years from the date of shipment; (2) Non-Structural, Donaldson-built components and accessories including Donaldson Airlocks, TBI Fans, TRB Fans, Fume Collector products, Donaldson built electrical control components, and Donaldson-built Afterfilter housings for a period of twelve (12) months from date of shipment; and (3) Donaldson-built filter elements for a period of eighteen (18) months from date of shipment.

Buyer is solely responsible for determining if goods fit Buyer's particular purpose and are suitable for Buyer's process and application. Seller's statements, engineering and technical information, and recommendations are provided for the Buyer's convenience and the accuracy or completeness thereof is not warranted. If, after Seller receives written notice, within the warranty period, that any goods allegedly do not meet Seller's warranty, and Seller, in its sole discretion, determines that such claim is valid, Seller's sole obligation and Buyer's exclusive remedy for breach of the foregoing warranty or any Seller published warranty, will be, at Seller's option, either: (i) repair or replacement of such goods or (ii) credit or refund to Buyer for the purchase price from Seller. In the case of repair or replacement, Seller will be responsible for the cost of shipping the parts but not for labor to remove, repair, replace or reinstall the allegedly defective goods. Refurbished goods may be used to repair or replace the goods and the warranty on such repaired or replaced goods shall be the balance of the warranty remaining on the goods which were repaired or replaced. Any repair or rework made by anyone other than Seller is not permitted without prior written authorization by Seller, and voids the warranty set forth herein. Seller warrants to Buyer that it will perform services in accordance with the Sales Documents using personnel of required skill, experience and qualifications and in a professional and workmanlike manner in accordance with generally recognized industry standards for similar services. With respect to any services subject to a claim under the warranty set forth above, Seller shall, in its sole discretion, (i) repair or re-perform the applicable services or (ii) credit or refund the price of such services at the pro rata contract rate and such shall be Seller's sole obligation and the exclusive remedy for breach of the foregoing warranty on services. Products manufactured by a third party ("Third Party Product") may constitute, contain, be contained in, incorporated into, attached to or packaged together with, the goods. Buyer agrees that: (a) Third Party Products are excluded from Seller's warranty in this Section 7 and carry only the warranty extended by the original manufacturer, and (b) Seller's liability in all cases is limited to goods of Seller's design and manufacture only. EXCEPT FOR SELLER'S WARRANTY OF TITLE TO THE GOODS, SELLER EXPRESSLY DISCLAIMS AND EXCLUDES ALL OTHER WARRANTIES WHATSOEVER, WHETHER, EXPRESSED OR IMPLIED, ORAL, STATUTORY, OR OTHERWISE, INCLUDING BUT NOT LIMITED TO MERCHANTABILITY, FITNESS FOR A PARTICULAR PURPOSE, NON-INFRINGEMENT OF THIRD PARTY INTELLECTUAL PROPERTY AND ANY WARRANTIES ARISING FROM TECHNICAL ADVICE OR RECOMMENDATIONS, COURSE OF DEALING OR OF PERFORMANCE, CUSTOM OR USAGE OF TRADE. Seller's obligations do not cover normal wear and tear or deterioration, defects in or damage to any goods resulting from improper installation, accident or any utilization, maintenance, repair or modification of the goods, or any use that is inconsistent with Seller's instructions as to the storage, installation, commissioning or use of the goods or the designed capabilities of the goods or that, in its sole judgment, the performance or reliability thereof is adversely affected thereby, or which is subjected to abuse, mishandling, misuse or neglect or any damage caused by connections, interfacing or use in unforeseen or unintended environments or any other cause not the sole fault of Seller, and shall be at Buyer's expense. Seller's warranty is contingent upon the accuracy of all information provided by Buyer. Any changes to or inaccuracies in any information or data provided by Buyer voids this warranty. Seller does not warrant that the operation of the goods will be uninterrupted or error-free, that the functions of the goods will meet Buyer's or its customer's requirements unless specifically agreed to, or that the goods will operate in combination with other products selected by Buyer or Buyer's customer for its use.

The terms of this warranty may only be modified by a special warranty document signed by a Director, General Manager or Vice President of Donaldson. To ensure proper operational performance of your equipment, use only genuine Donaldson replacement parts.

This Product is provided subject to and conditioned upon Donaldson's Terms of Sale ("Terms"), a current copy of which is located at termsofsale.donaldson.com. These Terms are incorporated herein by reference. By purchasing or using this Product, the user accepts these Terms. The Terms are available on our website or by calling our customer service line at 1-800-365-1331.

Donaldson's comprehensive dust collection solutions help process owners effectively address their dust, fume, and mist collection challenges by providing knowledgeable guidance, industry-leading equipment as well as unrivaled aftermarket service and support.



Donaldson.

Donaldson Company, Inc.
Minneapolis, MN

donaldson.com • shop.donaldson.com

North America

Email: donaldsontorlit@donaldson.com
Phone: (USA): +1-800-365-1331

Latinoamerica

Phone: +52-449-300-2442
Email: industrialair@donaldson.com
Toll Free: (CO) (57) 601-580-1611
(CL) +800-914-544 • (PE) +800-712-10
(BR) +55 (11) 99707-6689

China

Email: info.cn@donaldson.com
Phone: +86-400-921-7956

Donaldson Europe B.V.

Email: IAF-europe@donaldson.com
Phone: +32-16-38-3811

India

Email: info.difs@donaldson.com
Phone: +91-124-4807-400 • +18001035018

Australasia

Email: marketing.australia@donaldson.com
Phone: +61-02-4350-2066
Toll Free: (AU) +1800-345-837 • (NZ) +0800-743-387

Korea

Email: contactus.kr@donaldson.com
Phone: +82-2-517-3333

South Africa

Email: SAMarketing@donaldson.com
Phone: +27-11-997-6000

Southeast Asia

Email: IAF.SEA@donaldson.com
Phone: +65-6311-7373

Japan

Email: jp-nd.ifsweb@donaldson.com
Phone: +81-42-540-4114

IMPORTANT NOTICE: Many factors beyond the control of Donaldson can affect the use and performance of Donaldson products in a particular application, including the conditions under which the product is used. Since these factors are uniquely within the user's knowledge and control, it is essential the user evaluate the products to determine whether the product is fit for the particular purpose and suitable for the user's application. All products, product specifications, availability and data are subject to change without notice, and may vary by region or country.

IOM AG8249101 ENG, Revision 6 (February 2024) ©2014 Donaldson Company, Inc. All rights reserved. Donaldson Company, Inc. reserves the right to change or discontinue any model or specification at any time and without notice.