

LP Panelized Baghouse

684LP, 780LP and 882LP

Installation, Operation and Maintenance Manual



This manual contains specific precautions related to worker safety. The hazard alert image denotes safety related instructions and warnings in this manual. DO NOT install, operate, or perform maintenance on this collector until you have read and understood the instructions, precautions and warnings contained within this manual.

IMPORTANT NOTES

This manual has been supplied to assist with the installation, operation and maintenance for the collector purchased. Please read the manual before installing, operating, or performing maintenance on the collector as it contains specific precautions for worker safety. It is the owner's responsibility to ensure that this manual is available for use by installers, operators and maintenance personnel that will be working with this collector. This manual is the property of the owner and should be left with the collector when installation has been completed. **DO NOT** operate this collector until you have read and understood the instructions and warnings located in the installation and operation manual.

For additional copies of this manual, contact Donaldson Torit.



The Safety Alert Symbol indicates a hazardous situation which, if not avoided could result in death or serious injury. Obey all safety messages following this symbol to avoid possible injury or death. The possible hazards are explained in the associated text messages.

NOTICE

NOTICE indicates a potential situation or practice which is not expected to result in personal injury, but which if not avoided, may result in damage to equipment.

Contents

IMPORTANT NOTES	i
1 Safety Communication	1
2 Product Description	3
Standard Equipment.....	3
Collector Options and Accessories.....	4
3 Operation.....	6
Reverse Air Internal Cleaning System.....	6
Typical Collector Start-Up/Shut-Down Sequence.....	6
4 Product Service	8
Filter Replacement	9
Troubleshooting	11
Appendix A - Installation	13
Installation	14
Location and Site Selection.....	14
Provisional Anchor Bolt Recommendations	14
Delivery and Inspection	14
Unloading and Positioning.....	15
LP General Assembly Sequence Overview.....	16
1. Leg Assembly.....	18
2. Tubesheet Assembly.....	19
3. Hopper Assembly.....	23
4. Tangential Inlet Assembly	26
5. Bag Section Assembly	29
6. Clean-Air Access Plenum Assembly	32
7. Clean-Air Outlet Plenum and Roof Installation	34
8. Tubesheet Installation and Support Column	37
9. Lower Plenum Access Section Attachment and Internal Cleaning Assembly	38
10. Filter Bag and Cage Installation.....	41
11. Clean-Air Outlet Plenum and Roof Section Attachment.....	42
12. Exhaust Ducting.....	44
13. Ladder/Platform Installation	44
14. Additional Ducting	46
15. Material Discharge Mechanism.....	46
16. Electrical Connections	46
17. Fire Mitigation System	46
18. Structural Connections.....	46
19. Electrical and Mechanical Connections	46
Start-Up/Commissioning Collector	47
Decommissioning Collector	49
Product Information	50
Service Notes	51
Donaldson Industrial Air Filtration Warranty	52

1

Safety Communication



Improper operation of dust collectors and/or dust control systems may contribute to conditions in a work area or facility which could result in severe personal injury, and product or property damage. All dust collection equipment should be used only for its intended purpose and should be properly selected and sized for its intended use.

Process owners have important responsibilities relating to identifying and addressing potential hazards in their processes. When the potential for handling combustible dust exists within a process the process owner should include combustion hazards in their risk management activities and should comply with applicable codes and standards related to combustible dust.

Electrical installation must be performed by a qualified electrician.

This equipment is not designed to support site ducts, piping, or electrical services. All ducts, piping, or electrical services must be adequately supported to prevent injury and/or property damage.

Site selection must account for wind, seismic zone, and other load conditions.

Equipment may reach peak sound pressure levels above 80 dB (A). Noise levels should be considered when selecting collector location.

Most dusts present safety and health hazards that require precautions. Wear eye, respiratory, head and other protection equipment suitable for the type of dust.

Some components may be heavier than they appear. Use appropriate lifting methods to avoid personal injury and/or property damage.

Combustible Dust Hazards

Among other considerations, the current NFPA standards require owners whose processes involve potentially combustible materials to have a current Dust Hazard Analysis, which can serve as the foundation for their process hazard mitigation strategy. Mitigation may include but is not limited to:

- Prevention of all ignition sources from entering any dust collection equipment.
- Selection and implementation of fire and explosion mitigation, suppression, and isolation strategies appropriate for the risks in their process.
- Development and use of work practices to maintain safe operating conditions, and to ensure combustible dust does not accumulate within their plant or process equipment.

Donaldson designs, manufactures, and sells industrial air filtration products for a wide variety of applications. Some applications may include processes or materials with inherent fire and explosion hazards. Donaldson is neither an expert nor a certified consultant in fire, spark, or explosion detection, suppression, or control. Donaldson does not provide engineering consulting services related to process or dust hazard analyses, or code and standard compliance. Complying with applicable codes and standards and managing the risks associated with the process or materials remains the responsibility of the process owner/operator. Donaldson may provide referrals to consultants, suppliers of equipment or services related to the detection and/or mitigation of sparks, fires and/or explosions, but Donaldson does not assume responsibility for any such referrals, nor does Donaldson assume any liability for the fitness of a mitigation strategy or product for a particular installation or application. The process owner's final selection of dust collectors and risk mitigation strategies should be based on the outcome of a Dust Hazard / Process Hazard Analysis performed by the process owner. Although early engagement of a dust collector supplier provides helpful insights on the availability and features of various products, process owners should consult with a combustible dust expert and/or a process safety expert before making actual product and mitigation strategy selections.

Donaldson recommends that all industrial air filtration system designs be reviewed and approved by an expert consultant who is responsible for the integrity of the system design and compliance with applicable codes and standards. It is the process owner's responsibility to understand the risks in their process and mitigate those risks in accordance with all applicable laws, regulations and standards, including those published by the NFPA. Donaldson also recommends that proper maintenance and housekeeping procedures and work practices be evaluated, developed, and followed to maintain any industrial air filtration products in safe operating condition.

Many factors beyond the control of Donaldson can affect the use and performance of Donaldson products in a particular application, including the conditions under which the product is used. Since these factors are uniquely within the user's knowledge and control, it is essential the user evaluate the Donaldson products to determine whether the product is fit for the particular purpose and suitable for the user's application. All products, product specifications, and data (airflow, capacity, dimensions, or availability) are subject to change without notice, and may vary by region or country.

2 Product Description

The LP Baghouse is a continuous duty dust collector with bag-style filters designed to handle up to 141,000 cfm depending on the application and dust type. Continuous duty means the filters can be reverse air cleaned on-line without interrupting airflow through the collector. All bags are cleaned with every revolution of the cleaning arm.

The LP features a walk-in clean-air plenum, allowing filter bag service from inside the clean-air plenum.

Intended Use

The LP Baghouse is the recommended collector selection in the nut, woodworking and grain industries where it effectively handles high-volume, high dust-load applications.

Sizes are available for applications with any of the following conditions or requirements:

- Heavy dust load
- No compressed air available
- A requirement for a single discharge hopper

Standard Equipment

Filters

The LP collector ships with filter bags and cages. The standard bag media is Dura-Life™ which provides long life and energy savings due to lower pressure drop. Other filter bag media options are available.

Tangential Inlet

The inlet develops a cyclonic airflow causing heavier particulate to drop directly into the hopper. The air continues through an internal flow straightener, reduces turbulence and evenly distributes the dust-laden air within the collector cross-section and around the filter bags.

Tubesheet

The tubesheet separates the dirty-air plenum from the clean-air plenum while supporting the filter elements and cleaning system.

Clean-Air Access Plenum, Clean-Air Outlet, Roof

Clean, filtered air flows up through the tubesheet, through the clean-air access plenum and out the clean-air outlet.

Dirty-Air Plenum

Evenly distributed dust-laden air flows through the dirty-air plenum, around the filter bags, and clean-air exits through the tubesheet.

Hopper, Transition

Dust which drops out from the tangential inlet, along with dust being constantly cleaned from the filter elements exits the LP system through the hopper and transition. Access into the hopper and transition is also provided through the access panel located on the transition.

NOTICE

The hopper of the LP is not intended for dust storage.

Leg Pack/Support Structure

The entire LP collector is supported by the leg pack/support structure.

Collector Options and Accessories

Explosion Vent



Personal injury, death, and/or property damage can result from material discharge during venting.

The material discharged during the venting of an explosion must be safely directed outdoors away from areas occupied by personnel to reduce risk of personal injury and/or property damage.

The risk of personal injury and/or property damage can be minimized or avoided by locating vented equipment outside buildings and away from normally occupied areas.

Explosion vents should be inspected regularly to confirm physical and operational condition. Replace any damaged parts immediately.

Standard explosion vents are intended for outdoor installations only.

Unless otherwise noted, the explosion venting calculations are based on formulas from NFPA-68 for outdoor applications only, with no duct or obstructions on the explosion vent panel.

Contact Donaldson Torit for assistance in calculating specific venting requirements for equipment.

NFPA 68 can provide guidance on both the frequency of and appropriate details for inspections.

Platform/Ladder

Collector may be equipped with a platform/ladder system for gaining access to the clean-air plenum for filter bag changeout. For all ladders over 24-ft installed November 19, 2018 or later, OSHA requires a ladder safety system or personal fall arrest system. As a convenience, Donaldson offers ladder safety systems as an option.

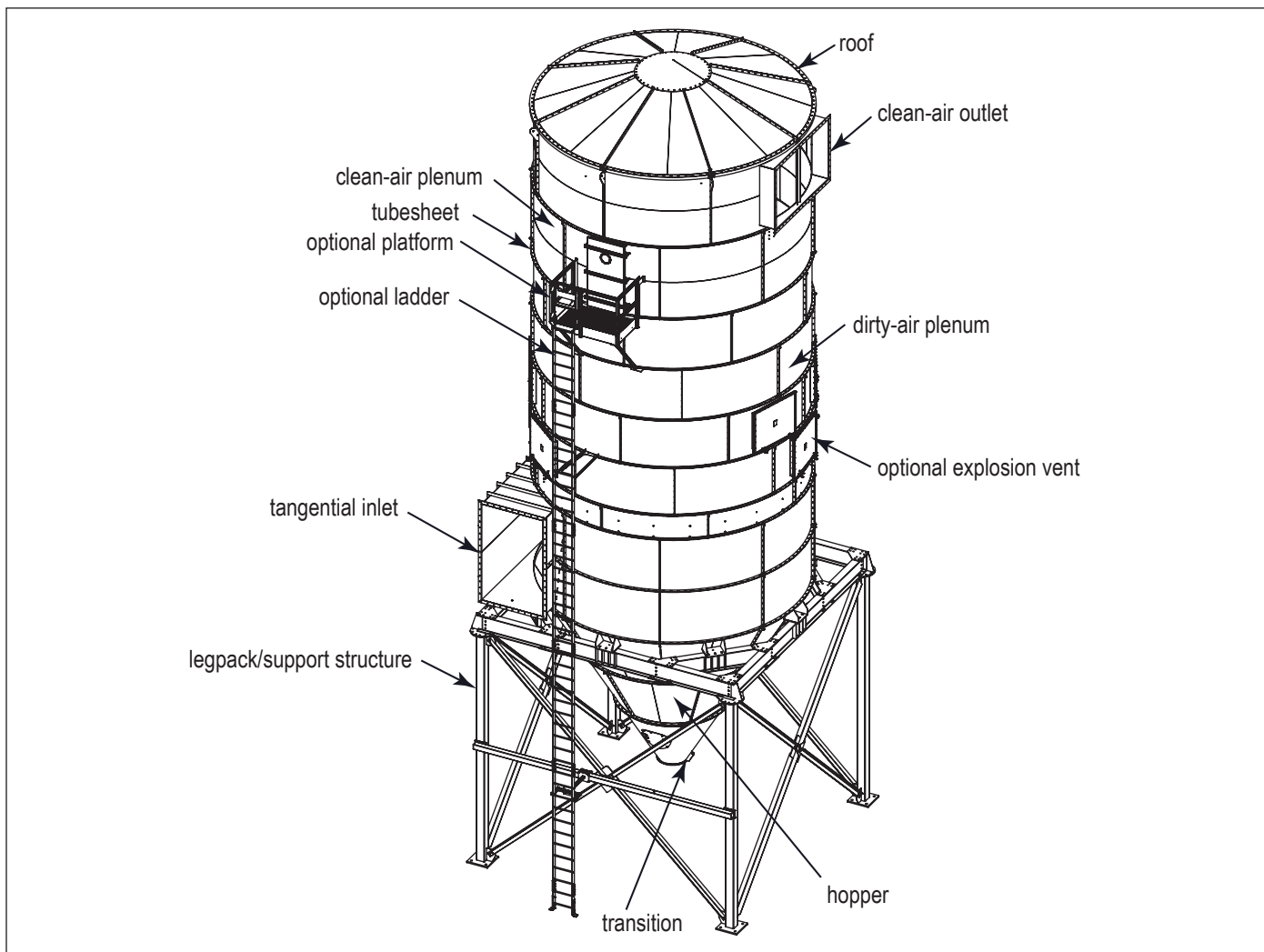

LP Typical Components

3**Operation**

Electrical work during installation, service or maintenance must be performed by a qualified electrician and comply with all applicable national and local codes.

Turn power off and lock out all power before performing service or maintenance work.

Turn compressed air supply off, bleed and lock out lines before performing service or maintenance work.

Check that the collector is clear and free of all debris before starting.

Do not install in classified hazardous atmospheres without an enclosure rated for the application.

During normal operation, dust-laden air enters the dirty-air inlet. The tangential inlet with helix develops a cyclonic airflow causing heavier particulate to drop directly into the hopper. The air continues through an internal flow straightener that evenly distributes the dust-laden air within the collector cross-section and around the filter bags. After entering the collector the light dust collects on the outside surface of each filter bag forming a dust cake. Clean, filtered air passes through the filter bags to the clean-air plenum and discharges through the clean-air outlet.

Reverse Air Internal Cleaning System

The cleaning system contains an internal fan with reverse air flow design. The sweep arms have a flow-stop plate which keeps air from flowing through the bag filters before and after cleaning. This feature reduces the chances of dust from cleaned bags being re-entrained onto recently cleaned bags, resulting in lower pressure drop and reduced energy costs due to bags staying cleaner longer. The system does not require any compressed air supply.

Typical Collector Start-Up/Shut-Down Sequence**Start-Up**

1. Start material discharge mechanism such as a rotary airlock (if applicable).
2. Start gear box motor for cleaning arm rotation.
3. Start reverse-air cleaning assembly fan.
4. Start main system fan.
5. Start process equipment.

Shut-Down

1. Stop process equipment. Allow main system fan and LP to continue operating for 10-15 minutes to clear dust from conveying ducts.
2. Stop main system fan. Allow LP reverse-air fan and gear box motor to continue running for 5-10 minutes for a brief period of enhanced filter bag cleaning.
3. Stop LP reverse-air fan and gear box motor. Allow material discharge mechanisms to run for 10-15 minutes after reverse-air fan and gear box motor shut off to ensure dust is fully evacuated from the hopper of the LP.
4. Stop material discharge mechanism.

Note: Some filters and the cleaning system components (fan, rotating arm and arm drive assembly) are not shown for clarity.

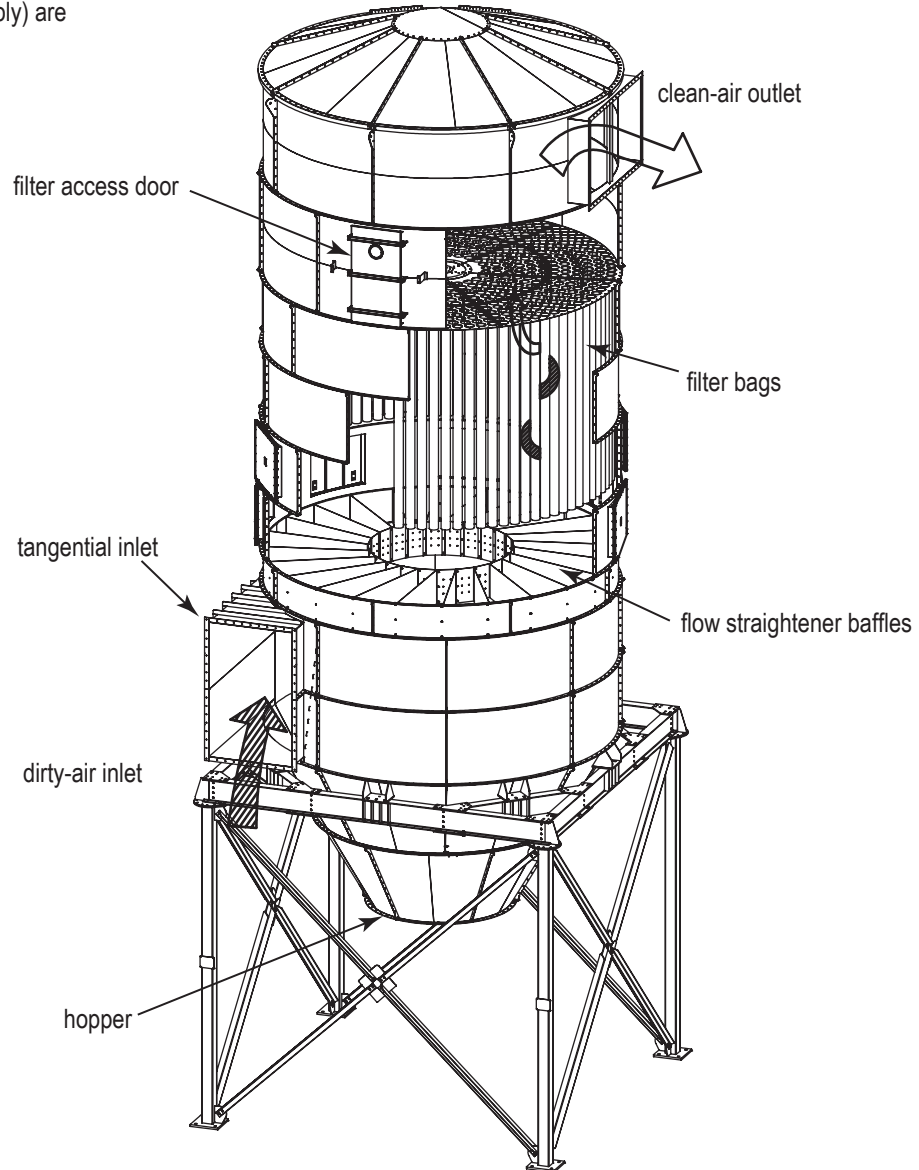

Collector Operation

4 Product Service



During any service activities there is some potential for exposure to the dust in the collector. Most dusts present safety and health hazards that require precautions. Wear eye, respiratory, head, and other protection equipment suitable for the type of dust when performing any service activities.

Use appropriate access equipment and procedures. Note the standard collector is not equipped with access platforms unless noted on the specification drawing.

LOCK-OUT all energy sources prior to performing any service or maintenance on the equipment.

Electrical service or maintenance work must be performed by a qualified electrician and comply with all applicable national and local codes.

Donaldson Torit filters require little maintenance in most applications. Bags require replacement on a periodic basis. The severity of the application will dictate the time interval for bag replacement.

1. Monitor the physical condition of the collector and repair or replace any damaged components.

Routine inspections will minimize downtime and maintain optimum system performance. This is particularly important on continuous-duty applications.

2. Monitor pressure drop across filters.

Abnormal changes in pressure drop may indicate a change in operating conditions and possibly a fault to be corrected.

3. Monitor exhaust for any signs of material emissions/bypass.
4. Monitor dust disposal out of the hopper discharge opening.

Check the following items at the recommended intervals shown below.

Weekly

1. Check that pressure drop is within normal operational range.

Quarterly

1. Check/monitor drive chain tension and lubrication of upper and lower bearing.
2. Check reverse air cleaning fan wheel set screw and tighten if necessary.
3. Check reverse air cleaning fan wheel for excessive noise and/or vibration.
4. Check condition of the clean-air plenum. If dust accumulation is present, check filter bags for damage or wear and replace as necessary.
5. Check the rotating arm drive gear reducer oil level. The gear reducer is filled with AGMA 8c or equivalent oil. See reducer manual for more information.

Annual

1. Verify smooth operation of cleaning arm/skid.
2. Monitor thickness of wear material on the cleaning skid, look for filter cages not fully inserted into tubesheet.
3. Check structural support for any signs of damage or wear and take appropriate steps to correct any problems.
4. Inspect explosion vents, if applicable, for signs of damage or wear and replace as necessary.
5. Check door seals for signs of damage or wear and replace as necessary.

Filter Replacement



Most dusts present safety and health hazards that require precautions. Wear eye, respiratory, head and other protection equipment suitable for the type of dust.

Use proper safety and protective equipment when removing contaminants and filters.

Dirty filters may be heavier than they appear. Use appropriate lifting methods to avoid personal injury and/ or property damage.

Turn power OFF and lock out all power before performing service or maintenance work.

Do not operate with missing or damaged filters.

1. Follow shut-down sequence for the collector.
2. Turn power OFF and lock out all power.
3. Access clean-air plenum through access door.
4. Remove cages leaving the bags hanging in dirty-air plenum.
5. Push one side of snap band to deform and release from the tubesheet. See Filter Replacement illustration.
6. Push the bag down into the bottom of the dirty-air plenum.

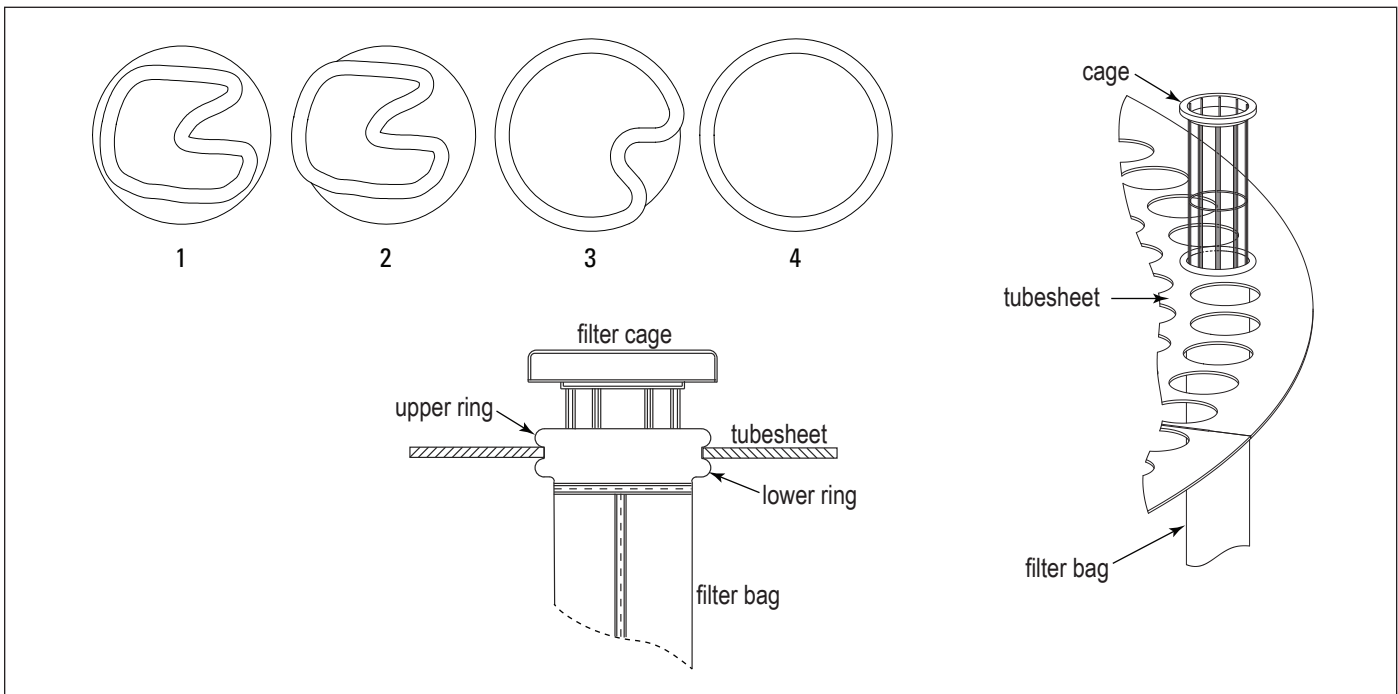

Filter Replacement

7. Repeat steps 3-4 for each bag.

Note: The cleaning arm will need to be manually rotated to access some bags.

8. Remove all dirty bags through hopper access door.
9. From the clean-air plenum, carefully insert the snap band filter bag through the tubesheet with the closed end oriented downward.
10. Snap the bag in place with the tubesheet between the upper and lower rings on the filter bag collar. See Filter Installation illustration.
11. Slide the filter cage into the filter bag and seat firmly.
12. Repeat steps 7-9 for all bags.

Note: The cleaning arm will need to be manually rotated to access some bags.

13. Once all bags are installed, ensure the cleaning arms rotate smoothly.
14. Close and tighten clean-air plenum access door.
15. Follow start-up sequence to return collector to service.

Troubleshooting

Problem	Probable Cause	Remedy
Fan blower and motor do not start	Improper motor wire size	Rewire using the correct wire gauge as specified by national and local codes.
	Not wired correctly	Check and correct motor wiring for supply voltage. See motor manufacturer's wiring diagram. Follow wiring diagram and the National Electric Code.
	Collector not wired for available voltage	Correct wiring for proper supply voltage.
	Input circuit down	Check power supply to motor circuit on all leads.
	Electrical supply circuit down	Check power supply circuit for proper voltage. Check for fuse or circuit breaker fault. Replace as necessary.
	Damaged motor	Replace damaged motor.
Fan blower and motor start, but do not stay running	Incorrect motor starter installed	Check for proper motor starter and replace if necessary.
	Access doors are open or not closed tight	Close and tighten access doors. See Filter Installation.
	Hopper discharge open	Check that main system fan is installed and properly sealed.
	Damper control not adjusted properly	Check airflow in duct. Adjust main system fan damper control until proper airflow is achieved and the blower motor's amp draw is within the manufacturer's rated amps.
	Electrical circuit overload	Check that the power supply circuit has sufficient power to run all equipment.
Clean-air outlet discharging dust	Filters not installed correctly	See Filter Replacement.
	Filter damaged or worn	Replace filters as necessary. Use only genuine Donaldson replacement parts. See Filter Replacement.
Insufficient airflow	Fan rotation backwards	Proper fan rotation is clockwise when viewed from the motor side or counterclockwise when viewed through the inlet cone. See Start-Up/Commissioning .
	Access doors open or not closed tight	Check that all access doors are in place and secured. Check that the hopper discharge opening is sealed and that dust container is installed correctly.
	Fan exhaust area restricted	Check fan exhaust area for obstructions. Remove material or debris. Adjust damper flow control.
	Filters need replacement	Remove and replace using genuine Donaldson replacement filters. See Filter Replacement.

Problem	Probable Cause	Remedy
Pressure drop not in normal operational range	Collector overloaded at dust source	Check for excessive or unusual dust loading at the dust source.
	Hopper bridging	Check for proper flow at product discharge flange on filter hopper.
	Cleaning system	Verify no debris or condensation in tube length running to gauge Check operation of LP reverse air cleaning fan. Check operation of LP gear box and drive.
Power circuit for sweep arm motor trips	Interference between sweep arms and cages	Ensure all filter cages are fully seated. Ensure skid material is in good condition and arms rotate freely. Replace if necessary.

Appendix A - Installation

Installation



Electrical installation (including bonding and grounding of the collector) must be performed by a qualified electrician.

This equipment is not designed to support site ducts, piping, or electrical services. All ducts, piping, or electrical services must be adequately supported to prevent injury and/or property damage.

Do not install in classified hazardous atmospheres without an enclosure rated for the application.

Service must be performed by trained and qualified maintenance personnel.

Equipment may reach peak sound pressure levels above 80 dB (A). Noise levels should be considered when selecting collector location.

Location and Site Selection

Equipment location must conform to all codes and standards, should be suitable for the type of dust being handled and should ensure easy access for service and utility connections. Site selection must account for wind, seismic zone, and other load conditions.

The equipment must be adequately anchored once in final position. Foundation or support framing must be capable of supporting dead, live, wind, seismic and other applicable loads. Consult a qualified engineer for final selection of foundation or support framing.

Provisional Anchor Bolt Recommendations

The quantity of anchor bolts should match the number of holes provided in the base plates of the collector. Anchor diameter is typically 1/8-inch less than the baseplate hole diameter. Anchors should project a minimum of 1 3/4 -inch and account for nut, washer, baseplate, and shims/grout.

Consider Hilti HIT-HY 200 Anchor Systems or equivalent.

Delivery and Inspection

Upon arrival inspect collector and report any damage to delivery carrier. File any damage claims with the delivery carrier. Request a written inspection report from the Claims Inspector to substantiate all damage claims.

Compare the collector received with the description of product ordered. Report any inconsistencies or incomplete shipments to the delivery carrier and your Donaldson Torit representative.

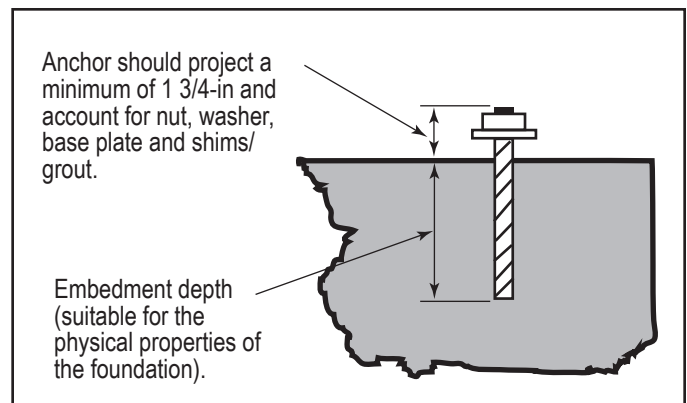

Typical Foundation Anchor

Unloading and Positioning



Collector and components should be lifted only by qualified crane or fork truck operators.

Failure to lift the collector or components correctly can result in severe personal injury and/or property damage.

Label on pack slip and bill of lading will state weight as delivered.

1. Remove any crates or shipping straps.
2. Lift the packaged collector or components from transport container.
3. Use all lifting points provided.
4. Use clevis connectors, not hooks, on lifting slings.
5. Use spreader bars to prevent damage to collector's casing.
6. Check the Specification Control drawing for weight and dimensions of the collector and components to ensure adequate crane capacity.
7. Inspect for any damage and/or missing parts and report to freight carrier.
8. Check for any hardware which may have become loose during shipment and tighten as necessary.

Lift collector and accessories separately and assemble after collector is in place.

Use drift pins to align holes in section flanges during assembly.

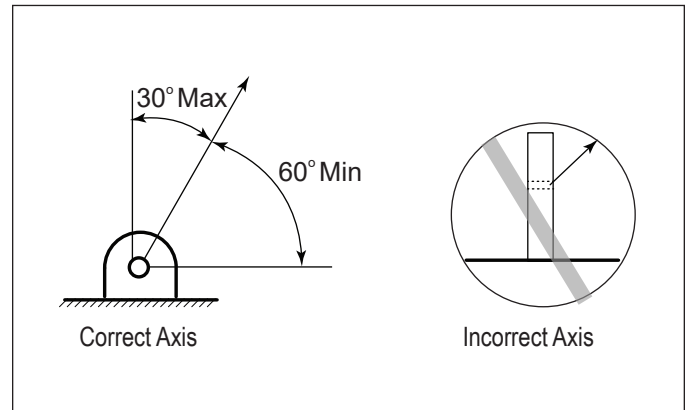

Lifting

LP General Assembly Sequence Overview



Electrical installation must be performed by a qualified electrician.

Duct fabrication and installation must be performed by a qualified tinsmith or contractor.

This equipment is not designed to support site ducts, piping, or electrical services. All ducts, piping, or electrical services must be adequately supported to prevent injury and/or property damage.

The following steps summarize the order in which to assemble the collector. Depending on the process owner's situation a different sequence may be more appropriate. Each of the following steps is explained in detail on the following pages. Read the full installation instructions for clarification and important details before beginning assembly.

1. Leg Assembly - assemble legs, cross bracing and I-Beam frame
2. Tubesheet Assembly - this step is critical because all other sections will be aligned and assembled on the tubesheet, using the tubesheet as a template.
3. Hopper Assembly - assemble, then invert and lift into place.
4. Tangential Inlet Assembly - assemble the inlet which makes up the outside ring wall of the inlet deflector section and lift into place.
5. Bag Section Assembly - assemble dirty-air plenum Bag Section panels to create each ring assembly and lift into place.
6. Clean-Air Access Plenum Assembly - assemble clean-air exhaust plenum and roof section and set aside on a level surface.
7. Clean-Air Outlet Plenum and Roof Installation - assemble roof together and onto clean-air outlet plenum.
8. Tubesheet Installation and Support Column - lift tubesheet and attaching upper support column.
9. Lower Plenum Access Section Attachment and Internal Cleaning Assembly - attach the first ring assembly to tubesheet and installing filter cleaning assembly.
10. Filter Bag and Cage Installation - installation of filter bags and cages from the clean-air plenum.
11. Clean-Air Outlet Plenum and Roof Section Attachment - attach the exhaust plenum access and roof section to the Lower Plenum Access section.
12. Exhaust Ducting - attach exhaust ducting to clean-air outlet plenum
13. Ladder/Platform Installation - mount the platform to the plenum access section and installing ladders.
14. Additional Ducting - connect of any remaining ducting to collector.
15. Material Discharge Mechanism - install onto collector hopper.
16. Electrical Connections - Process Owners are responsible for installation of electrical connections.
17. Fire Mitigation Systems - Consult with local authorities when installing fire control systems on dust collection equipment.
18. Structural Connections - structural connections must be inspected for proper torque prior to commissioning the collector.
19. Electrical and Mechanical Connections - before commissioning collector, all electrical and mechanical connections must be inspected and approved.

R= Roof Section

E = Exhaust Plenum (Clean-Air Outlet Plenum)

LP = Lower Plenum Access (Clean-Air Access Plenum)

BS1 = Bag Section 1

BS2 = Bag Section 2

BS3 = Bag Section 3

BS4 = Bag Section 4

D = Deflector Section

UI = Upper Inlet

LI = Lower Inlet

UH = Upper Hopper

LH = Lower Hopper

T = Transition

A = Material Discharge Mechanism

Parts labeled in this illustration are for each ring of the collector and packaged in racks with a stamped metal tag denoting which ring it belongs with.

For example, all the panels needed to create the BS1 ring are included in a pack labeled BS1.

For shipments with multiple collectors, the "-1" will denote which collector that rack of parts belongs to.

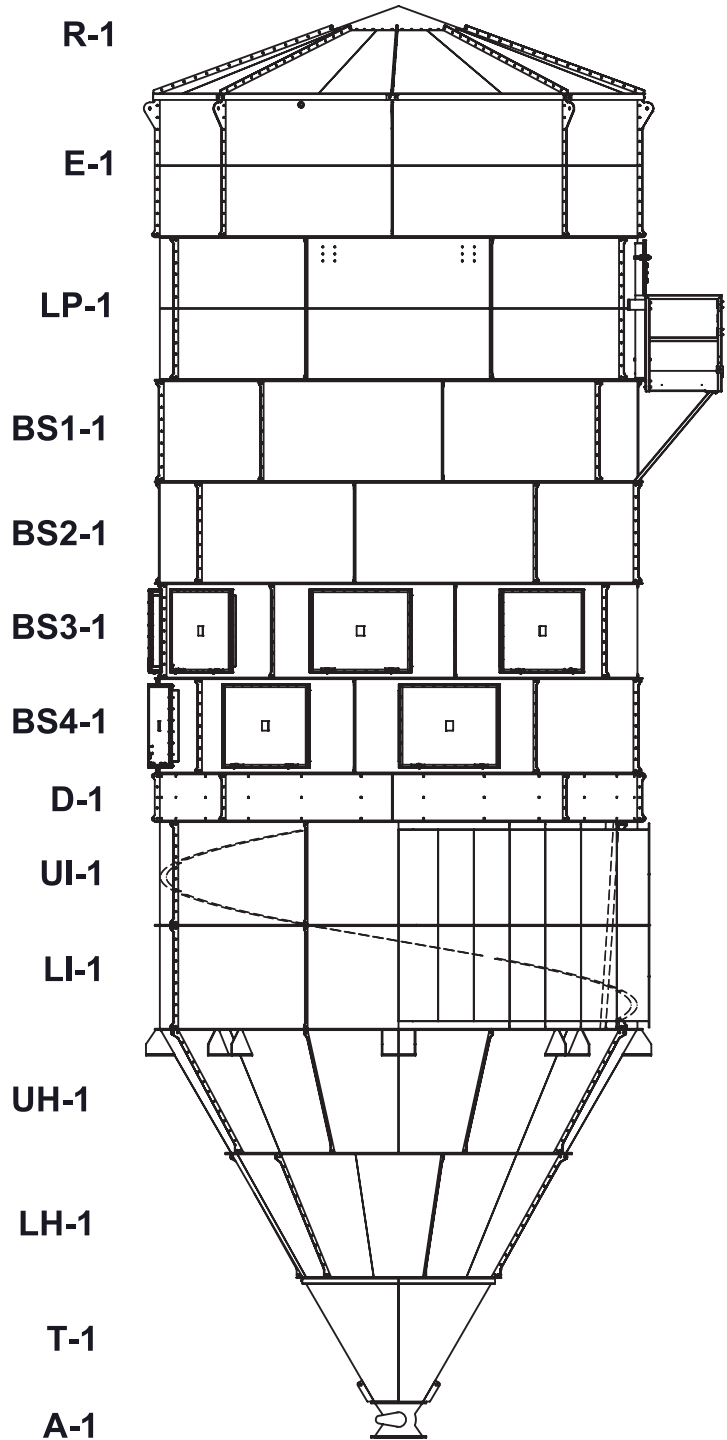

1. Leg Assembly

Reference Typical Foundation Anchor and leg assembly drawing shipped with the collector prior to starting assembly.

2. Prepare the foundation or support framing in the selected location. Locate and install anchors.
3. Set the legs onto the pre-poured foundation and bolt tight.
4. Install all cross-braces spanning the legs using the 3/4-in supplied hardware.
5. Keep bolts partially tightened until the I-beam perimeter frame can be set into place.
6. Lay out the I-beam frame at grade level and install hardware hand tight.
7. Lift the I-beam frame onto the leg structure, ensuring frame is level and plumb.
8. Tighten all hardware.



Tighten all hardware before removing crane to prevent personal injury and/or property damage.

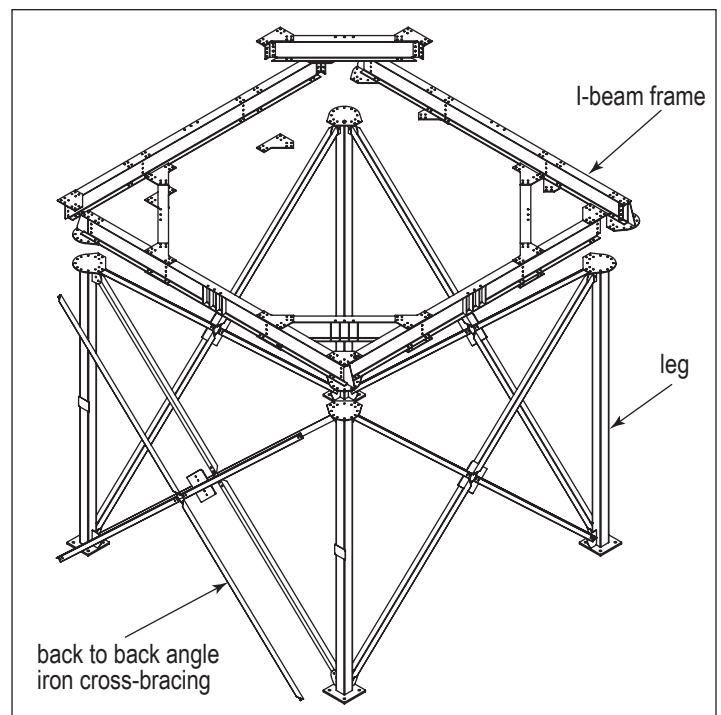

Leg Assembly

2. Tubesheet Assembly

1. Lay out the radial stiffeners of the tubesheet on a level area using stand-offs to avoid ground contact and to keep the surfaces free from blemishes.
2. Connect the radial stiffeners together forming a central hexagonal tube (see Tubesheet Stiffener Connection and Sealant).
Note: bolts should be hand tight at first so that all pieces can be aligned properly before fully tightening.
3. Connect curved stiffeners to radial stiffeners. Hand tighten bolts until stiffeners are aligned.
4. Apply 1/4-in bead of sealant on each flange and around perimeter of bolt holes, of all radial and curved stiffeners shown on Tubesheet Stiffener Connection and Sealant illustration. This provides an airtight seal to develop when the tubesheet pie sections are installed and bolted in place.
5. Install all tubesheet pie sections using flanged hardware in all square holes and using bolt/nut hardware in all circular holes. Reference Hardware Table and Tubesheet Connection Layout illustration.
6. After all pie sections are in place, bolt the center plate in place.
7. Install the center cap weldment with the center pipe inserted down through the cap plate center hole.
8. Align and tighten all bolts.

Bolted connections have been designed as “non-pretensioned bolted joints” or “bearing type” connections, per AISC. Bearing type connections require all plies of the connected elements be brought into snug tight condition. Snug tight condition is defined as the tightness that exists when all plies in a joint are in firm contact. This may be attained by a few impacts of an impact wrench or the full effort of an ironworker using an ordinary spud wrench to bring the plies into firm contact.

If preferred, a reference guide indicating torque values is located in the Hardware Table. Note this is a reference guide only relaying guidance taken from hardware supplier torque-tension reference guide.

Hardware Table			
Size	Assembly	Type	Recommended Bolt Torque (ft/lbs)
3/8-in	Ladder Platform	Bolt/Nut Bolt/Nut	25-30
1/2-in	Hopper Body(ies) Tangential Inlet Roof	Flanged Flanged Flanged Flanged	55-75
5/8-in	Tubesheet	Bolt/Nut	110-150
3/4-in	Leg Structure	Bolt/Nut	200-260

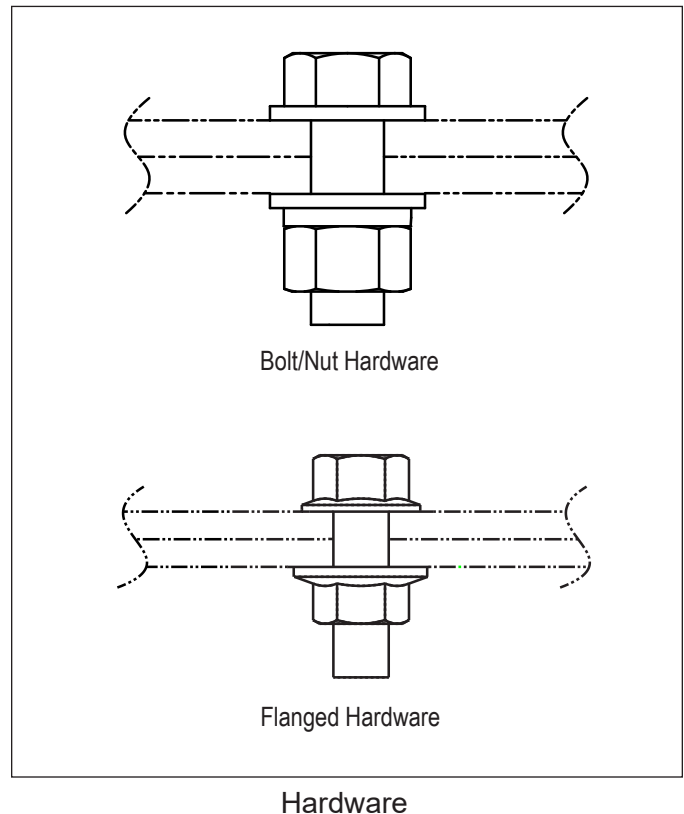

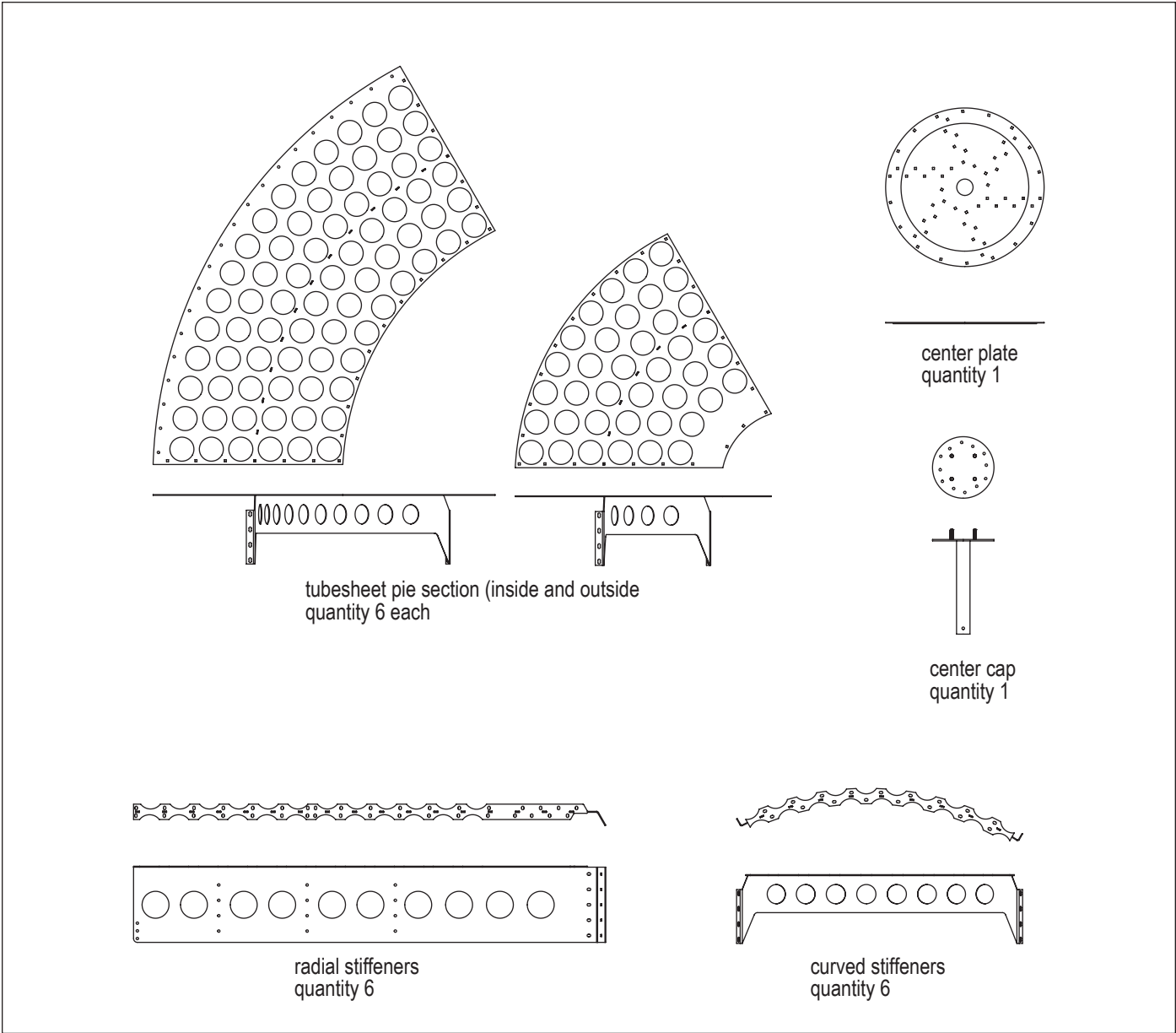

Tubesheet Assembly Items

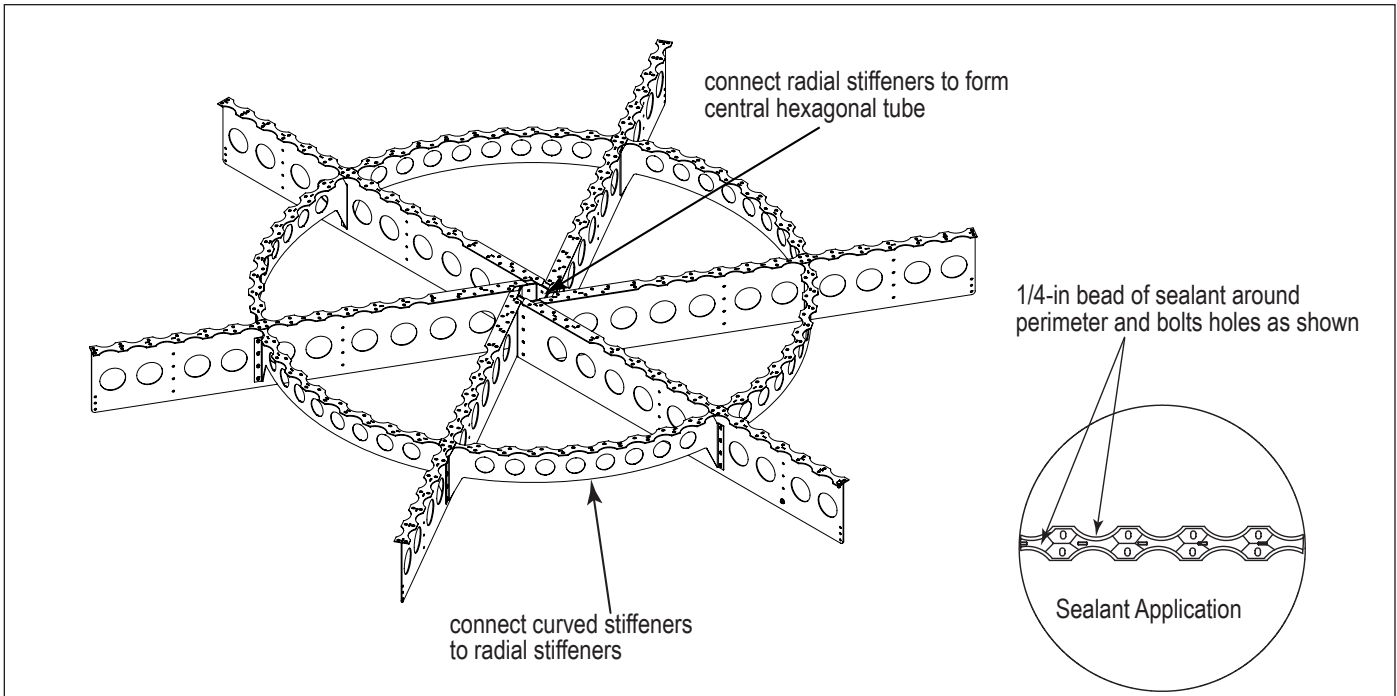

Tubesheet Stiffener Connection and Sealant

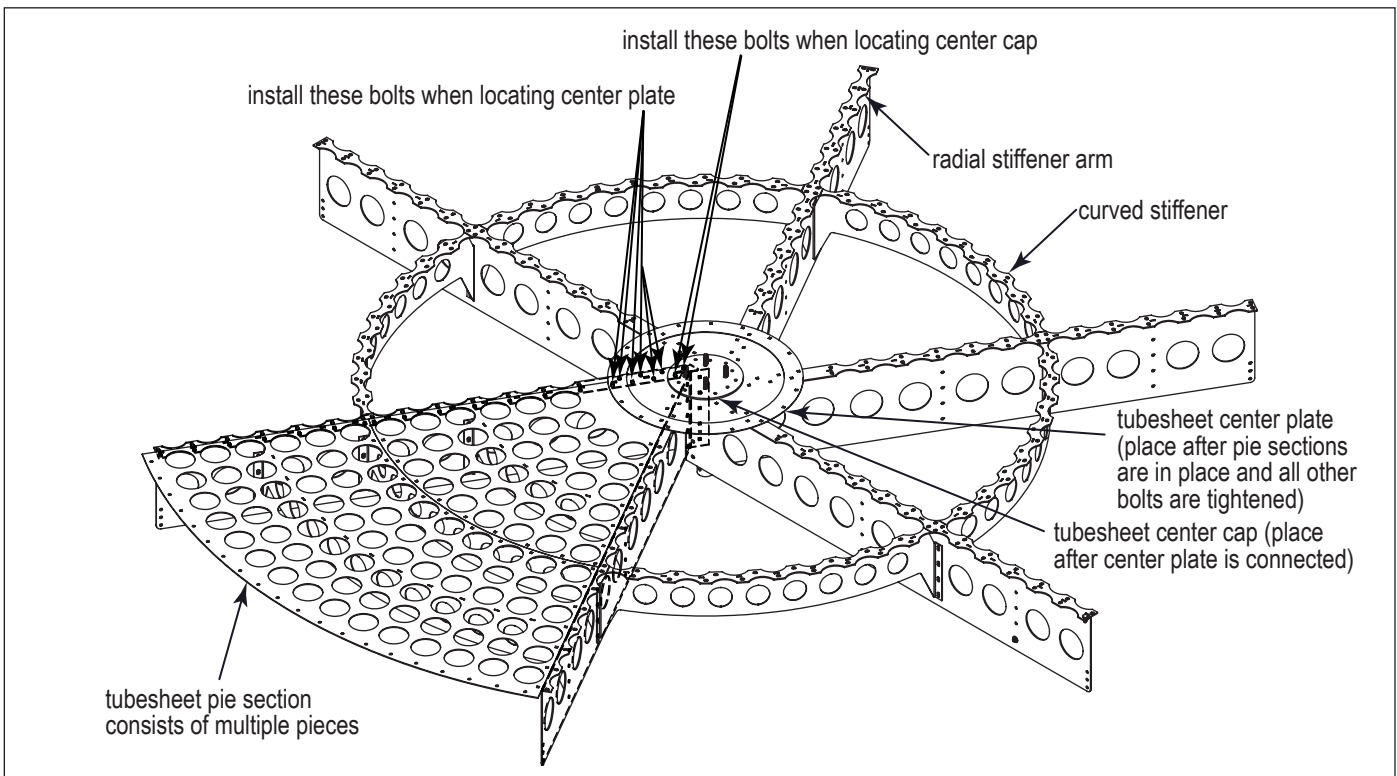

Tubesheet Connection Layout

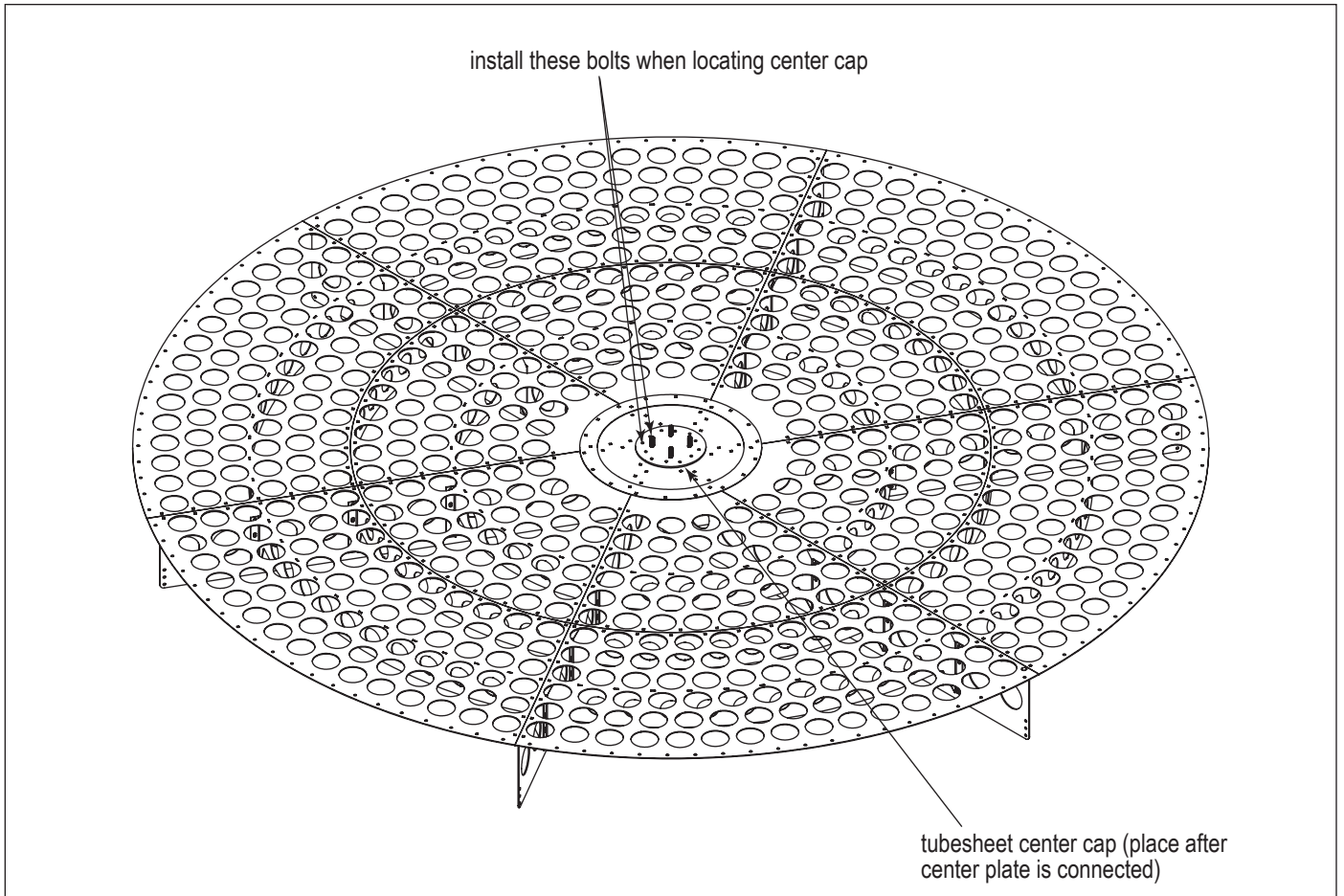

Tubesheet (Upright) Top Connecting Plate

3. Hopper Assembly

1. Mount the first hopper panel upside down on the tubesheet. In this step and subsequent steps, the tubesheet will be used as a template to ensure correct alignment when joining subassemblies together. Align the outer bolt pattern of the hopper panel with the corresponding pattern on the tubesheet. Do not apply sealant between the hopper panel and the tubesheet.
2. Temporary supports at the ends of each hopper panel may be required until the hopper ring is complete.
3. Before connecting the adjacent hopper panel, apply sealant to the mating flange within 1/8-in of both flange edges as shown.
4. Set the next panel and hand-tighten the hardware (connecting bolts should draw the adjoining flanges together but still allow for some slippage). Repeat steps until upper hopper assembly is complete.
5. If there is a middle hopper assembly, assemble it in the same way as the upper hopper assembly.
6. After the hopper sections are assembled, apply sealant to the top of the upper flange as shown to prepare for the middle hopper level assembly to be set.
7. Lower the middle hopper assembly onto the upper hopper assembly and hand tighten the hardware.
8. Once the middle hopper is attached to the upper hopper, apply sealant and attach the lower hopper assembly and hand tighten the hardware.
9. Apply sealant, attach the hopper transition and hand tighten the hardware.

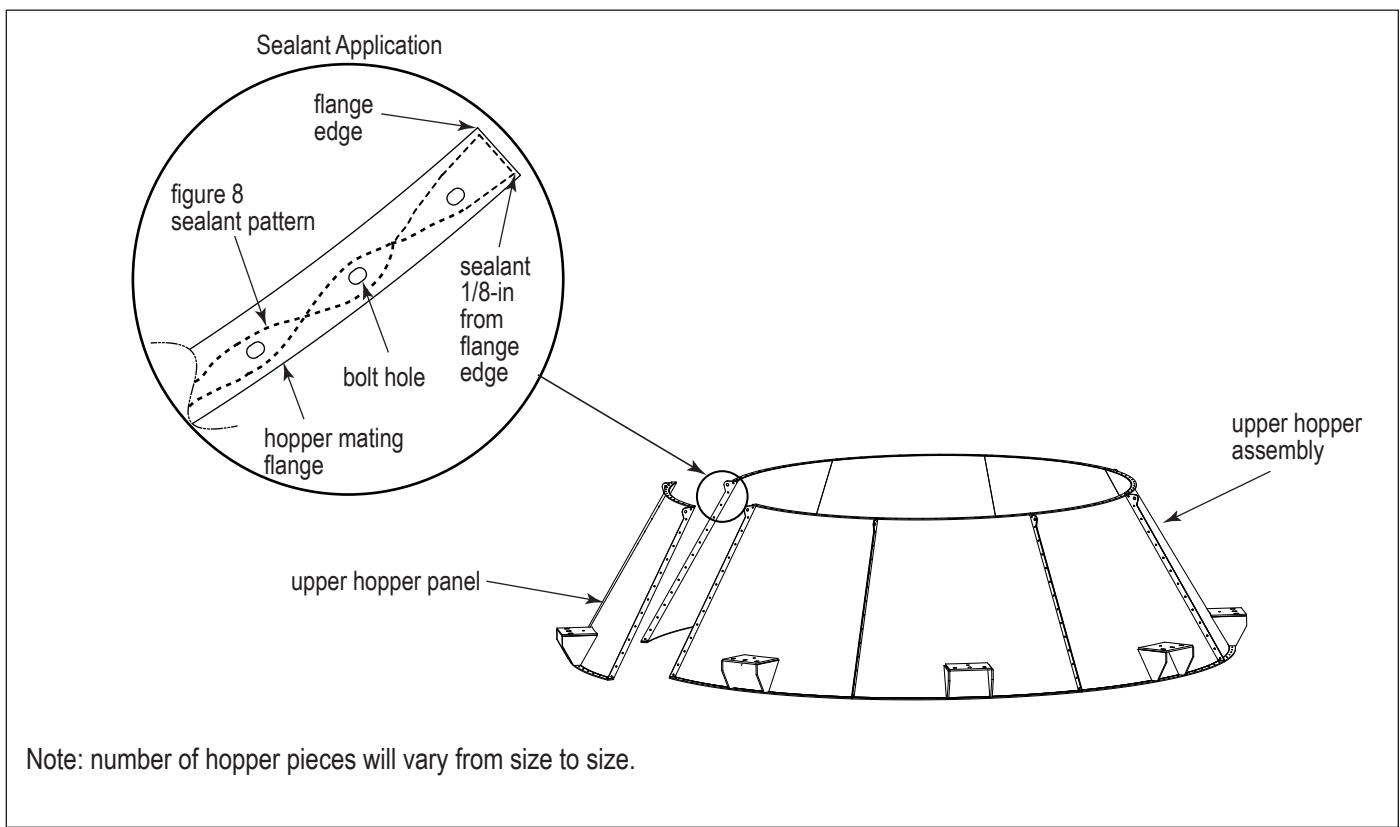

Upper Hopper Assembly (Upside Down)

10. Align the hopper access door with a mating seam of the hopper assembly. This will force the transition flange's bolt pattern to straddle the centerline of the collector.
11. Insert all bolts connecting the transition assembly to the hopper assembly and tighten. Proceed by tightening all bolts of the hopper assembly.
12. After hopper assembly is completely bolted and tightened, undo any bolts connecting it to the tubesheet (if used).
13. Lift the hopper and rotate it to the upright position.
14. Utilize straps/cables attached to hopper support feet for main vertical support of weight during lifting. Utilize lifting lugs on hopper panels along with hopper transition to attach and guide during rotation.



Use caution when lifting/rotating hopper. Keep tension on all straps/cables when lifting. Failure to comply may result in personal injury and/or property damage.

Temporary lifting points require Grade 5 hardware (supplied with collector). Using any other grade may result in lifting lug failure and personal injury and/o property damage.

Water overflow drains are required if fire mitigation system is installed.

15. Attach the four temporary lifting points at the marked locations (0°, 90°, 180° and 270°) to the top of the hopper.

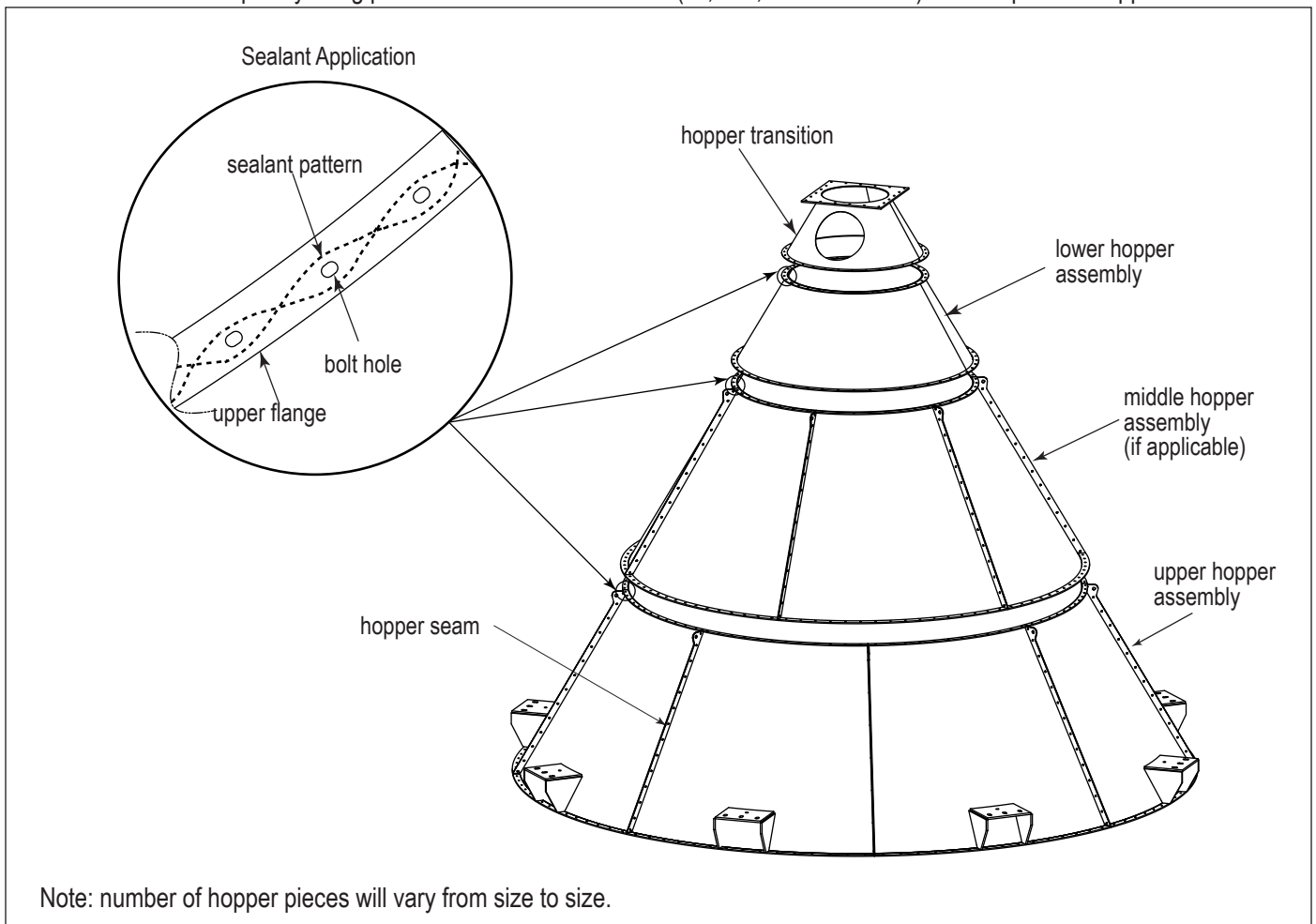

Hopper Assembly (Upside Down)

16. Align the arrow indicators inside the hopper feet (in the 0°, 90°, 180°, and 270° positions) per the configuration drawing. See illustration below.
17. In this orientation, lower the hopper assembly into the leg frame. Fasten the hopper assembly securely to the I-beam frame with the provided 3/4-in hardware.
18. Remove and retain the four temporary lifting points and mounting hardware for use on other sub-assemblies.

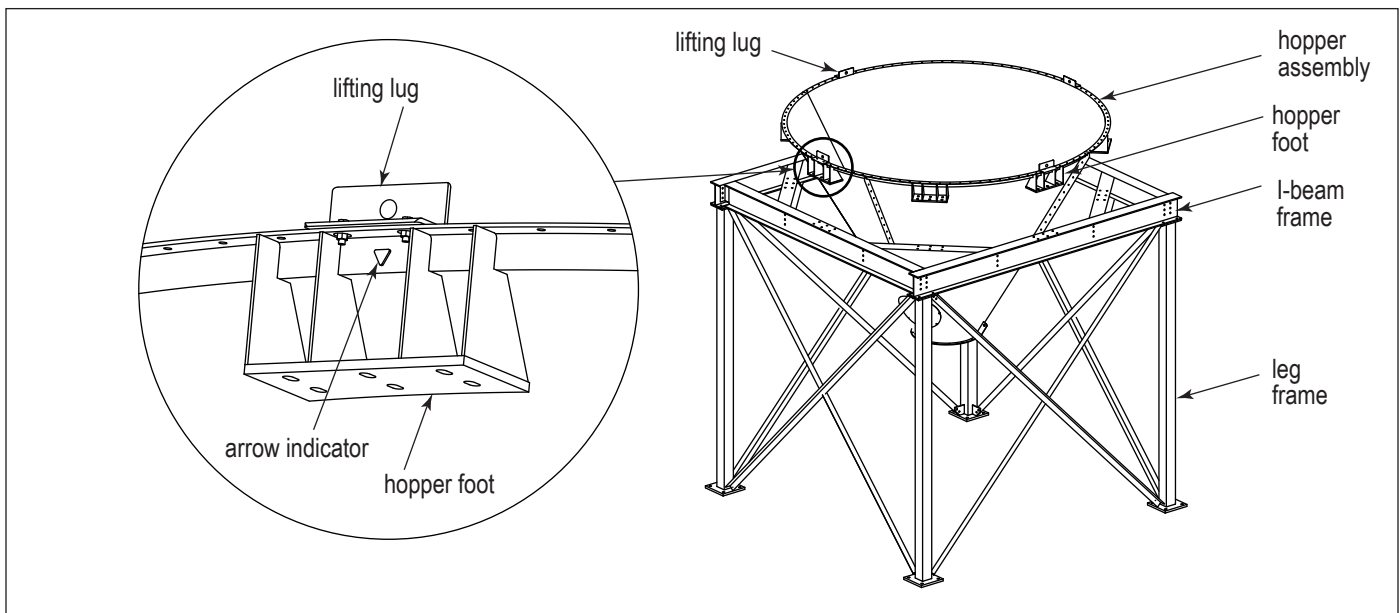

Hopper to Leg Frame Installation

Note: Lifting points Bolt-On Usage - use the provided bolt-on lifting points and grade 5 hardware when moving panels into position. Position the lugs such that excess swaying will be minimized. When lifting an assembly, use all four lugs with the backer plates attached.

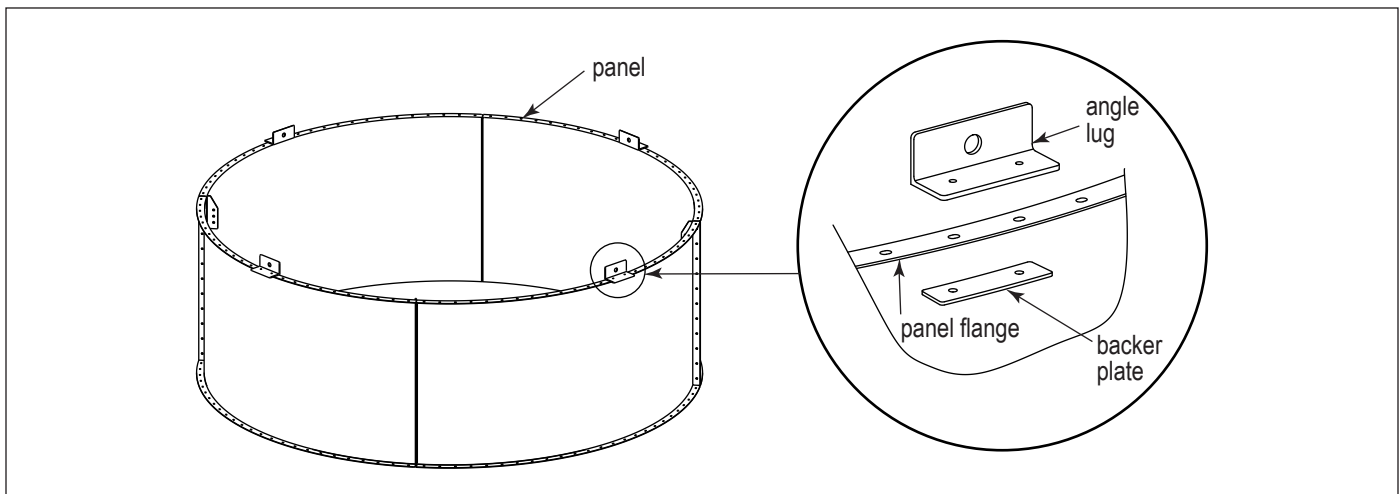

Bolt-On Lifting points

4. Tangential Inlet Assembly

1. Place the short panels, which make up the outside ring wall of the inlet deflector section, onto the tubesheet. The tubesheet is used to align the panels as in previous sections. Do NOT apply sealant between the tubesheet and the short panels.
2. Prior to setting an adjacent panel, apply sealant to all external vertical flanges within 1/8-in from flange edge as shown. Repeat for each short panel.
3. Once the short panels are joined and bolted, bolt the deflector plates to the ring wall and to each other.
Note: Deflector plates can be installed for clockwise rotation (shown) or counter clockwise (opposite of shown).
4. Tighten deflector plate bolts.
5. Lift the deflector section assembly from the tubesheet and set aside.
6. Place the tangential inlet body panels which form the bottom ring of the inlet onto the tubesheet one panel at a time, using the tubesheet as a template. Do NOT apply sealant to the tubesheet.

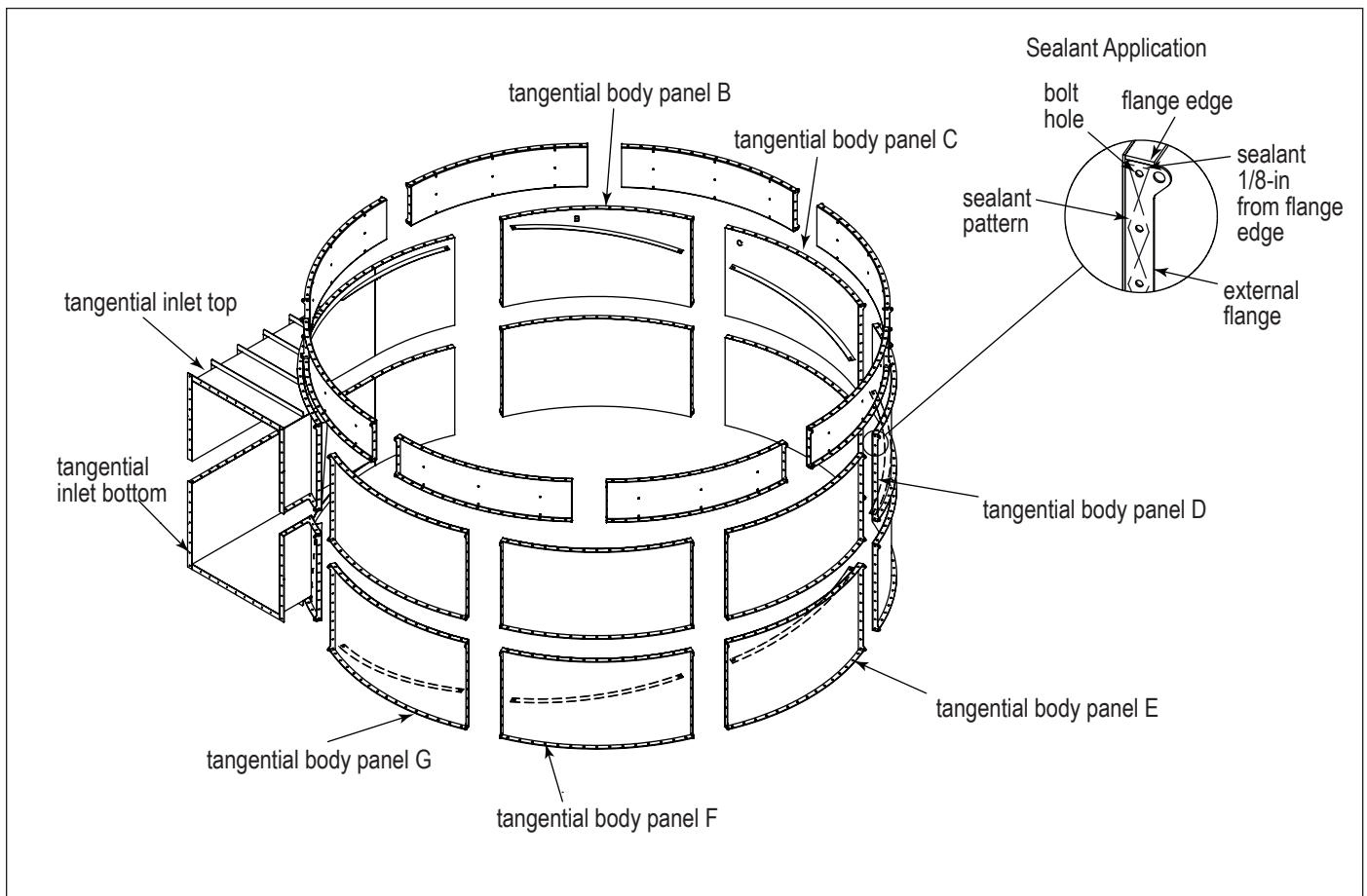

Tangential Panel Assembly

7. Prior to setting an adjacent panel, apply sealant as explained in Step 2. Repeat for each tangential inlet body panel for the bottom ring.

Note: When placing inlet sections next to each other, make sure the spiral deflector inside of the inlet section is continuous. Refer to tangential body panels marked E, F, and G in Tangential Panel Assembly illustration.

8. Once the panels for the bottom ring of the tangential inlet are joined and bolted, lift the assembly from the tubesheet and set aside.
9. Place the tangential inlet body panels which form the middle ring of the inlet onto the tubesheet, using the tubesheet as a template. Do NOT apply sealant to the tubesheet.
10. Prior to setting an adjacent panel, apply sealant as explained in Step 2. Repeat for each tangential inlet body panel for the middle ring.

Note: When placing these inlet sections next to each other, make sure the spiral deflector inside of the inlet section is continuous. Refer to tangential body panels marked B, C and D shown in Tangential Panel Assembly illustration.

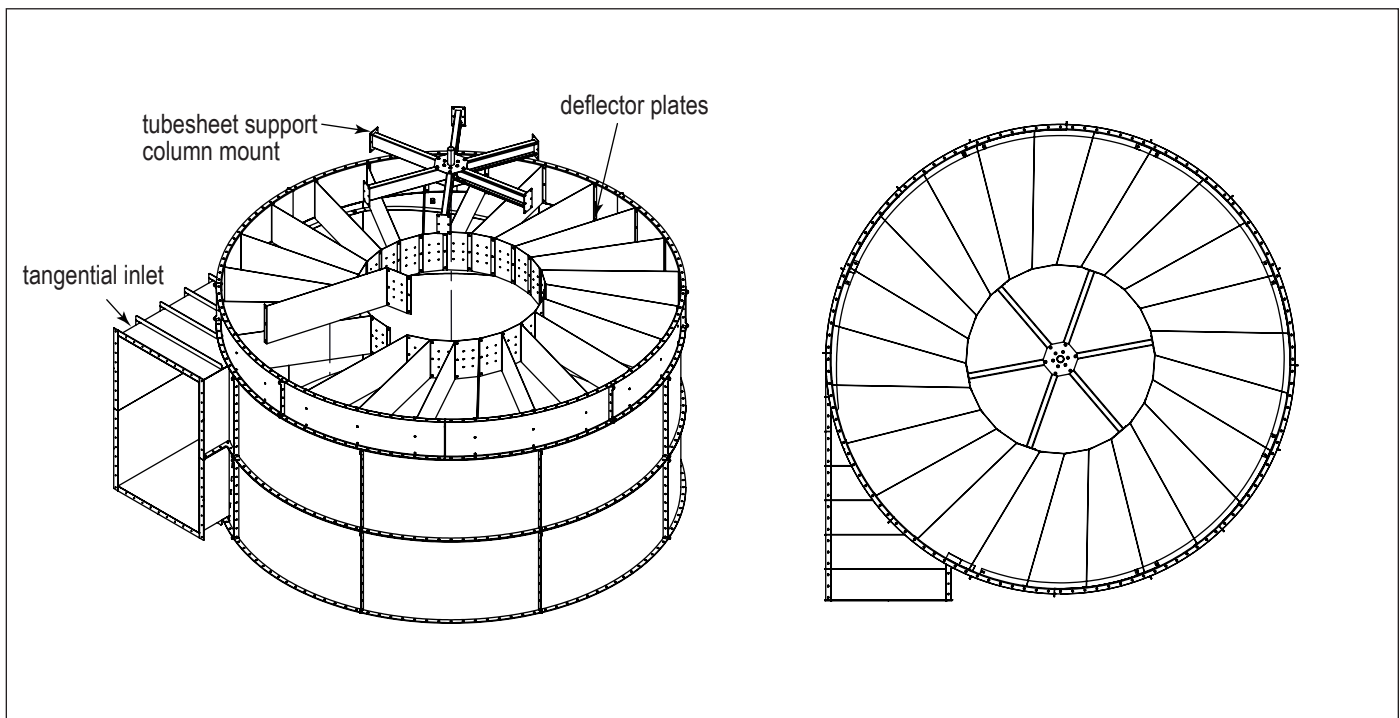

Tangential Inlet

11. Prepare the top flange of the bottom ring of the inlet section with a bead of sealant following the sealant pattern shown.
12. Lift the middle tangential inlet ring off the tubesheet and install onto the prepared top flange of the bottom ring of the inlet. Align and bolt together.
13. Prepare the top flange of the middle ring of the inlet section with a bead of sealant following the pattern shown.
14. Lift the deflector section assembly onto the prepared top flange of the inlet section. Align and bolt together.
15. Install the Tubesheet Support Column Mount into the deflector section.
16. Prepare the top flange of the hopper with sealant as shown.
17. Use the provided lifting points on the deflector section and grade 5 hardware to lift the entire tangential inlet assembly and install onto the hopper.
18. Inspect the orientation of the inlet ensuring the inlet flange is parallel with the support beam frame as shown on the drawing shipped with collector. As the inlet is lowered onto the hopper, align all holes and bolt tightly with 1/2-in hardware.

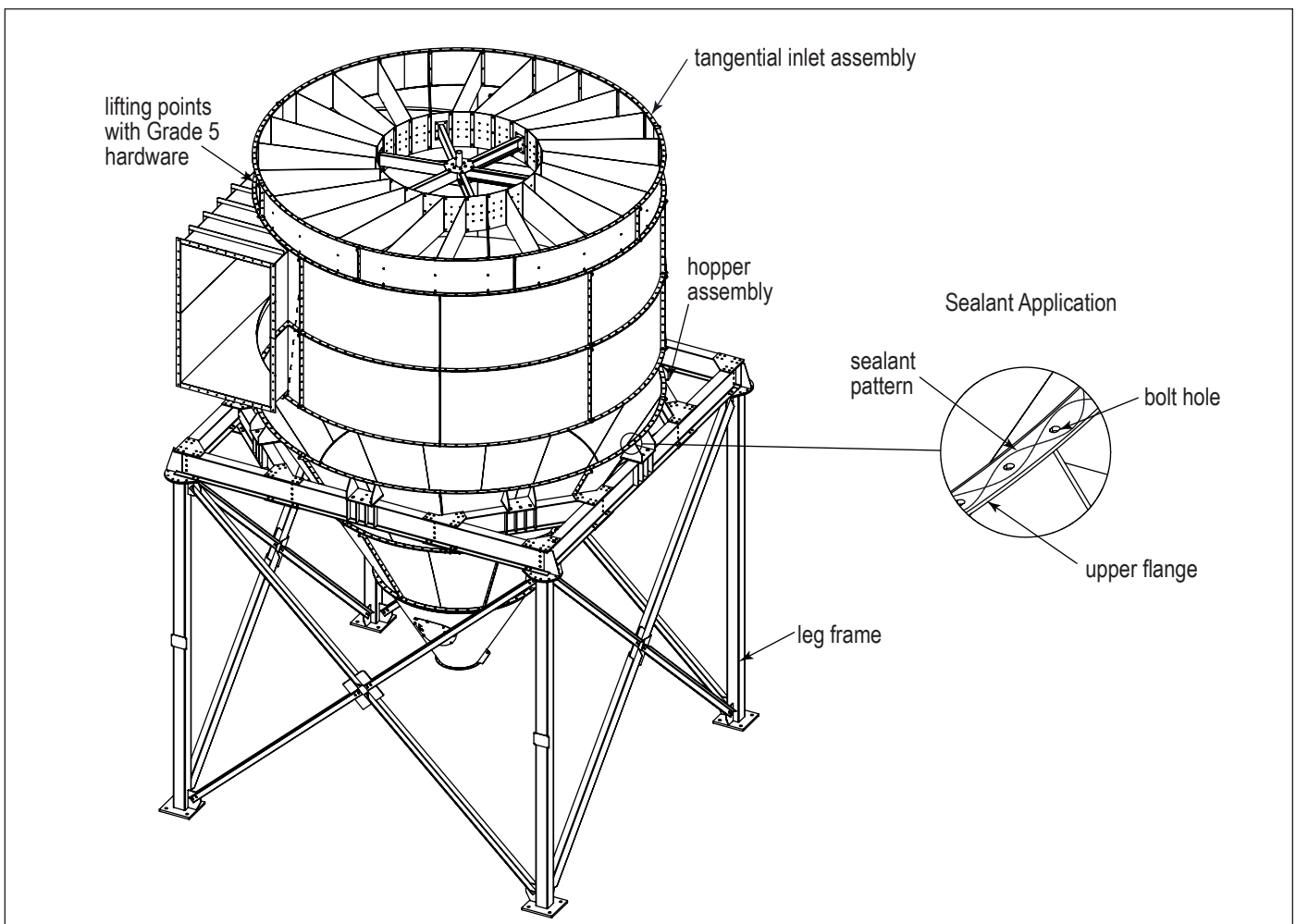

Tangential Inlet Assembly

5. Bag Section Assembly



Take precaution against pinching when handling and installing one body panel to the next.

Optional explosion vents must be located within the lowest section(s) of the Dirty-Air Plenum Assembly, BS4 if there is only one row of vents, or BS4 and BS3 if there are two rows of vents. Follow the arrangement shown on the assembly drawing included with the shipment of the collector. Errors in location of explosion relief panels may reduce their performance potentially causing a risk of severe personal injury and/or property damage.

1. Mount the first dirty-air plenum body panel (BS4) on the tubesheet. In this step and subsequent steps, the tubesheet will be used as a template to ensure correct alignment when joining subassemblies together. Align the outer bolt pattern of the dirty-air plenum body panel with the corresponding pattern on the tubesheet. Do not apply sealant between the dirty-air plenum body panel and the tubesheet.

Note: For collectors containing explosion vents, follow the panel arrangement as shown on the included dirty-air plenum 2SG Assembly Drawing.

2. Once two or more panels are side by side, apply sealant to the vertical flange of the panel within 1/8-in of the vertical flange's top and bottom edge as shown (see Body Panel Assembly) and press up against the adjoining panel. Align the holes and insert the 1/2-in bolt hardware. Keep hardware hand-tightened.
3. Finish joining the body panels until a complete body panel ring is assembled.

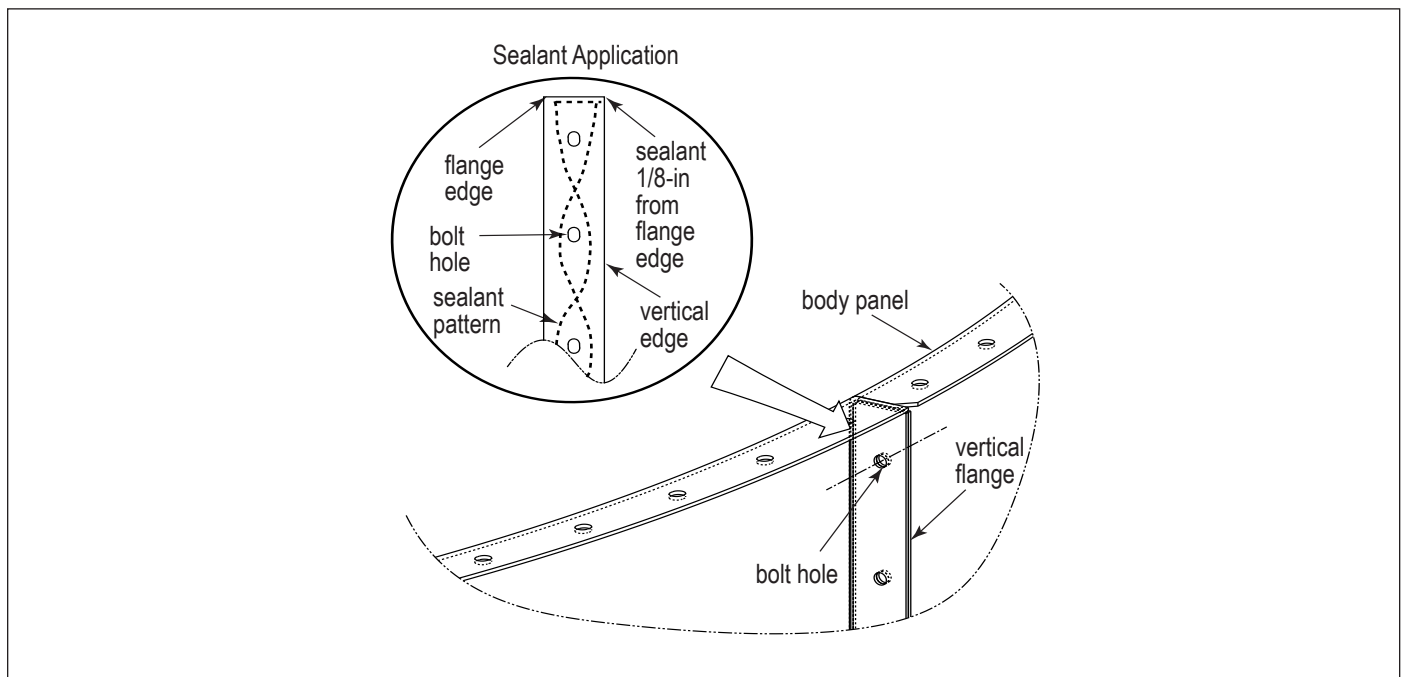

Body Panel Assembly

4. Move the completed first body panel ring assembly (with hand-tightened hardware) off the tubesheet onto a level area using standoffs to avoid ground contact.

Note: Lifting points bolt-on usage - use the provided bolt-on lifting points and grade 5 hardware when moving panels into position. Position the lugs such that excess swaying will be minimized. When lifting an assembly, use all four lugs with the backer plates attached.

5. Repeat Steps 1-4 for all rings of the dirty-air plenum (BS3, BS2 and BS1).
6. Apply sealant to the top flange of each body panel ring. See Detail B on Dirty-Air Plenum Assembly illustration.
7. Properly attach the lifting points with the Grade 5 hardware to each assembled ring. Lift the second ring (BS3) and set on top of the first ring (BS4). Lift third (BS2) and set on second (BS3) and lift the fourth (BS1) and set onto third (BS2).

Note: Vertical seams on each section must be spaced apart by a minimum of 4 bolt spaces. See Detail A on Dirty-Air Plenum Assembly illustration.

8. Tighten all hardware per the hardware table found in Tubesheet Assembly.
9. Set the completed dirty-air plenum assembly off to the side. Use standoffs under the flanges to keep them off grade.

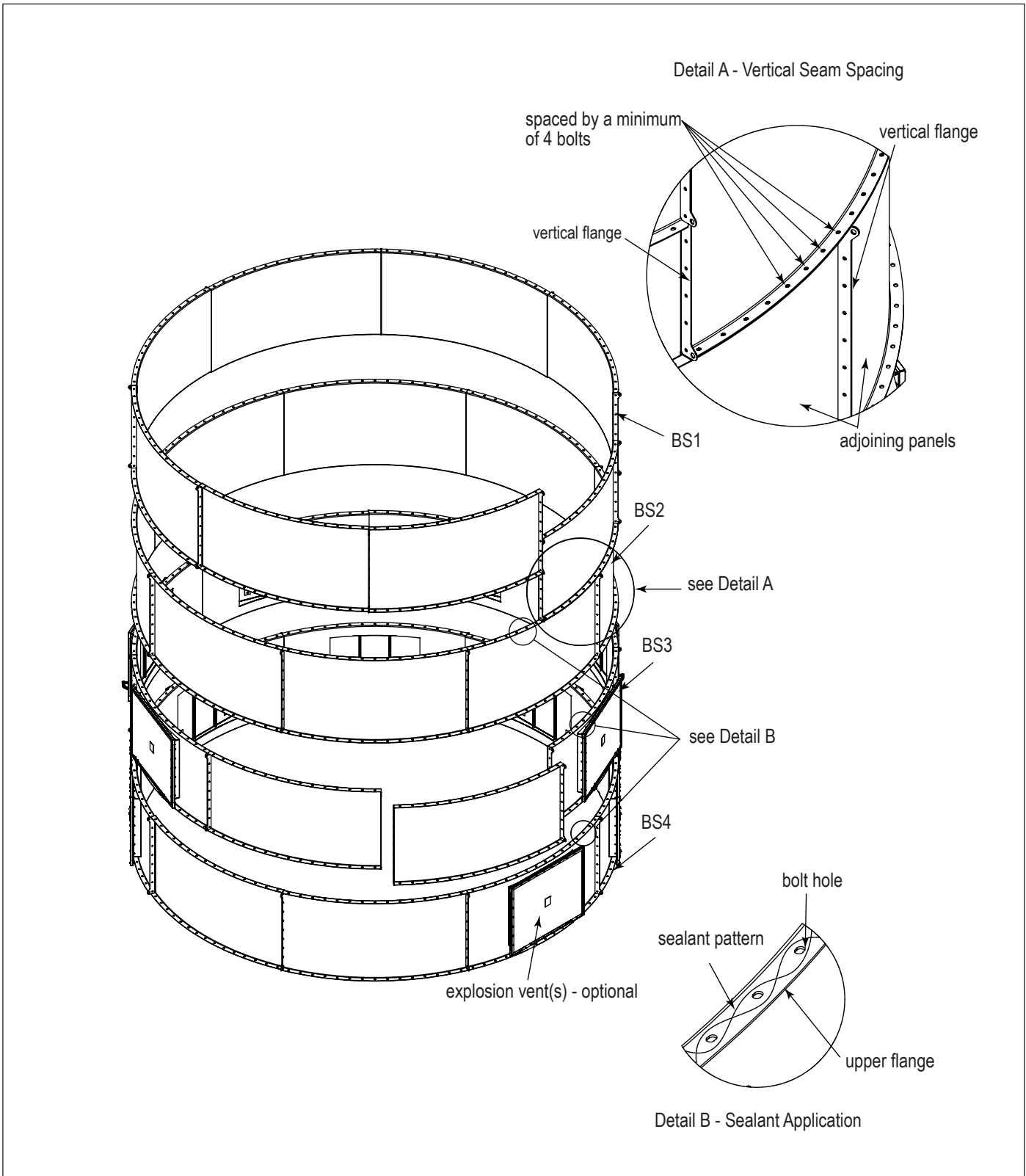

Dirty-Air Plenum Assembly 12-ft Bag Sections Shown

6. Clean-Air Access Plenum Assembly

- Place the clean-air access plenum panels onto the tubesheet. The tubesheet is used as a template to align the panels as in previous sections. Do NOT apply sealant between the tubesheet and the plenum panels.

NOTE: The clean-air access plenum includes the door frame panel and the cleaning system's H-frame mount panel. The panel containing the gussets "H-Frame Mount Pad" must be located 90 degrees either side of the door panel. These "H-Frame Mount Pads" will be used to support the cleaning drive H-Frame later in the installation sequence.

- Prior to setting an adjacent panel, apply sealant to all external vertical flanges within 1/8-in from flange edge as shown.
- Press vertical flanges together, align the holes, and insert the 1/2" bolt hardware. Keep hardware hand tightened.
- Repeat steps 2-3 for each panel until the entire clean-air access plenum ring is assembled.
- Tighten all bolts that have only been hand tightened up until this time.
- Remove assembly from tubesheet and set aside using standoffs to keep off grade.

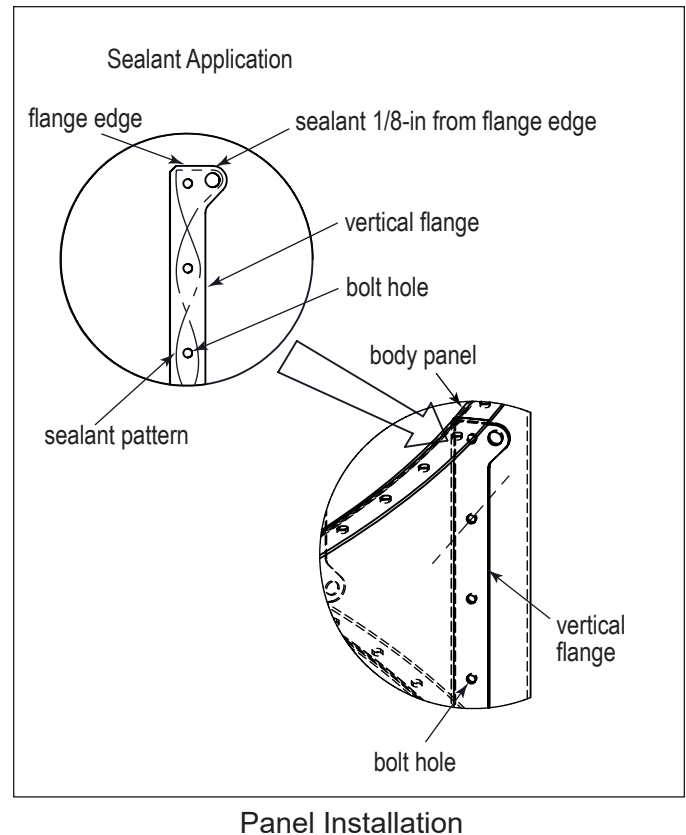

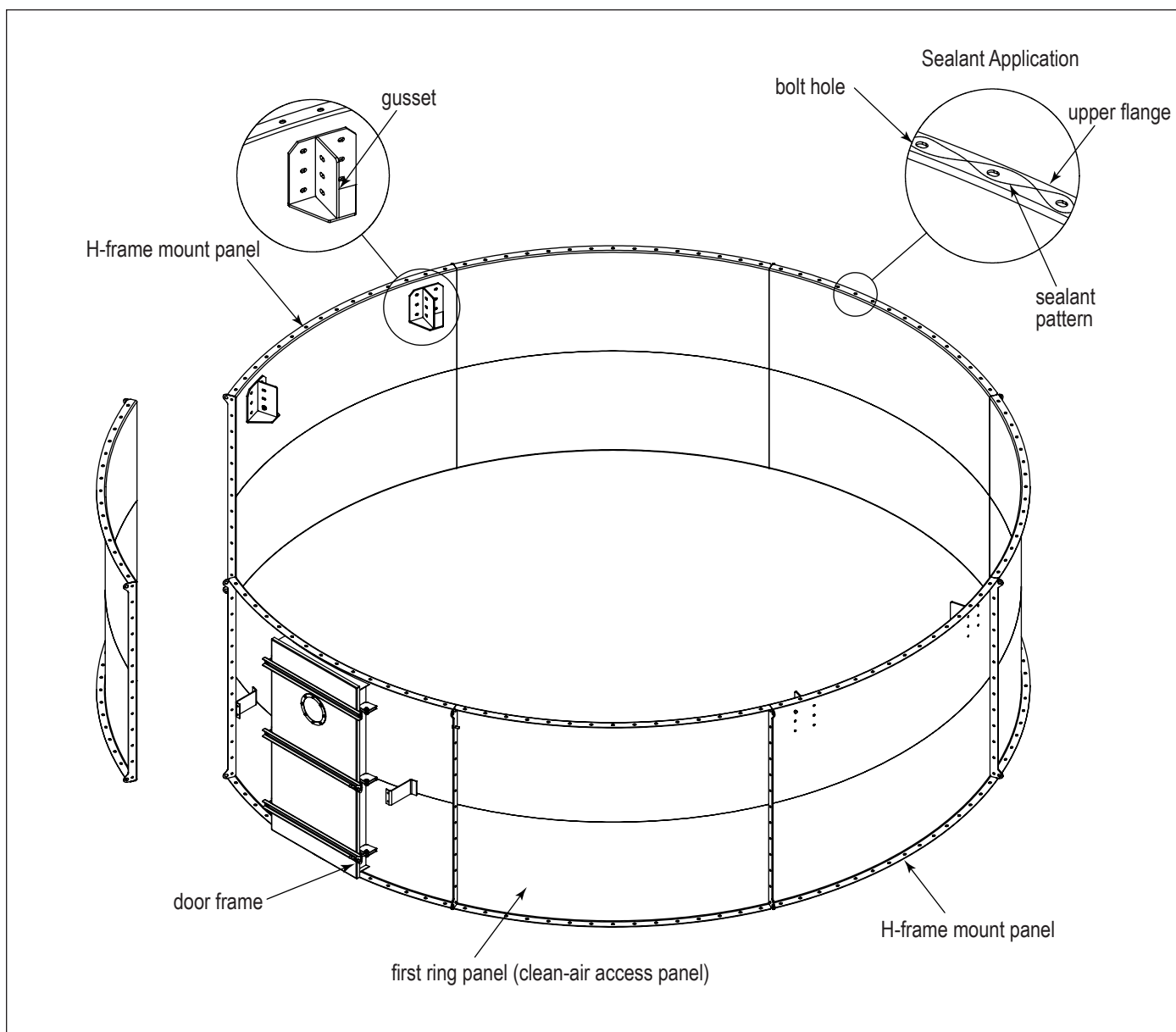

Clean-Air Access Plenum Assembly

7. Clean-Air Outlet Plenum and Roof Installation

1. Place the clean-air outlet plenum panels onto the tubesheet. The tubesheet is used as a template to align the panels as in previous sections. Do NOT apply sealant between the tubesheet and the plenum panels.
2. Prior to setting an adjacent panel, apply sealant to all external vertical flanges within 1/8-in from flange edge as shown.

NOTE: The placement of the outlet is critical to ensure proper orientation. Consult the original order or Donaldson supplied customer drawing to determine where to position the outlet.



Lifting lugs installed to the Clean- Air Outlet Plenum require Grade 8, 1/2-in diameter hardware (supplied with collector). Using any other grade may result in lifting lug failure.

3. Press vertical flanges together, align the holes, and insert the 1/2-in bolt hardware. Keep hardware hand tightened.
4. Repeat steps 2-3 for each panel until the entire clean-air outlet plenum ring is assembled.
5. Assemble roof onto clean-air outlet plenum.
6. After applying sealant to the flanges of the roof panels and to the top flange of the clean-air outlet plenum, place one of the top roof panels onto the top flange and bolt in place.
NOTE: Temporarily support the other end of the roof panel.
7. Install the remaining roof panels applying sealant to all flanges.
8. Place top cap piece onto top panels making sure there is sealant in place before placing the cap piece.
NOTE: It is imperative that sufficient sealant be used to create an air tight seal.
9. Tighten all bolts that have only been hand tightened up to this point. Reference the specification given previously in this manual.
10. Remove assembly from tubesheet and set aside using standoffs to keep off grade.

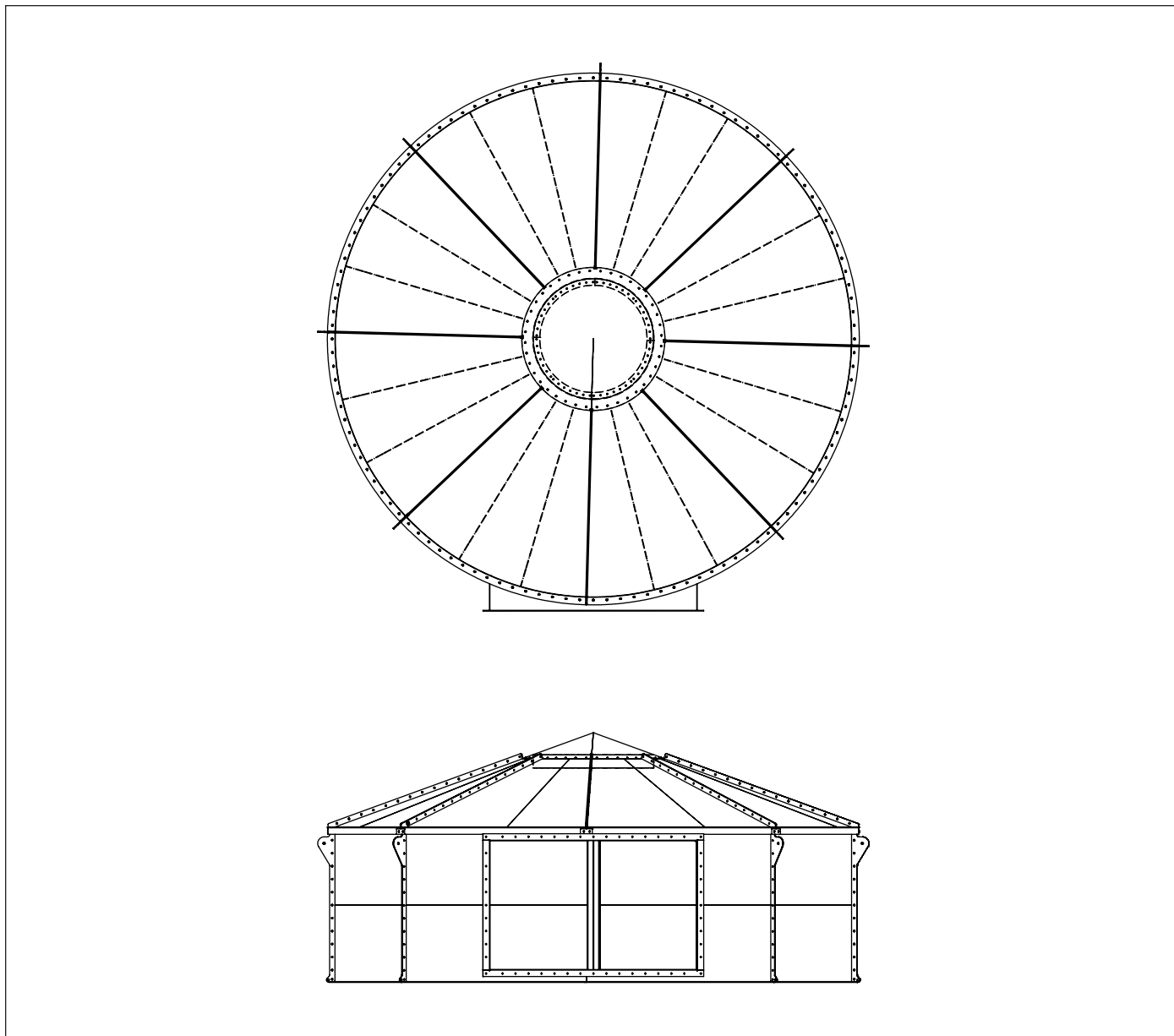

Roof Installation, 12-ft Bag Clean-Air Outlet Plenum Shown

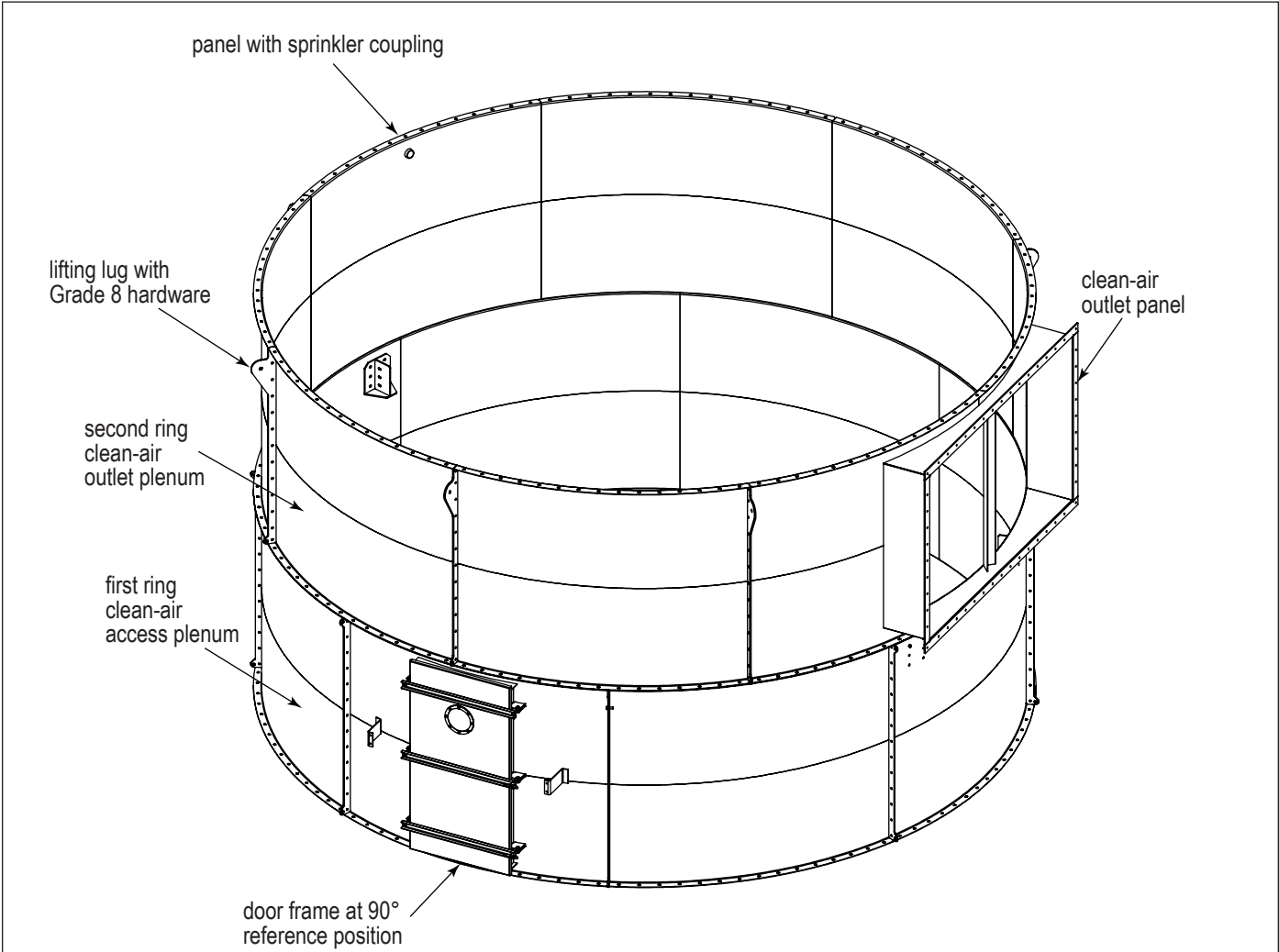

Clean-Air Plenum (12-ft Bag Clean-Air Plenum Shown)

8. Tubesheet Installation and Support Column

The tubesheet support column assists in leveling the tubesheet and supporting the tubesheet using the following steps.

1. Lift the tubesheet with the crane and attach the upper portion of the support column to the tubesheet center pipe using the provided 5/8 UNC x 6 threaded bolts. The holes are slotted so that the tubesheet stiffeners will come to rest onto the column plate.
2. Lift the tubesheet with the column onto the prepared dirty-air plenum bag section assembly.

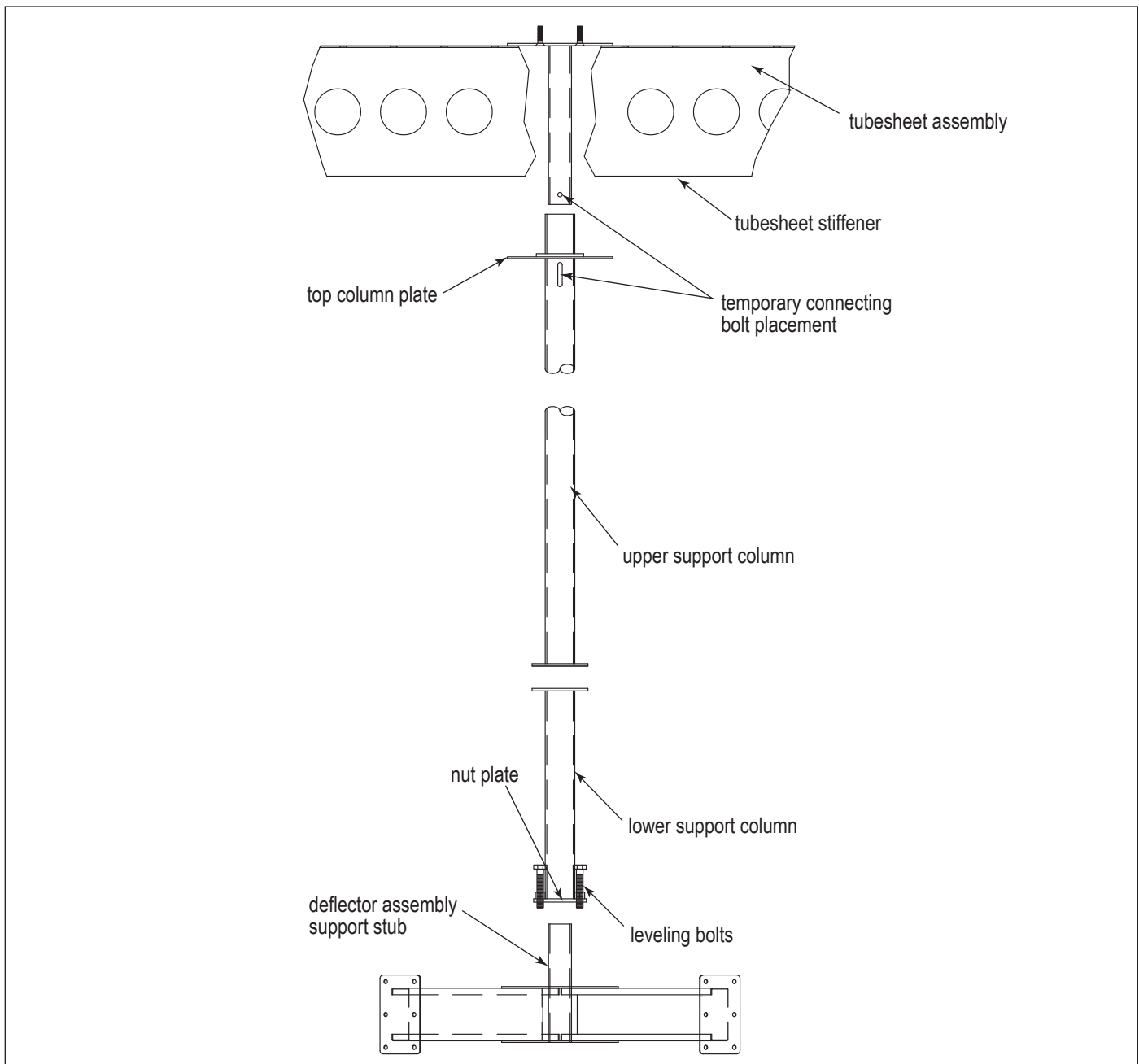

Tubesheet and Support Column

9. Lower Plenum Access Section Attachment and Internal Cleaning Assembly

NOTICE

Damage may occur to the rotating arms if interference is made while lifting or assembling body sections. Take precaution against pinching when handling and installing the cleaning system components.

Attach the clean-air access plenum assembly to the tubesheet and then install the filter cleaning system components. The cleaning assembly consists of the items shown in Cleaning Assembly illustration.

1. Prepare the tubesheet with sealant around the tubesheet perimeter.
2. Lift the clean-air access plenum assembly onto the tubesheet, making sure that the door is in the proper position.

NOTE: The placement of the access door is critical to ensure proper orientation. Consult the original order or Donaldson supplied customer drawing to determine where to position the access door.

Make sure that the Magnehelic Gauge connection in the clean-air access plenum assembly is close to the Magnehelic Gauge connection in the dirty-air plenum BS1 panel.
3. Install all bolts and tighten.
4. Lift the rotating elbow into the clean-air access plenum assembly and slip the shaft into bearing on tubesheet. Temporarily support the rotating elbow by placing wooden blocks between the tubesheet and the elbow base.
5. Lift the support channel "H-frame" with seal box into clean-air access plenum. Align internal bearing with rotating elbow shaft and lower the "H-frame" channel frame onto wall mounts. Install all bolts in wall mounts and hand tighten.
6. Using a level or a framing square on the rotating elbow flange, check that the rotating elbow shaft is vertical in all quadrants. Check the rotating elbow is centered in seal box opening.
7. Rotate the elbow by hand and check for any obstructions.

NOTE: The urethane seal should drag on elbow pipe.
8. Lift sweep arm(s) into access section and place on tubesheet. Attach the arm(s) to the rotating elbow.
9. Rotate the sweep arm assembly by hand and check for obstructions before attaching the chain.
10. Make sure that the cleaning arm has the same separation from the tubesheet in all four quadrants of 3 o'clock, 6 o'clock, 9 o'clock and 12 o'clock. To do this, place the cleaning arm in the 3 o'clock position. Measure the amount of sweep shoe rod that is extending above the cleaning arm. Measure how much the rod extends in the remaining 3 quadrants. If the difference between these four measurements are less than 1/2-in, no further adjustments are required. If these measurements are greater than 1/2-in, check to make sure the tubesheet is level and properly supported in the middle. If the difference between the four measurements is greater than 1/2-in, adjust the pillow block bearing or pillow block bearing shim.

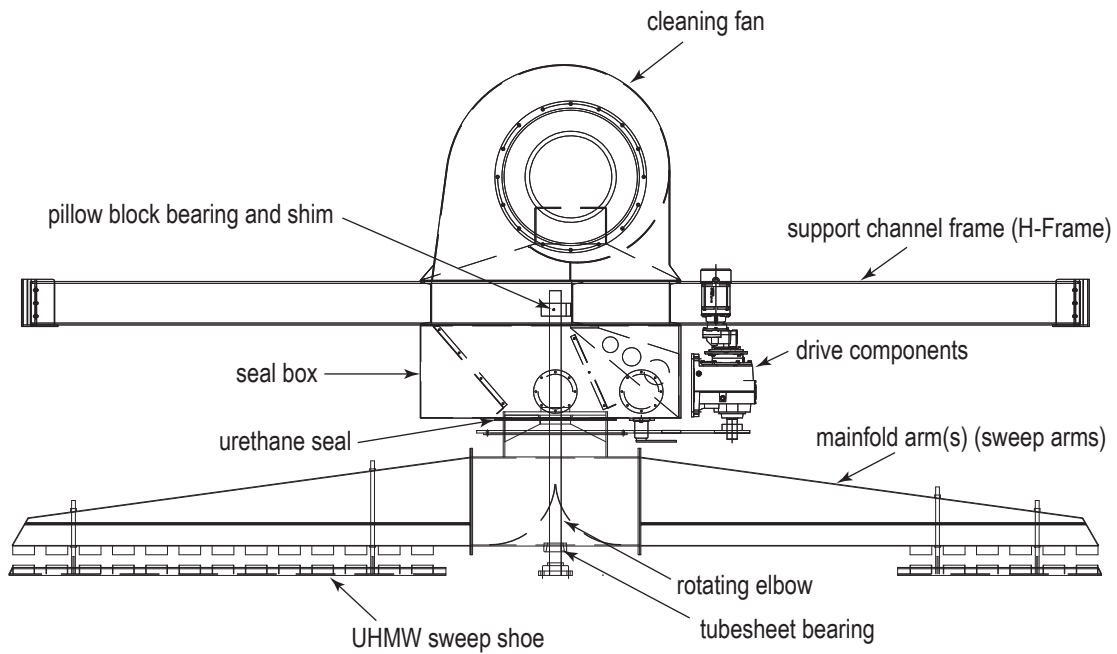

*Note: grease the pillow block bearing during regular maintenance

Cleaning Assembly

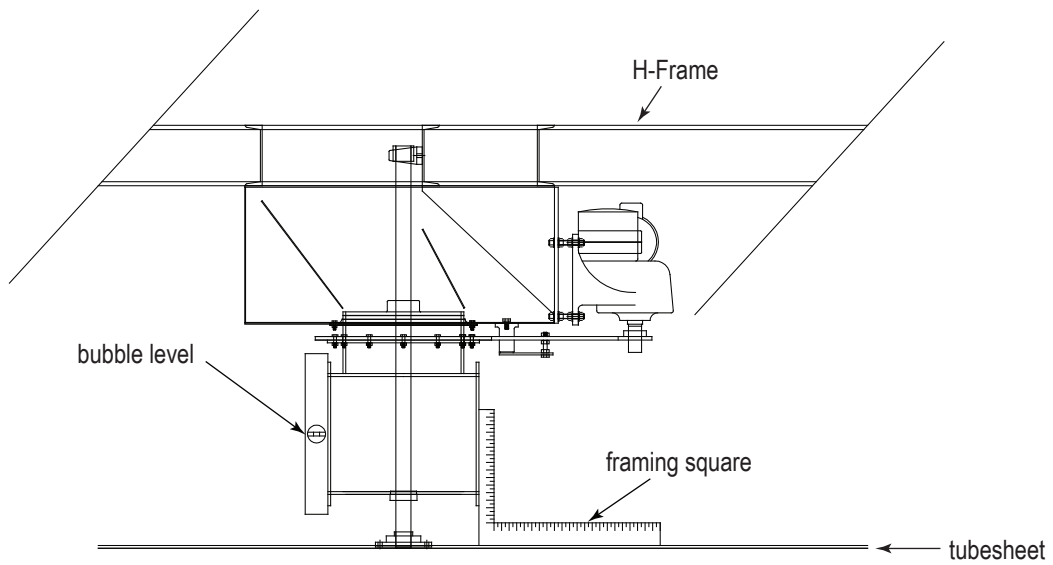

Measure Sweep Shoe

11. Once rotating elbow shaft is correctly aligned tighten all mount bolts and bearing set screws.
12. Install the drive chain on the sprocket as shown in the diagram below.

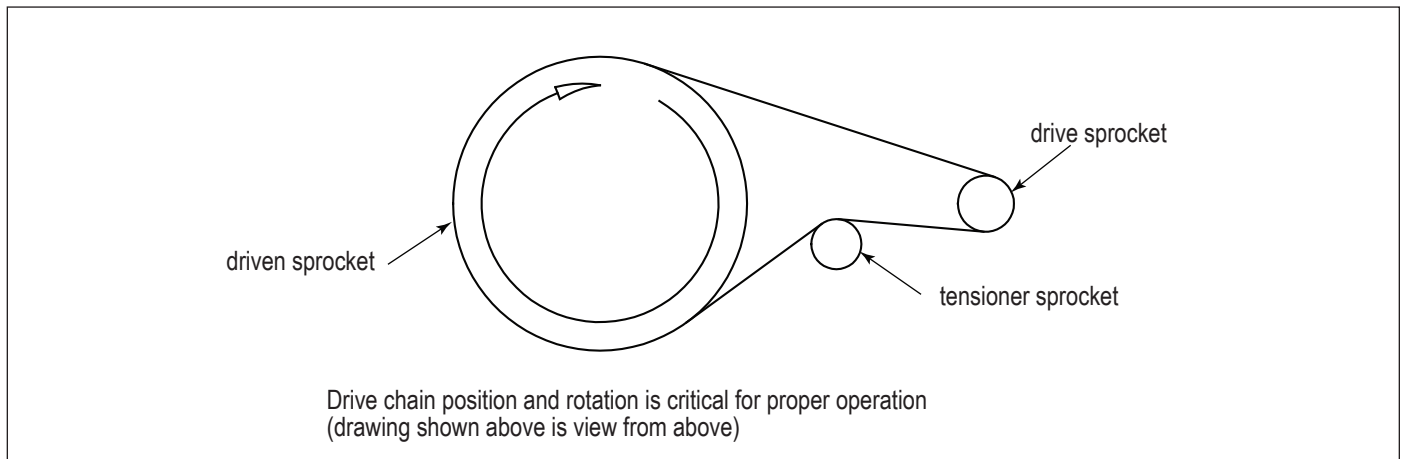

Drive Chain Installation

13. Prepare channels for placement of fan by applying a bead of silicone on the mating surface.
14. Lift fan into place and secure with provided bolts making sure to use the wedge washers on the channels.

10. Filter Bag and Cage Installation

1. From the clean-air plenum, carefully insert the snap band filter bag through the tubesheet with the closed end oriented downward.
2. Snap the bag in place with the tubesheet between the upper and lower rings on the filter bag collar shown in the Filter Bag and Cage Installation illustration.
3. Lower the filter cage into the bag. If the bag section is resting on the ground, the cages will not drop (seat) completely at this time. When the dirty-air plenum is lifted into place, the cages will drop to the correct position (fully seat).
4. Repeat steps 1-3 for all bags.

Note: The cleaning arm will need to be manually rotated to access some bags.

5. Once all bags are installed, ensure the cleaning arms rotate smoothly.

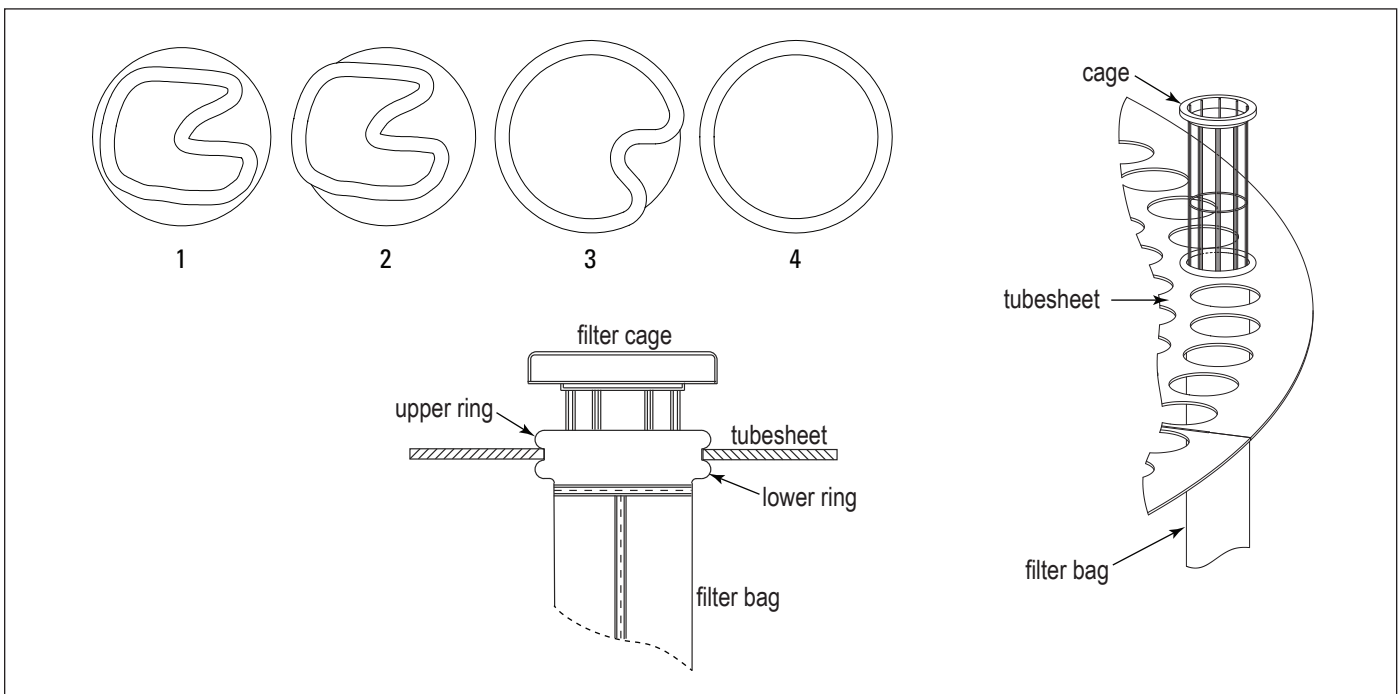

Filter Bag and Cage Installation

11. Clean-Air Outlet Plenum and Roof Section Attachment

The clean-air outlet plenum and roof assembly is ready to be installed.

1. Apply sealant to the top flange of the Clean-Air Access Plenum section.
2. Lift and secure the combined exhaust/roof section to the Lower Plenum Access section. Bolt into place.
3. Install all flange bolts and tighten.
4. Install the Magnehelic Gauge which is provided with a mounting plate at a remote location suitable for observation. Run two lines of the 1/4-in poly tubing provided from the plenum connections down to the gauge. Attach the tubing to the filter at the section flanges with the clips provided to keep it in place. Follow Field Assembly Instructions provided on the Magnehelic Pack drawing shipped with the collector.

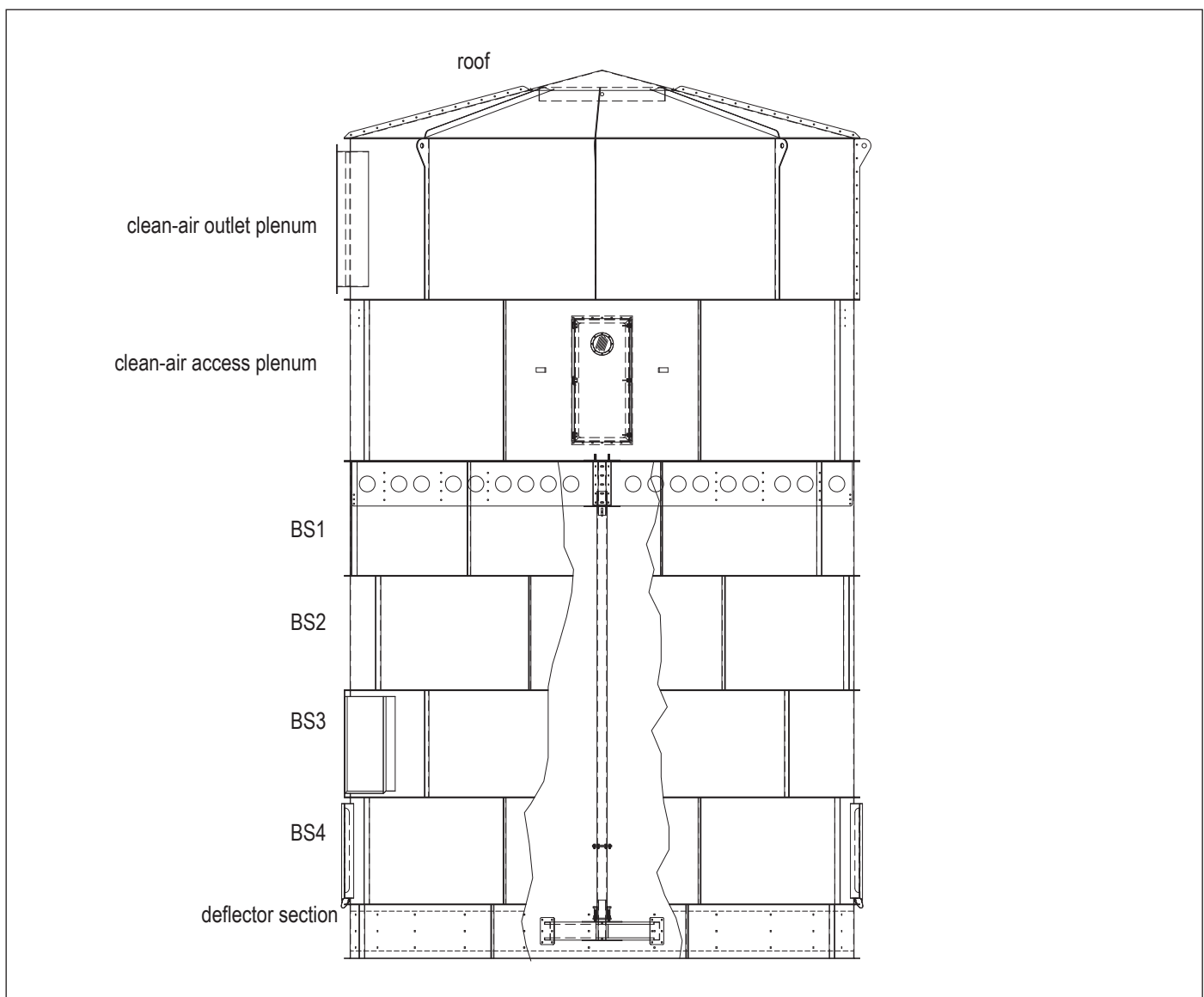

Clean-Air Plenum Assembly

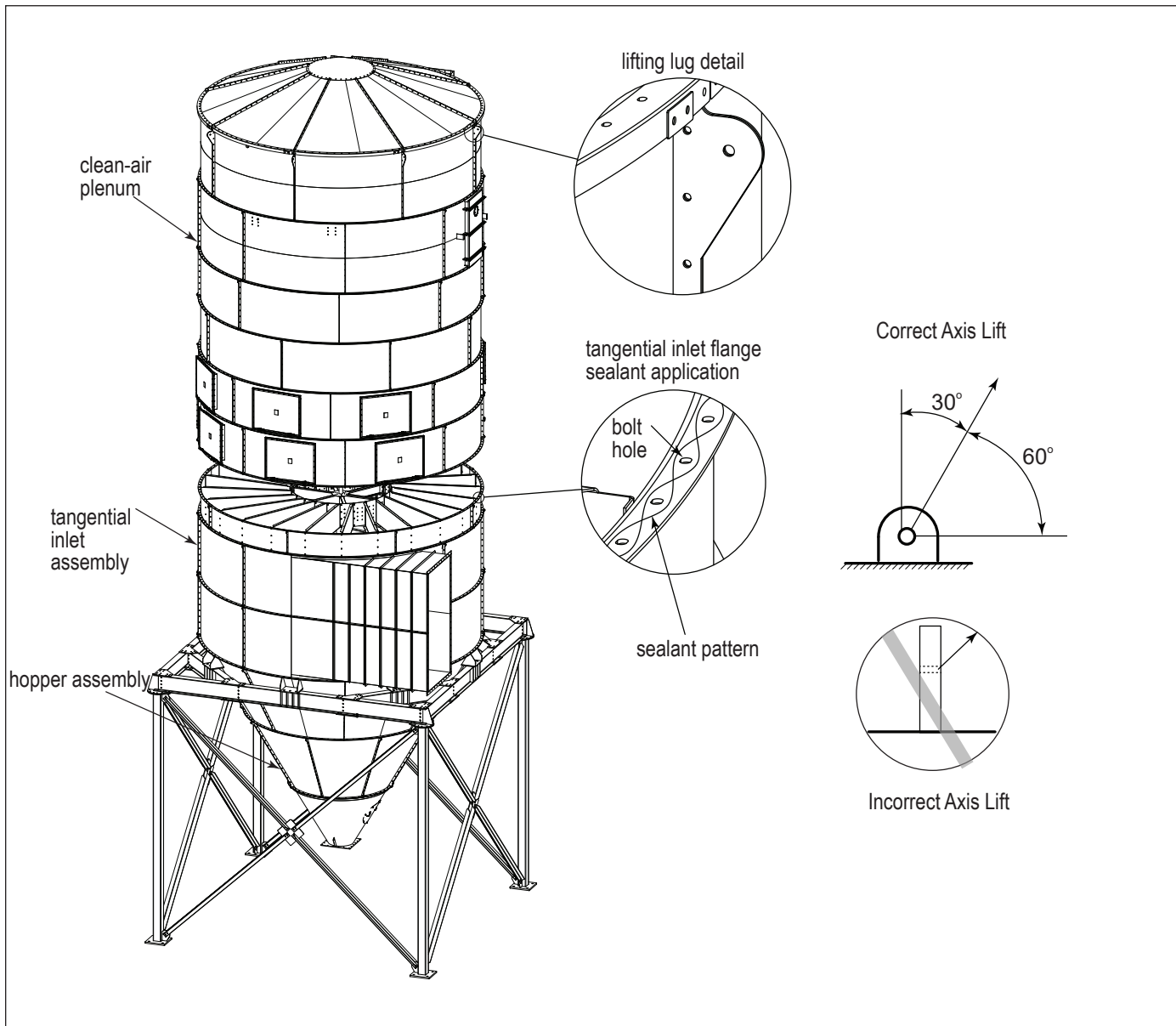

Collector Assembly

12. Exhaust Ducting

Depending on the ducting configuration, some of the pieces of ducting can be attached to the clean-air outlet exhaust flange and lifted at the same time. Any ducting that is attached to the clean-air outlet exhaust must be sufficiently supported along its length so as not to damage the collector.

13. Ladder/Platform Installation

1. Attach the knee braces to the platform assembly shown on drawing(s) shipped with collector.
2. Lift the platform assembly into position.
3. Remove the hardware located where the platform assembly and knee braces will connect to the body panel flanges.
4. Position the platform assembly. Reinstall and tighten the existing hardware including the bolted connections for the platform railing and knee braces.
5. Assemble the entire ladder sub-assembly per the drawing provided. Temporarily bolt the adjustable, bottom angle anchors to the highest position.
6. If applicable, install the lower intermediate ladder support to the leg pack following the drawing provided.
7. Lift the completed ladder assembly into position and fasten to the platform assembly.
8. Install the remaining intermediate support(s). Match drill the ladder assembly per the drawing provided and attach to the support.
9. Loosen the bottom ladder section and position it to touch the collector foundation. Concrete anchors provided by the process owner will be required to complete this connection.

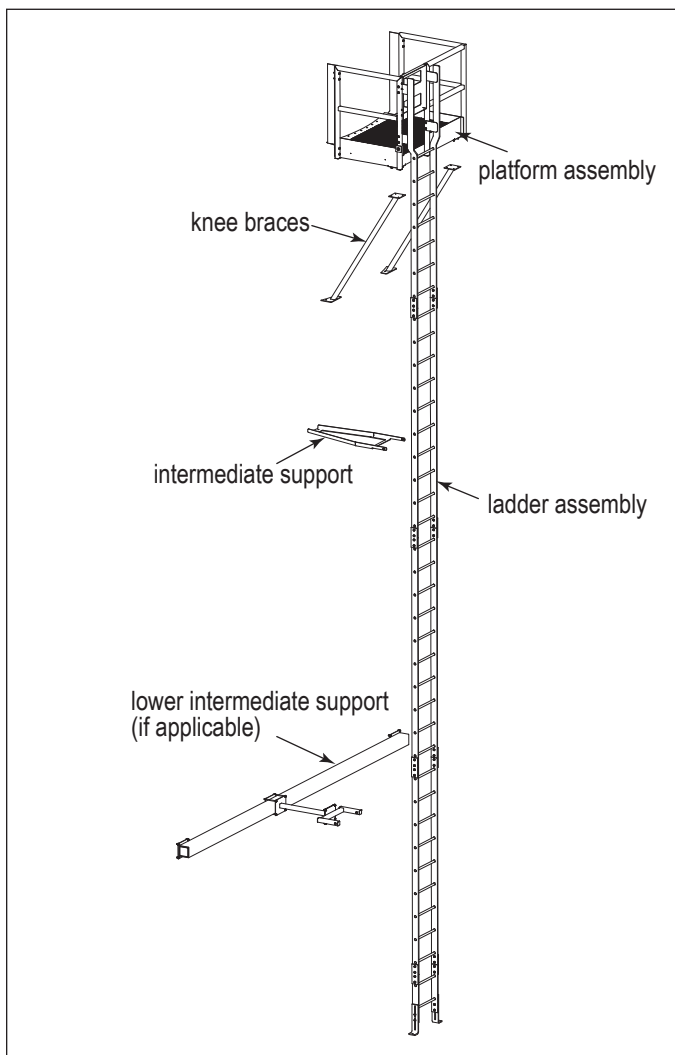

Platform Installation

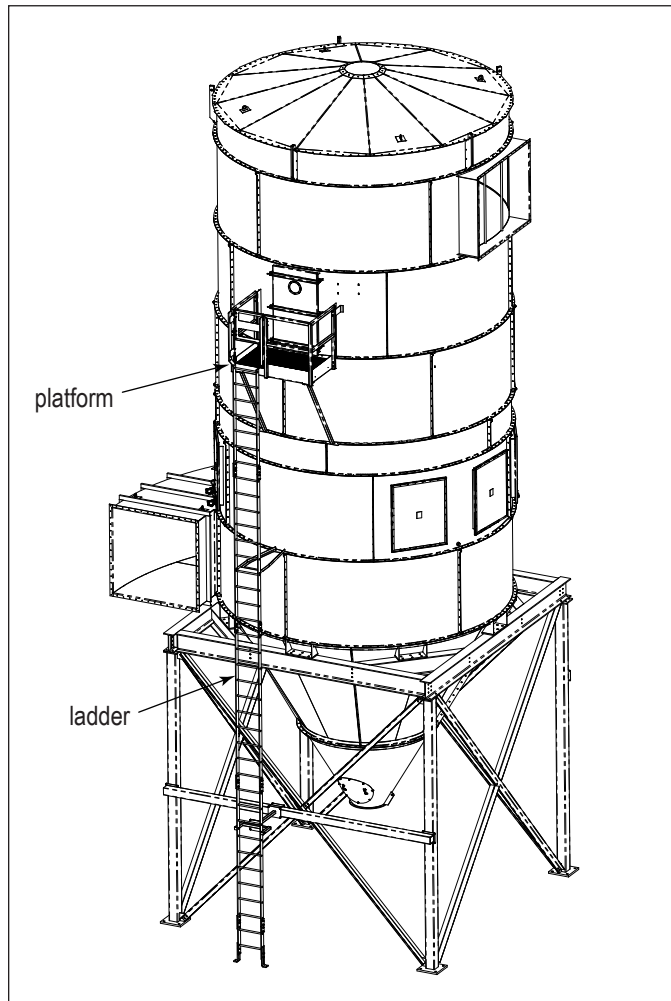

Ladder Installation

14. Additional Ducting

After collector is completely erected the rest of the ducting may be connected. It is important to ensure that the ducting is adequately supported and that the weight is not entirely on the collector.

15. Material Discharge Mechanism

The material discharge device flange should be prepared with sealant to ensure an air tight seal. Lift the device into position and bolt into place. Depending on the accessory, additional support may be required.

16. Electrical Connections

All electrical connections are the responsibility of the process owner. Follow all local and national electrical codes when installing service. Any wiring on the interior of the collector may need to be rated for explosive environments. Consult your local codes.

17. Fire Mitigation System

NOTICE

Consult with local authorities when installing fire control systems on dust collection equipment.

Sprinkler couplings are provided for the convenience of fire control system installers. The fire control system installer shall make their own decisions on the appropriate location of fire control system components.

18. Structural Connections

Before placing collector into service it is important that all structural connections be inspected for proper torque. It is recommended that all structural bolts be checked and re-tightened if necessary.

19. Electrical and Mechanical Connections

Before placing collector into service it is important that all electrical connections are inspected and approved.

Start-Up/Commissioning Collector

Instruct all personnel on safe use and maintenance procedures.



Electrical work during installation,, service or maintenance must be performed by a qualified electrician and comply with all applicable national and local codes.

Turn power off and lock out all power before performing service or maintenance work.

Turn compressed air supply off, bleed and lock out lines before performing service or maintenance work.

Check that the collector is clear and free of all debris before starting.

Do not install in classified hazardous atmospheres without an enclosure rated for the application.

Once the LP has been placed, anchored, connected to power and ducts attached to the appropriate equipment, the collector is ready for initial start-up and commissioning.

1. Check all electrical connections for tightness and contact.
2. Check for proper rotation as noted on the fan housings.



Do not look into fan outlet to determine rotation. View the fan rotation through the back of the motor.

Check that the exhaust plenum is free of tools or debris before checking blower/fan rotation.

Stand clear of exhaust to avoid personal injury.

Do not interchange a power lead with the ground wire. Severe personal injury and/or property damage may result.

3. Confirm the cleaning system fan rotation is correct.
 - a. Bump” the fan to initiate rotation.
 - b. As the fan is winding down (unpowered) compare fan rotation to the rotation label (located on fan housing) direction.
4. If the fan rotation is reversed, correct the rotation.

To reverse rotation, single-phase power supply: Follow manufacturer’s instructions on the motor’s nameplate.

To reverse rotation, three-phase power supply: Switch any two leads on the motor junction box.

- a. Turn off the collector and Lock-Out all energy sources.
- b. Within the junction box, swap the connection location of two power leads on the terminal block, making certain not to swap a power lead and the ground wire.

5. Confirm the cleaning arm rotation is correct.
 - a. Activate the cleaning arm drive motor to initiate rotation.
 - b. Observe arm rotation relative to the rotation label located on top of the sweep arm.
6. If the arm rotation is reversed, correct the rotation.
 - a. Turn off the collector and Lock-Out all energy sources.
 - b. Within the junction box, swap the connection location of two power leads on the terminal block, making certain not to swap a power lead and the ground wire.
7. Ensure the Magnehelic gauge is properly installed and functioning. Refer to the included print for additional instruction.
8. Ensure all collector access panels and doors are sealed and secure.
9. Check that the hopper discharge gate is open and the storage container is properly sealed, if equipped.
10. Check and remove all loose items in or near the inlet and outlet of the collector.
11. Check that all remote controls are properly wired and all service switches are in the OFF position.
12. Ensure all bags and cages are installed and secure.
13. Ensure fire mitigation system water is installed and functioning correctly, if present.
14. Check that all optional accessories are installed properly and secured.

Decommissioning Collector

Once the collector has reached the end of operational life it will need to be decommissioned.



During decommissioning, there is potential for exposure to the dust in the collector. Most dusts present safety and health hazards that require precautions. Wear eye, respiratory, head, and other protection equipment suitable for the type of dust when performing any decommissioning activities.

LOCK-OUT all energy sources prior to performing any decommissioning activities on the equipment.

Electrical service must be performed by a qualified electrician.

Disconnection of ducts must be performed by a qualified tinsmith or contractor.

1. Follow the typical shut-down sequence steps located in the operation section to remove as much contaminant from collector as possible.
2. Lock-Out all energy sources.
3. Remove all filters from the collector and dispose of in a suitable fashion for the dust in the collector. (See Filter Replacement for removal instructions).
4. Disconnect electrical power from the collector and remove any associated conduit or hardware from the exterior of the collector.
5. Disconnect all ducts from the collector.
6. Shut off and remove fire mitigation system.
7. Proceed to disassemble collector by removing sub-assemblies in the reverse order of the steps given in Appendix A.
Note: The clean-air plenum, dirty-air plenum, tubesheet, H-frame and cleaning assembly may be removed in separate steps instead of as one unit.
8. Once all cross-bracing has been taken down, remove anchor bolts and lower leg pack columns.
9. Secure all collector components to a suitable transport carrier and transport to a disposal site suitable for the dust in the collector.

Product Information (Process Owner to complete and retain for your records)

Model Number _____	Serial Number _____
Ship Date _____	Installation Date _____
Filter Type _____	
Collected Dust _____	
Dust Properties: Kst _____	Pmax _____ MIE _____ MEC _____
Accessories _____	
Other _____	

Donaldson Industrial Air Filtration Warranty

Donaldson warrants to the original purchaser only that the Goods will be free from defects in material and manufacture for the applicable time periods stated below: (1) Major structural components for a period of ten (10) years from the date of shipment; (2) Non-Structural, Donaldson-built components and accessories including Donaldson Airlocks, TBI Fans, TRB Fans, Fume Collector products, Donaldson built electrical control components, and Donaldson-built Afterfilter housings for a period of twelve (12) months from date of shipment; and (3) Donaldson-built filter elements for a period of eighteen (18) months from date of shipment.

Buyer is solely responsible for determining if goods fit Buyer's particular purpose and are suitable for Buyer's process and application. Seller's statements, engineering and technical information, and recommendations are provided for the Buyer's convenience and the accuracy or completeness thereof is not warranted. If, after Seller receives written notice, within the warranty period, that any goods allegedly do not meet Seller's warranty, and Seller, in its sole discretion, determines that such claim is valid, Seller's sole obligation and Buyer's exclusive remedy for breach of the foregoing warranty or any Seller published warranty, will be, at Seller's option, either: (i) repair or replacement of such goods or (ii) credit or refund to Buyer for the purchase price from Seller. In the case of repair or replacement, Seller will be responsible for the cost of shipping the parts but not for labor to remove, repair, replace or reinstall the allegedly defective goods. Refurbished goods may be used to repair or replace the goods and the warranty on such repaired or replaced goods shall be the balance of the warranty remaining on the goods which were repaired or replaced. Any repair or rework made by anyone other than Seller is not permitted without prior written authorization by Seller, and voids the warranty set forth herein. Seller warrants to Buyer that it will perform services in accordance with the Sales Documents using personnel of required skill, experience and qualifications and in a professional and workmanlike manner in accordance with generally recognized industry standards for similar services. With respect to any services subject to a claim under the warranty set forth above, Seller shall, in its sole discretion, (i) repair or re-perform the applicable services or (ii) credit or refund the price of such services at the pro rata contract rate and such shall be Seller's sole obligation and the exclusive remedy for breach of the foregoing warranty on services. Products manufactured by a third party ("Third Party Product") may constitute, contain, be contained in, incorporated into, attached to or packaged together with, the goods. Buyer agrees that: (a) Third Party Products are excluded from Seller's warranty in this Section 7 and carry only the warranty extended by the original manufacturer, and (b) Seller's liability in all cases is limited to goods of Seller's design and manufacture only. EXCEPT FOR SELLER'S WARRANTY OF TITLE TO THE GOODS, SELLER EXPRESSLY DISCLAIMS AND EXCLUDES ALL OTHER WARRANTIES WHATSOEVER, WHETHER, EXPRESSED OR IMPLIED, ORAL, STATUTORY, OR OTHERWISE, INCLUDING BUT NOT LIMITED TO MERCHANTABILITY, FITNESS FOR A PARTICULAR PURPOSE, NON-INFRINGEMENT OF THIRD PARTY INTELLECTUAL PROPERTY AND ANY WARRANTIES ARISING FROM TECHNICAL ADVICE OR RECOMMENDATIONS, COURSE OF DEALING OR OF PERFORMANCE, CUSTOM OR USAGE OF TRADE. Seller's obligations do not cover normal wear and tear or deterioration, defects in or damage to any goods resulting from improper installation, accident or any utilization, maintenance, repair or modification of the goods, or any use that is inconsistent with Seller's instructions as to the storage, installation, commissioning or use of the goods or the designed capabilities of the goods or that, in its sole judgment, the performance or reliability thereof is adversely affected thereby, or which is subjected to abuse, mishandling, misuse or neglect or any damage caused by connections, interfacing or use in unforeseen or unintended environments or any other cause not the sole fault of Seller, and shall be at Buyer's expense. Seller's warranty is contingent upon the accuracy of all information provided by Buyer. Any changes to or inaccuracies in any information or data provided by Buyer voids this warranty. Seller does not warrant that the operation of the goods will be uninterrupted or error-free, that the functions of the goods will meet Buyer's or its customer's requirements unless specifically agreed to, or that the goods will operate in combination with other products selected by Buyer or Buyer's customer for its use.

The terms of this warranty may only be modified by a special warranty document signed by a Director, General Manager or Vice President of Donaldson. To ensure proper operational performance of your equipment, use only genuine Donaldson replacement parts.

This Product is provided subject to and conditioned upon Donaldson's Terms of Sale ("Terms"), a current copy of which is located at termsofsale.donaldson.com. These Terms are incorporated herein by reference. By purchasing or using this Product, the user accepts these Terms. The Terms are available on our website or by calling our customer service line at 1-800-365-1331.

Significantly improve the performance of your collector with genuine Donaldson Torit replacement filters and parts. **Call Donaldson Torit at 800-365-1331.**

Important Notice: Many factors beyond the control of Donaldson can affect the use and performance of Donaldson products in a particular application, including the conditions under which the product is used. Since these factors are uniquely within the user's knowledge and control, it is essential the user evaluate the products to determine whether the product is fit for the particular purpose and suitable for the user's application. All products, product specifications, availability and data are subject to change without notice, and may vary by region or country.



Donaldson Company, Inc.
Minneapolis, MN
donaldson.com • shop.donaldson.com

North America
Email: donaldson@donaldson.com
Phone: (USA): +1-800-365-1331 • (MX): +1-800-343-3639

Australasia
Email: marketing.australia@donaldson.com
Phone: +61-2-4350-2000
Toll Free: (AU) +1800-345-837 • (NZ) +0800-743-387

China
Email: info.cn@donaldson.com
Phone: +86-400-820-1038

Donaldson Europe B.V.B.A.
Email: IAF-europe@donaldson.com
Phone: +32-16-38-3811

India
Email: info.dfis@donaldson.com
Phone: +91-124-4807-400 • +1-800-103-5018

Japan
Email: jp-ndl.ifswb@donaldson.com
Phone: +81-42-540-4112

Korea
Email: iaf-kr@donaldson.com
Phone: +82-2-517-3333

Latinoamerica
Email: IndustrialAir@donaldson.com
Phone: +52-449-300-2442

South Africa
Email: SAMarketing@donaldson.com
Phone: +27 11 997 6000

Southeast Asia
Email: IAF.SEA@donaldson.com
Phone: (65) 63117373

IOM AG8589301 (ENG), Revision 1 (August 2020) ©2019 Donaldson Company, Inc.
Donaldson, Torit, Dura-Life, and the color blue are marks of Donaldson Company, Inc. All other marks belong to their respective owners.