

Installation and Operation Manual

WSO Mist Collector Machine-Mountable Models WSO 10, 15, and 20

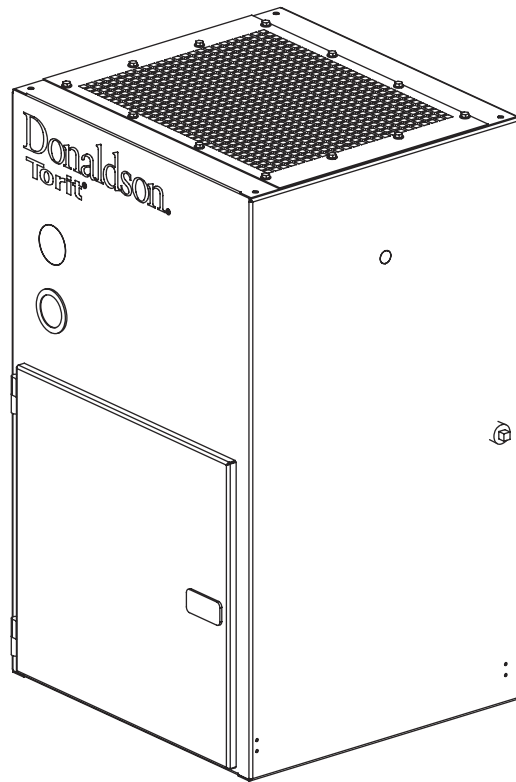

Throughout this manual statements indicating precautions necessary to avoid equipment failure are referenced in a **Note**. Statements indicating potential hazards that could result in *personal injury* or *property damage* are referenced in a **Caution!** box.



This manual is property of the owner. Leave with the unit when set-up and start-up are complete. Donaldson Company reserves the right to change design and specifications without prior notice.

WARNING

Process owners/operators have important responsibilities relating to combustible hazards. Process owners/operators must determine whether their process creates combustible dust, fume, or mist. If combustible dust, fume, or mist is generated, process owners/operators should at a minimum:

- Comply with all applicable codes and standards. Among other considerations, current NFPA standards require owners/operators whose processes involve potentially combustible materials to have a current Hazard Analysis, which can serve as the foundation for their process hazard mitigation strategies.
- Prevent all ignition sources from entering any dust collection equipment.
- Design, select, and implement fire and explosion mitigation, suppression, and isolation strategies that are appropriate for the risks associated with their application.
- Develop and implement maintenance work practices to maintain a safe operating environment, ensuring that combustible dust, fume, or mist does not accumulate within the plant.

Donaldson recommends process owners/operators consult with experts to insure each of these responsibilities are met.

As a manufacturer and supplier of Industrial Filtration Products, Donaldson can assist process owners/operators in the selection of filtration technologies. However, process owners/operators retain all responsibility for the suitability of fire and explosion hazard mitigation, suppression, and isolation strategies. Donaldson assumes no responsibility or liability for the suitability of any fire and/or explosion mitigation strategy, or any items incorporated into a collector as part of an owner/operators hazard mitigation strategy.

Improper operation of a dust control system may contribute to conditions in the work area or facility that could result in severe personal injury and product or property damage. Check that all collection equipment is properly selected and sized for the intended use.

DO NOT operate this equipment until you have read and understand the instruction warnings in the Installation and Operations Manual. For a replacement manual, contact Donaldson Torit.

This manual contains specific precautionary statements relative to worker safety. Read thoroughly and comply as directed. Discuss the use and application of this equipment with a Donaldson Torit representative. Instruct all personnel on safe use and maintenance procedures.

Data Sheet

Model Number _____	Serial Number _____
Ship Date _____	Installation Date _____
Customer Name _____	
Address _____	

Filter Type _____	
Accessories _____	
Other _____	

Contents

Caution Statements.....	2	Collector Stand Installation	16
Data Sheet	3	Floor Mount Stand Installation	18
Description	4	Inlet Hopper with Flex-Duct Installation ...	19
Purpose and Intended Use	4	P-Trap Installation	20
Operation	5	Electrical Connection.....	21
Inspection on Arrival.....	6	Motor Starter Control Box	21
Installation Codes and Procedures.....	6	Optional Equipment	22
Installation.....	6	HEPA/95% DOP Filter	22
Site Selection, Grade-Mounted Units	6	Retrofit Kit Field Installation.....	22
Site Selection, Ceiling-Mounted Units.....	7	Latch and Afterfilter Installation	22
Unit Location	7	Afterfilter Pressure Gauge Installation	23
Electrical Wiring	8	Sprinkler Installation	24
Rigging Instructions.....	8	Drain Collection Container.....	25
Suggested Tools and Equipment.....	8	Preliminary Start-Up Check	26
Hoisting Information	8	Service Information	26
Standard Equipment	10	Operational Checklist	26
General Installation	10	Filter Cleaning and Replacement	28
Flush Mount Installation	12	Primary Filter Replacement.....	28
Flanged Inlet Hopper Installation	12	Final Filter Replacement	30
Ceiling Mount Installation.....	13	P-Trap Service	31
Machine Center Mount Installation.....	14	P-Trap with Y Strainer Service.....	31
		Drain Collection Container.....	32
		Troubleshooting.....	33
		Service Notes	35
		Warranty	40



This manual contains specific precautionary statements relative to worker safety. Read thoroughly and comply as directed. Discuss the use and application of this equipment with a Donaldson representative. Instruct all personnel on safe use and maintenance procedures.

Minihelic® is a registered trademark of Dwyer Instruments, Inc.

Data Sheet

Model Number _____ Serial Number _____

Ship Date _____ Installation Date _____

Customer Name _____

 Address _____

Filter Type _____

Accessories _____

 Other _____

Description

Designed for versatility, the WSO (Water, Smoke, and Oil) mist collector is specifically engineered for water-soluble, smoke, and oil-based mist applications. WSO mist collector, Machine-Mountable Models WSO 10, 15, and 20 collect airborne mist such as oil, water-soluble, semi-synthetic and synthetic coolant from machining operations. Two stages of filtration, plus an optional HEPA or 95% DOP filter, provide a cleaner, healthier work environment as well as a more cost effective means of mist collection. With airflow capacities up to 1200 cfm for the WSO 10, 15, and 20, the WSO is a strategic component to meeting industrial and government air-quality standards. The high efficiency filter cartridges allow air and coolants to be recycled.

Designed to increase the versatility of the unit, a variety of filter media specifically designed for mist collection is a standard offering on the product line. The WSO model number (10, 15, or 20) indicates the height of the primary filter in inches for that particular model. For examples, the WSO 15 contains a 15 inch tall primary filter. The primary filter is uniquely designed for either water-based coolants, straight oils, or thermally-generated smoky applications. Standard options include drain collection containers, P-traps, adjustable floor mounting stands, and afterfilters.

The WSO machine-mountable unit is powered by a blower and motor mounted in the filter cabinet.

Purpose and Intended Use

Airborne mist is small droplets of metalworking fluids suspended in the air. Metalworking fluids include straight oils, water-soluble coolants, semi-synthetic and synthetic coolants. These fluids perform a variety of functions such as lubricating or cooling the part or the tool, flushing chips away from the part, and suppressing dust and smoke.

Mist is created in two ways: mechanical action or thermal effects. Mechanical action involves coolant used for light lubrication and generally creates mist greater than one micron in size. Thermal effects occur when heat vaporizes the coolant, the vapor cools and recondenses into a mist. Thermal effects create mist from 0.01 to 1 micron in size. Other contaminants, such as dust from the part or the tool or smoke from the vaporization of the oil or coolant are also generated when using metalworking fluids.

The WSO mist collector is not designed to handle water mist alone. There should be some type of oil content to allow coalescing since water vapor will simply pass through the filters. The extremes of very heavy oil and light, thin oil should be avoided. Very heavy oil, similar to tar consistency, will not drain while very light, thin oil, similar to paint thinner consistency, may evaporate.



CAUTION!

- Misuse or modification of this equipment may result in personal injury.
- Do not misuse or modify.

Operation

During normal operation, contaminated air enters the unit through the dirty-air inlet on the bottom of the unit. The incoming air slows, causing large mist droplets and particles to fall out of the air stream. The air passes through a reusable first-stage filter designed to collect and coalesce large droplets and particles.

The primary stage of filtration is the pleated filter cartridge specifically designed to collect, coalesce, and drain fine mist. As the mist coalesces, the droplets are big enough to run down the cartridge and drain back into the collector. The droplets will drain on both the inside and outside of the cartridge. Liquid that collects on the inside of the cartridge drains through the bottom portion of the porous media and into the hopper. Clean, mist-free air exits the cartridge and discharges through the top of the collector.

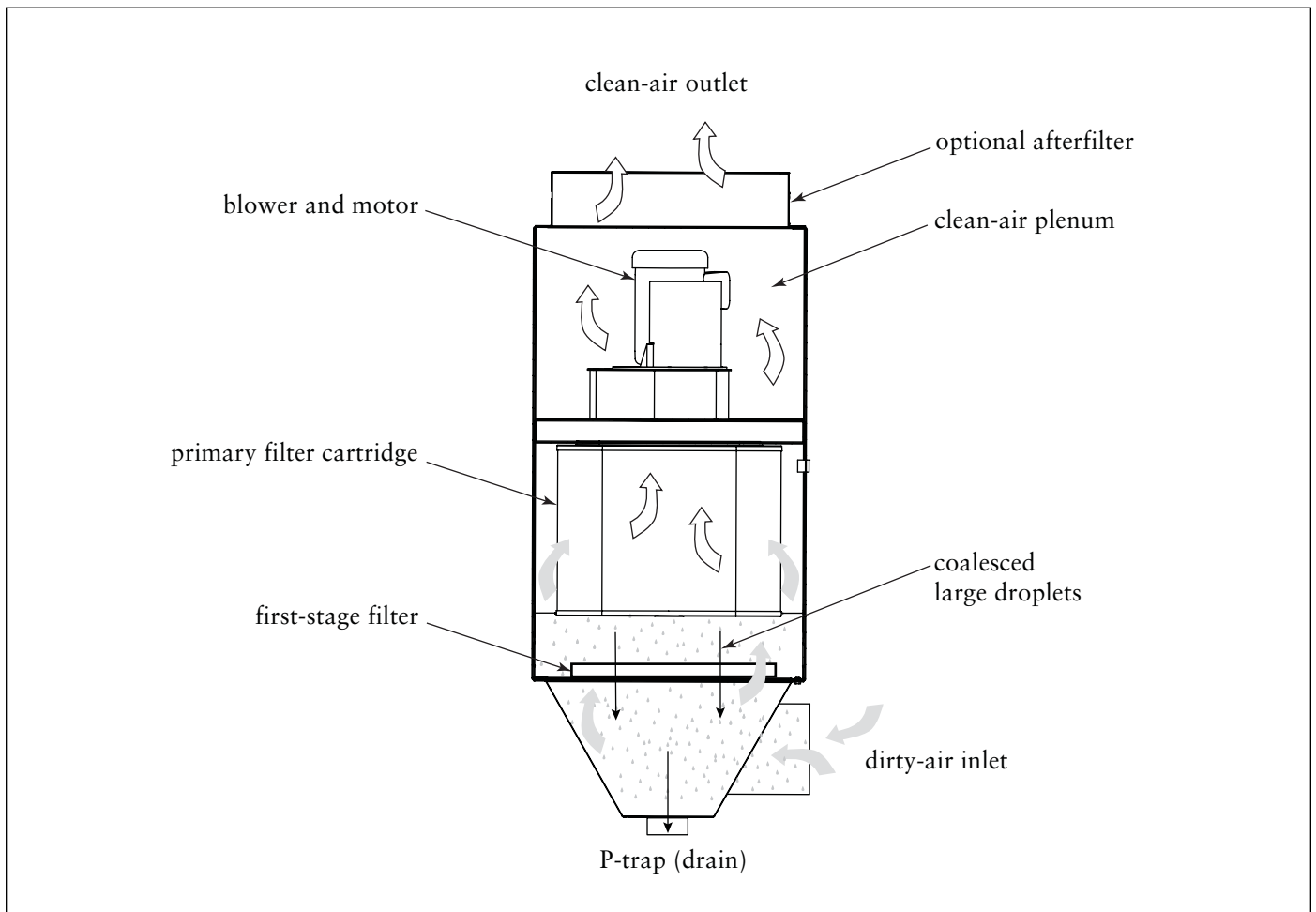

Unit Operation, WSO 15 shown

Inspection on Arrival

1. Inspect unit on delivery.
2. Report any damage to the delivery carrier.
3. Request a written inspection report from the Claims Inspector to substantiate claim.
4. File claims with the delivery carrier.
5. Compare unit received with description of product ordered.
6. Report incomplete shipments to the delivery carrier and your Donaldson representative.
7. Remove crates and shipping straps. Remove loose components and accessory packages before lifting unit from truck.

Installation Codes and Procedures



CAUTION!

OSHA may have requirements regarding recirculating filtered air in your facility. Consult with the appropriate local authorities to ensure compliance with all codes regarding recirculating filtered air.



CAUTION!

Ensure weight of oil-laden unit plus weight of required materials and equipment will be adequately supported. Failure to comply may result in personal injury and/or property damage.

1. Safe and efficient operation of the unit depends on proper installation.
2. Authorities with jurisdiction should be consulted before installing to verify local codes and installation procedures. In the absence of such codes, install unit according to the National Electric Code, NFPA No. 70-latest edition.
3. A qualified installation and service agent must complete installation and service of this equipment.
4. All shipping materials, including shipping covers, must be removed from the unit prior to, or during unit installation.

Note: Failure to remove shipping materials from the unit will compromise unit performance.

Installation

Site Selection, Grade-Mounted Units

1. The unit can be located on a reinforced concrete foundation.
2. Provide clearance from heat sources and interference with utilities when selecting the location.
3. Prepare the foundation in the selected location. Install anchor bolts to extend a minimum of 1 1/2-inches above foundation unless otherwise indicated on the Specification Control drawing.
4. Locate the collector to ensure the shortest and straightest inlet- and outlet-duct length, easy access to electrical connections, and routine maintenance.

Unit Location

Site Selection, Ceiling-Mounted Units:

1. The unit can be suspended or hung from overhead supports. The supports must be adequate to carry the live load of the unit and installation performed to reduce sway or vibration to the unit. The dry unit weight is shown on the specification control drawing shipped with the unit.
2. The live load will include the weight of all ancillary hardware attached to the mist collector, as well as the weight of the mist-laden, wet filters. Consult the coolant MSDS for the specific gravity of the coolant to estimate the weight of the mist-laden, wet filters.
3. Provide clearance from heat sources and interference with utilities when selecting the location for suspended units.

1. When hazardous conditions or materials are present, consult with local authorities for the proper location of the collector.
2. Foundation or overhead support must be sized to accommodate the entire weight of the unit, plus the weight of the collected material, piping, and ductwork.



CAUTION!

Ensure weight of oil-laden unit plus weight of required materials and equipment will be adequately supported. Failure to comply may result in personal injury and/or property damage.



CAUTION!

Donaldson equipment is not designed to support site-installed ducts, interconnecting piping, or electrical services. All ducts, piping, or electrical services supplied by others must be adequately supported to prevent severe personal injury and/or property damage.



CAUTION!

Ensure weight of oil-laden unit plus weight of required materials and equipment will be adequately supported. Failure to comply may result in personal injury and/or property damage.



CAUTION!

- Combustible materials such as buffing lint, paper, wood, aluminum or steel dust, weld fume, or flammable solvents represent fire or explosion hazards.
- Use special care when selecting and operating all collection equipment when combustible materials are present to protect workers and property from damage due to fire and/or explosion.
- Consult and comply with all national and local codes relating to fire or explosion, and all other appropriate codes when determining the location and operation of mist collection equipment.
- Donaldson equipment is not equipped with fire extinguishing or explosion protection systems.

Electrical Wiring



CAUTION!

- Electrical installation must be performed by a qualified electrician and comply with all applicable national and local codes.
- Lock out electrical power sources before performing service or maintenance work.
- Do not install in classified hazardous atmospheres without an enclosure rated for the application.

The only component requiring electrical power is the blower motor.

1. All electrical wiring and connections, including electrical grounding, should be made in accordance with the National Electric Code, NFPA No. 70-latest edition.
2. Check local ordinances for additional requirements that apply.
3. The appropriate wiring schematic and electrical rating must be used. See unit's rating plate for required voltage.
4. An electric disconnect switch having adequate amp capacity should be installed in accordance with Part IX, Article 430 of the National Electrical Code, NFPA No. 70-latest edition. Check unit's rating plate for voltage and amperage ratings.
5. Refer to the wiring diagram for the number of wires required for main power wiring and remote wiring.

Rigging Instructions

Suggested Tools & Equipment

Crane or Forklift	Pipe Wrenches
Slings, Spreader Bars, and Clevis Pins	Socket Wrenches
Drift Pins	End Wrenches
Clamps	Large Crescent Wrench
Screwdrivers	Drill and Drill Bits
	Pipe Sealant

Hoisting Information

1. Use all lifting points provided.
2. Use clevis connectors, not hooks, on lifting slings.
3. Use spreader bars to prevent damage to units' casing. Refer to the Spreader Bar Lifting Detail in the WSO 20 Floor Mount Stand Installation Section.
4. Check the Specification Control drawing for weight and dimensions of the unit, subassemblies, and components to ensure adequate crane capacity.
5. Allow only qualified crane operators to lift the equipment.
6. Refer to applicable OSHA regulations and local codes when using cranes, forklifts, and other lifting equipment.
7. Lift unit and accessories separately, and assemble after unit is in place.



CAUTION!

- Failure to lift the collector correctly can result in severe personal injury and/or property damage.
- Use appropriate lifting equipment and adopt all safety precautions needed for moving and handling the equipment.
- A crane or forklift is recommended for unloading, assembly, and installation of the collector.
- Location must be clear of all obstructions, such as utility lines or roof overhang.

This Page Intentionally Left Blank

Standard Equipment

General Installation

1. Apply a generous amount of sealant when installing attachments.
2. Position the collector above the mist-capture zone. See Collector Positioning.
3. Do not allow a fluid trap to form when using flexible duct. See Flex-Duct Positioning.
4. On enclosed-machine installations, mount the unit as far from the mist throw zone as possible and away from the primary access door to maximize filter life and provide effective mist containment. See Enclosed-Machine Installation illustration.
5. On open-machine installations, position the unit's pick-up hood a minimum of 12-in from the mist source. Avoid mounting the pick-up hood too close to the mist source of an open machine such as a wet surface grinder. Installing too close can shorten filter life as the unit will collect large droplets and particulate instead of mist. See Open Machine Installation.

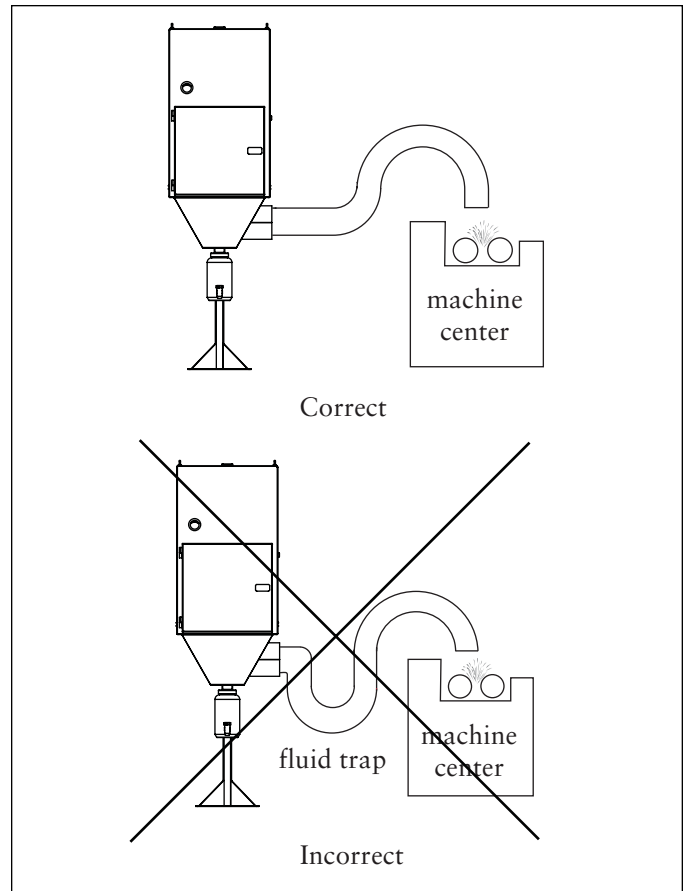

Flex-Duct Positioning, WSO 15 shown

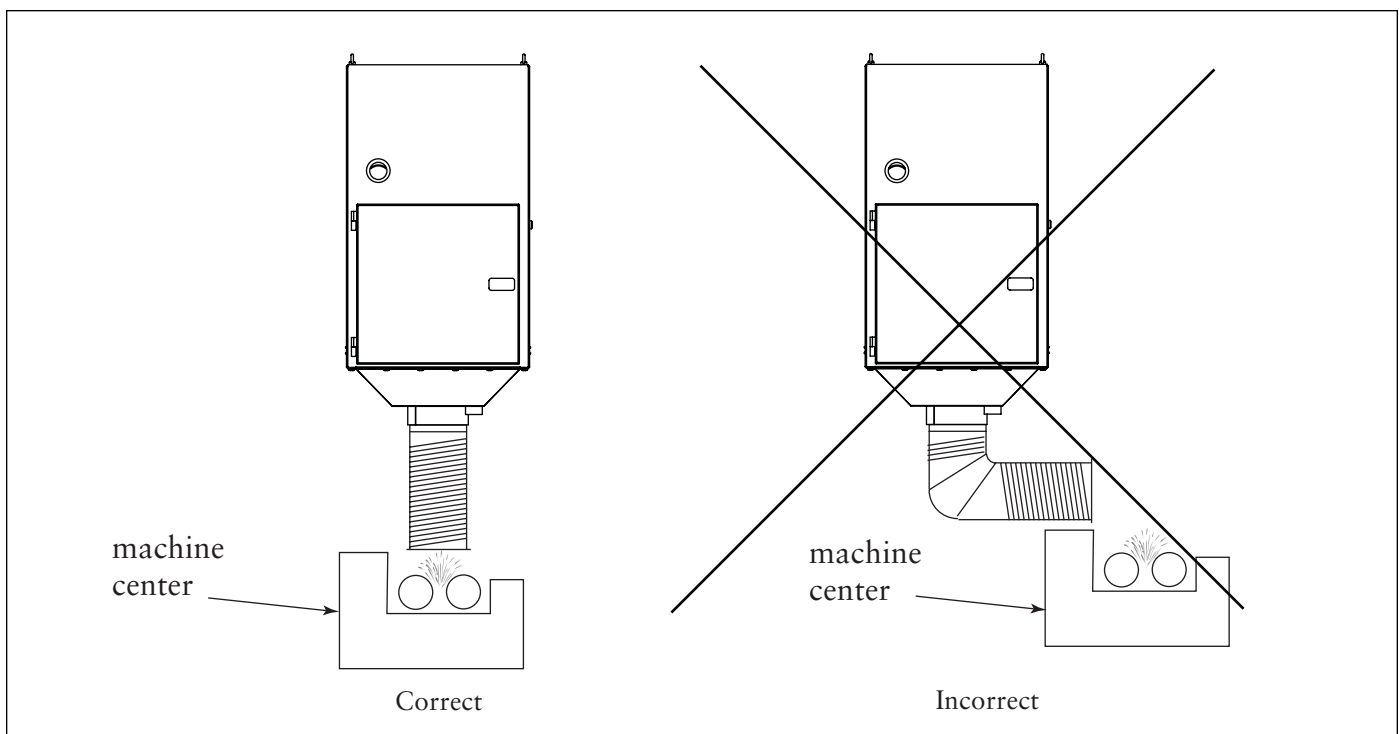

Collector Positioning, WSO 15 shown

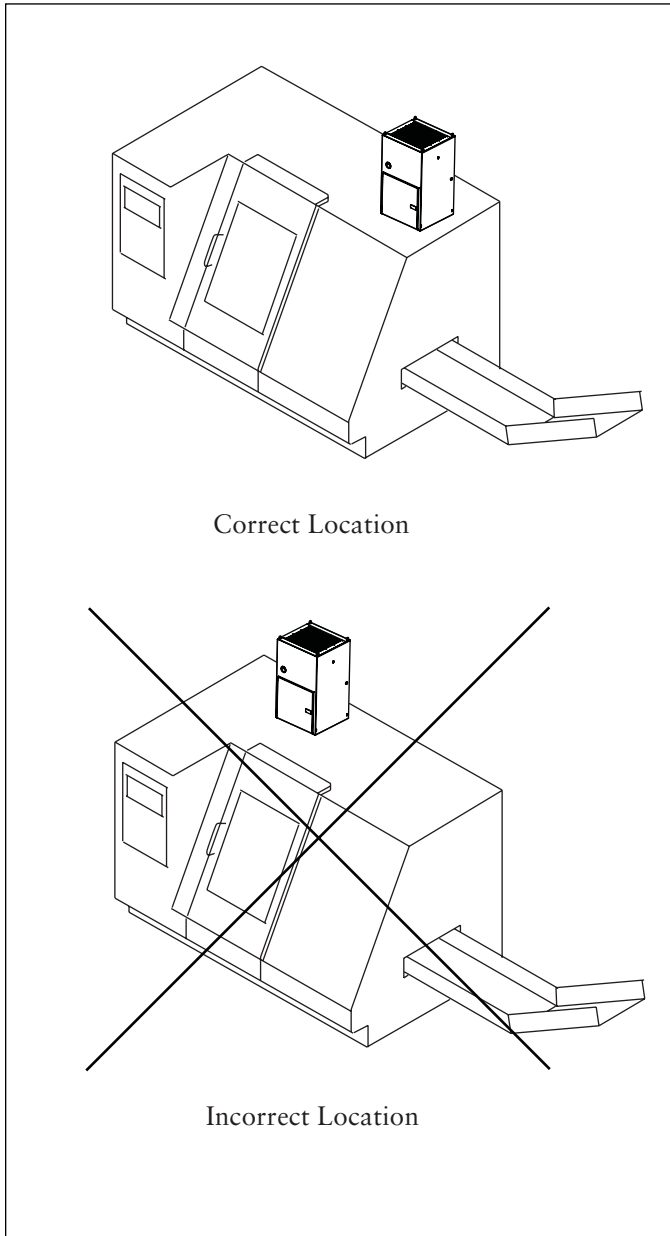

Enclosed Machine Installation, WSO 15 shown

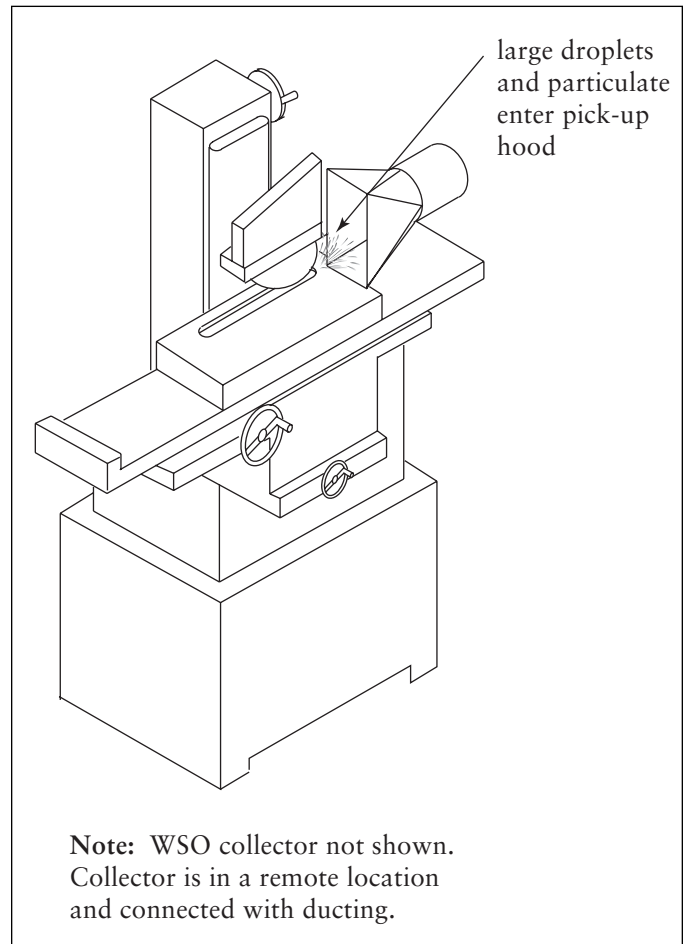

Open Machine Installation

Flush Mount Installation

The flush mount option is for installing a collector on a machine center that has a large flat unobstructed top surface.

1. Open the units access door and remove the primary and first stage filters.
2. Remove the filter retention system.
3. Layout and drill bolt hole pattern into the top of machine center (refer to Specification Control drawing for bolt size and pattern).

Note: Alternative option is to trace bolt hole pattern directly onto machine center.

4. Cut opening into machine center and drill mounting holes.
5. Apply generous amounts of sealant to the outside perimeter of the bolt pattern on the machine center.
6. Carefully lift unit into position over the machine center and lower into position.
7. Install and tighten fasteners into every hole.
8. Install filter retention system and filters.

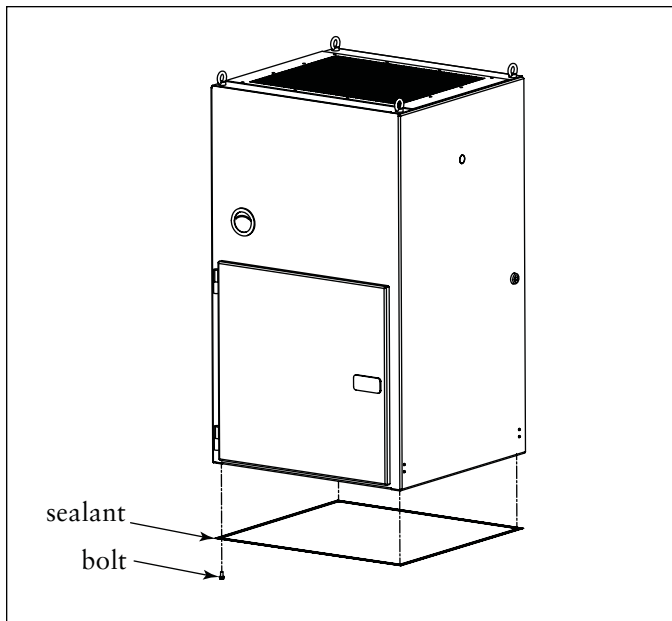

Flush Mount Installation, WSO 15 shown

Flanged Inlet Hopper Installation

This flanged inlet hopper option is for installing a collector on a machine center that has a limited amount of unobstructed top surface.

1. Open the units access door and remove the primary and first stage filters.
2. Remove the filter retention system.
3. Carefully lift unit into position over the machine center and lower into position.
4. Trace bolt pattern onto the machine center or match drill pattern.
5. Cut opening into machine center and drill mounting holes.
6. Move the unit aside and apply generous amounts of sealant to the outside perimeter of the bolt pattern on the machine center.
7. Carefully position unit over the bolt pattern and lower into position.
8. Install and tighten fasteners into every hole.
9. Install filter retention system and filters.

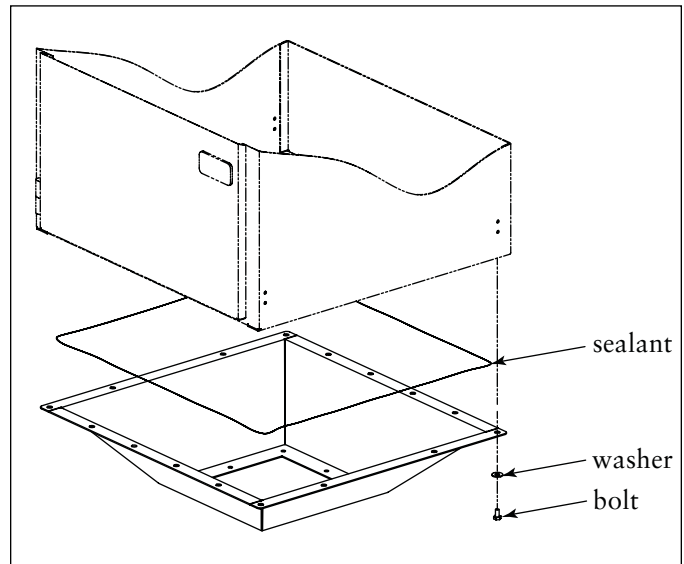

Flanged Inlet Hopper Installation, WSO 15 shown

Ceiling Mount Installation

1. Verify that the ceiling attachment points can bear the live load.
2. Use properly sized cable or chain to attach to each of the four eyebolts to suspend the unit from the ceiling.
3. To prevent sway, position the chain or cable to form a 60 degree angle to the top of the unit and a 45 degree angle along the sides.



CAUTION!

Ensure weight of oil-laden unit plus weight of required materials and equipment will be adequately supported. Failure to comply may result in personal injury and/or property damage.



CAUTION!

- Failure to lift the collector correctly can result in severe personal injury and/or property damage.
- Use appropriate lifting equipment and adopt all safety precautions needed for moving and handling the equipment.
- A crane or forklift is recommended for unloading, assembly, and installation of the collector.
- Location must be clear of all obstructions, such as utility lines or roof overhang.

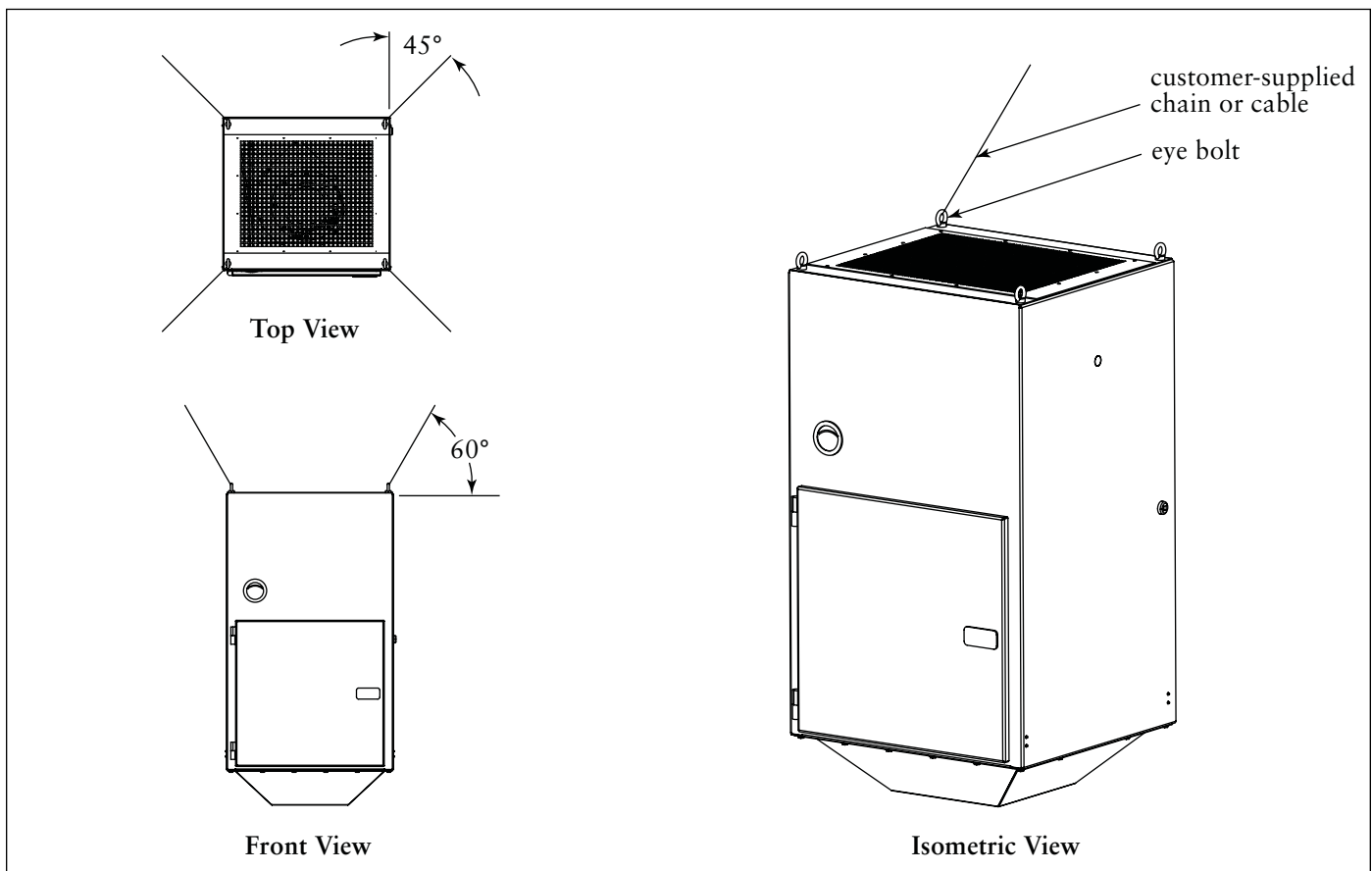

Ceiling Mount Installation, WSO 15 shown

Machine Center Mount with Vertical inlet Hopper and Vibration Isolators Installation

Vertical inlet hopper and vibration isolators are for installing a collector on a machine center that is sensitive to vibration.

1. Carefully lift unit into position over the machine center and lower into position.
2. Trace bolt hole pattern for vibration isolators on the base of legs to the machine.
3. Drill four 1/2-in holes into the machine center for installing the vibration isolators.
4. Fasten the isolators to machine center.
5. Carefully position unit over the isolators and lower into position.
6. Install and tighten fasteners. Vibration isolator needs to be torqued to 12.0 ft-lbs.
7. Connect the flexible duct using the hose clamps to the collector and the machine center collar. See Inlet Hopper with Flex-Duct Installation section.

Note: If machine center has no inlet collar, order part from Donaldson Parts Express Line (1-800-365-1331).

8. Install P-trap or 1 1/2-in NPT plug. If a plug is used, a shallow pool of coolant will be present at the bottom of the hopper before it drains down the inlet duct.

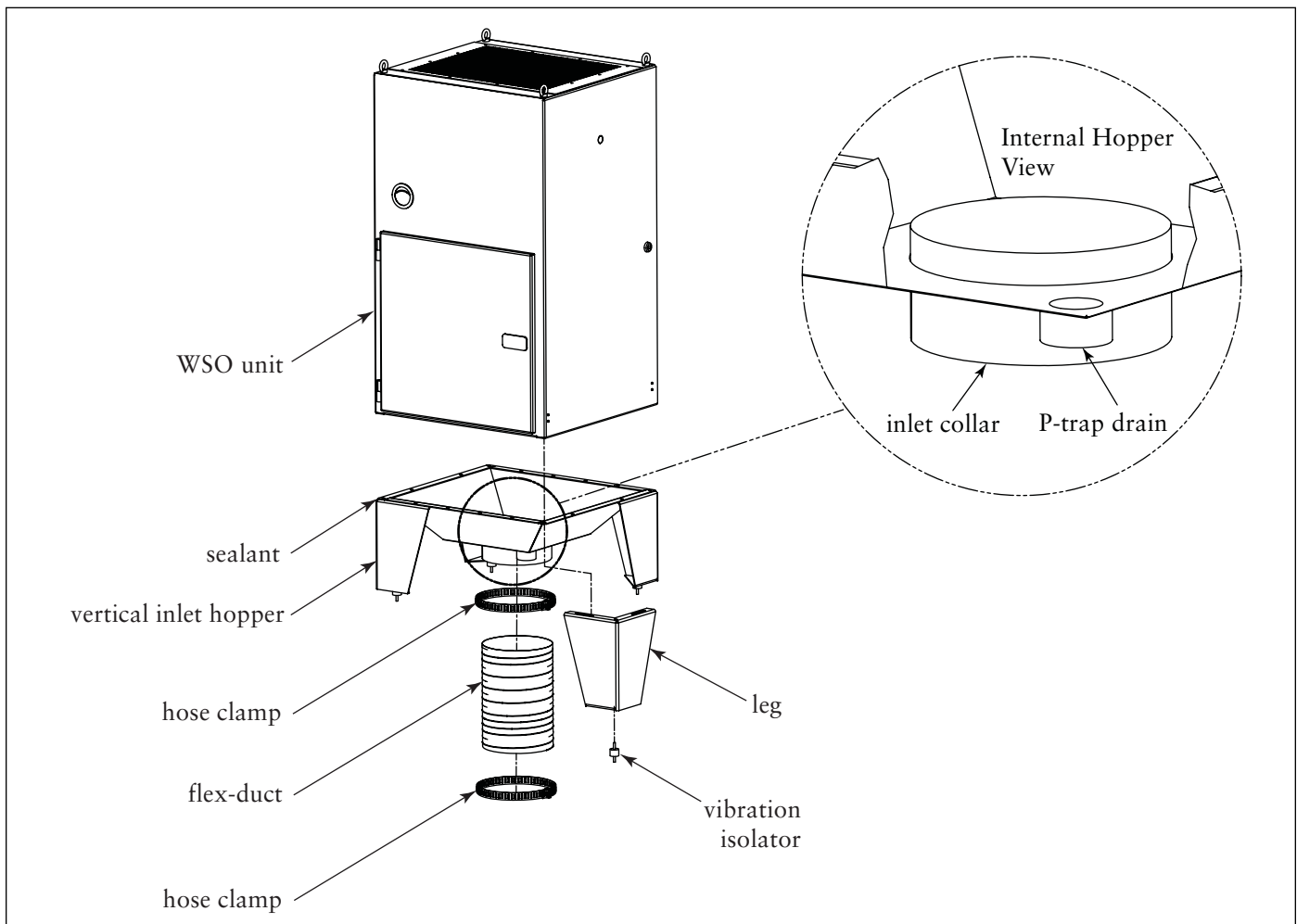

Inlet Hopper with Vibration Isolators Installation, WSO 15 shown

This Page Intentionally Left Blank

WSO 10, 15 Collector Stand Installation

For applications with limited mounting surfaces, an adjustable stand is available for the WSO 10 and 15. The stand height may be adjusted up to a maximum of 117-in from the top of the collector to the bottom of the stand.



CAUTION!

If collector drainage is not properly maintained, the collector may collapse on stand and cause severe personal injury and/or property damage. Maintain proper collector drainage.



CAUTION!

Donaldson equipment is not designed to support site-installed ducts, interconnecting piping, or electrical services. All ducts, piping, or electrical services supplied by others must be adequately supported to prevent severe personal injury and/or property damage.

1. Install customer-supplied anchor bolts (Hilti Kwik Bolt 3 [KB3] 3/8-in diameter x 1.63-in embedment in uncracked 2,500 psi concrete or equivalent) in the floor extending 1 1/2 inches above surface. Use anchor bolt pattern from the stand specification drawing or see anchor bolt pattern on stand base.
2. Install stand base, level, and securely tighten anchor bolts. See Stand Base Installation below.
3. Orient the front of the mist collector to face the forklift. Adjust the forks of the forklift to lift collector on the cabinet and inlet flange. Secure unit to the forklift. See Collector on Forklift detail.
4. Remove the center two inlet hopper bolts from the back of the unit and install the formed angle stabilizing bracket using the bolts and washers removed from the inlet hopper. See Detail A.
5. Remove the two eyebolts on the back of the collector and attach the upper stand bracket of the stand to the collector using the provided 8mm bolts and washers. See Detail B.
6. Using the provided hardware 3 1/4-in x 3/8-in bolts and mounting plate, secure the bottom of the collector to the stand. See Detail A.
7. Securely fasten all hardware. See Details A and B.
8. Lift collector and top portion of the stand over previously installed stand base and lower to the desired height. See Upper and Lower Stand Installation detail and Stand Height Adjustment detail.
9. Securely fasten the clamping hardware for added safety. See Detail D.
10. Permanently secure the stand height by drilling a 3/8-in hole through the upper and lower tubes and securing with a 1/2-in nut and bolt. See Detail C.

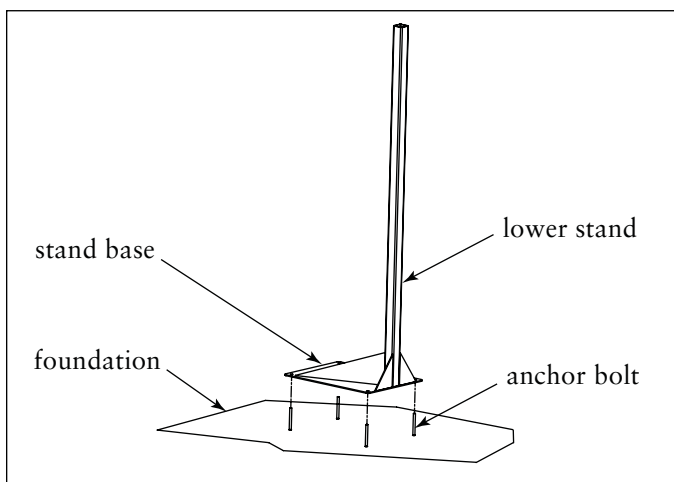

Stand Base Installation, WSO 15 shown

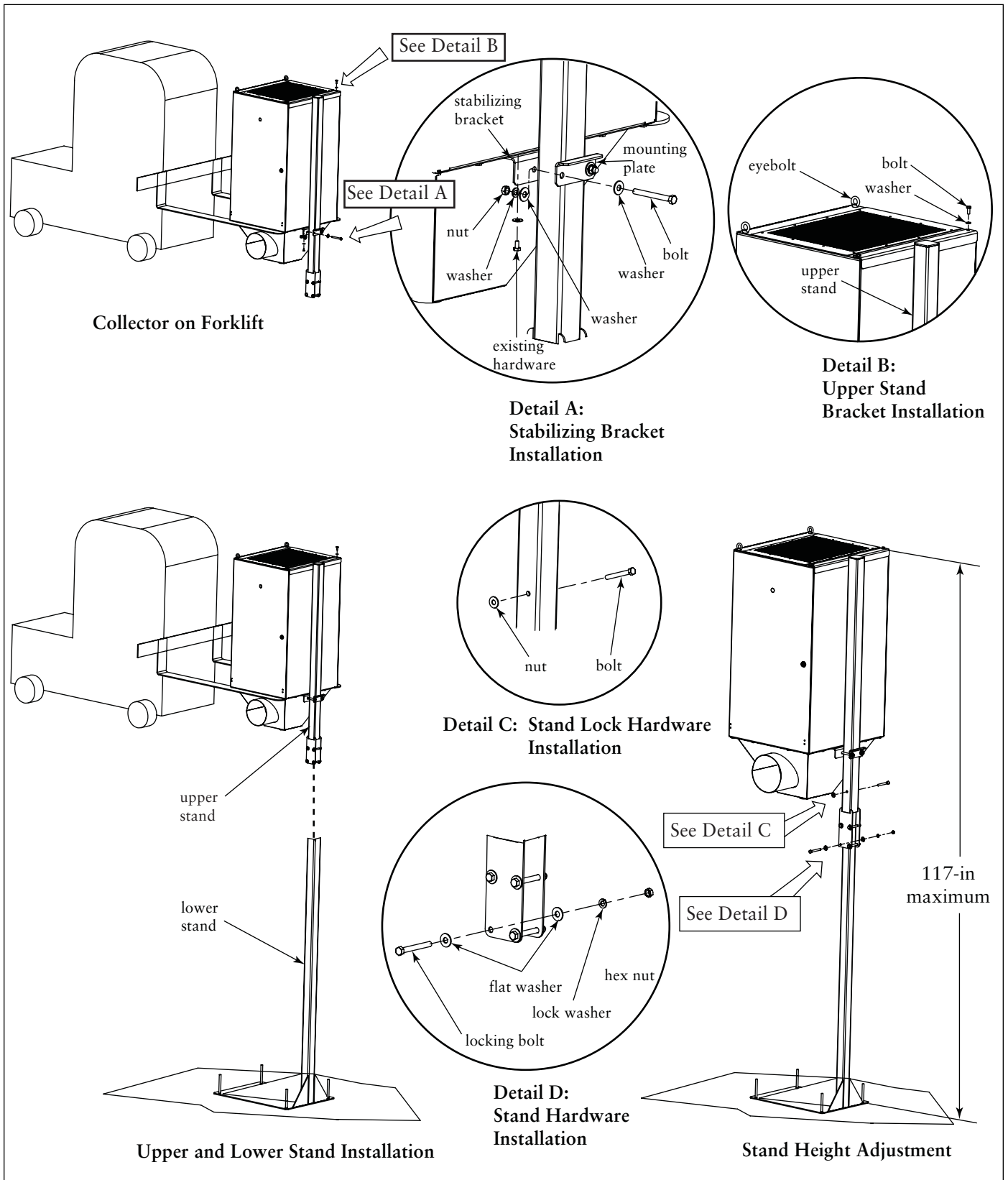

Collector Stand Installation, WSO 15 shown

WSO 20 Floor Mount Stand Installation



CAUTION!

The collector has a high center-of-gravity and may overturn if not secured properly.

- Secure the collector to the lifting device.
- Use care when moving the unit.

1. Prepare the foundation in the selected location. Install customer-supplied anchor bolts to extend a minimum of 1 1/2-in above foundation. Anchor bolt pattern and recommended anchor bolt specifications are shown on the specification control drawing.

2. Using a crane or forklift, raise the WSO 20 collector and lower into position onto anchor bolts. Level unit and secure all hardware.

Note: When using a crane, use clevis pins and a sling attached to four eyebolts.



CAUTION!

The collector has a high center-of-gravity and may overturn if not secured properly. Secure the collector properly.

3. Remove crane or forklift.

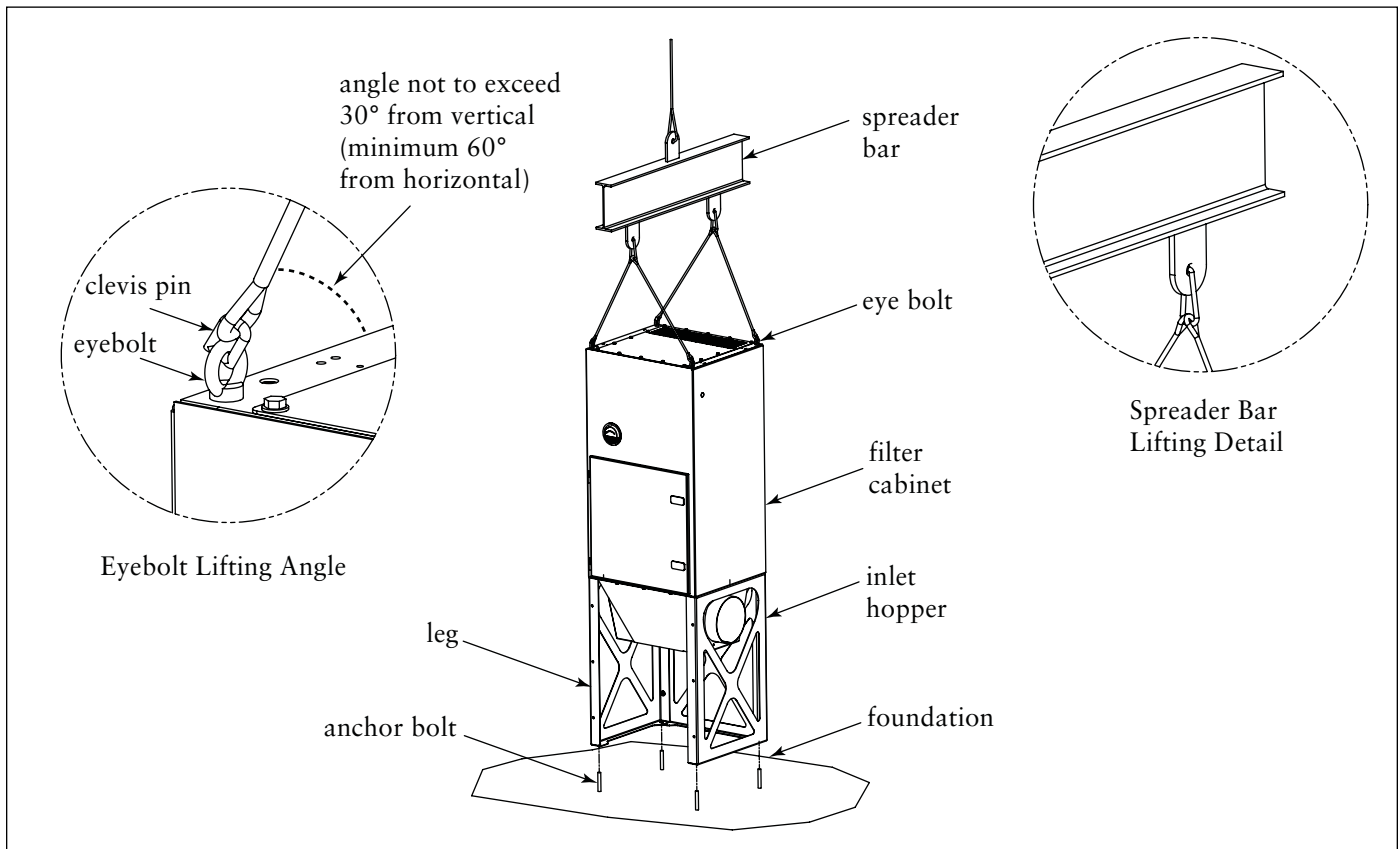

Floor Mount Stand Installation, WSO 20 shown

Inlet Hopper with Flex-Duct Installation

This option is available for ceiling mounted units or units on stands. Included components are a 6-in integrated collar on the inlet hopper, 10-ft flexible duct, and two 6-in hose clamps.

1. Slip flex-duct over inlet collar on collector and install hose clamp over flex-hose and collar and securely fasten.
2. Trim flex-duct to the desired length and fasten to machine center or inlet hood with remaining hose clamp.

Note: Do not allow flexible duct to create a fluid trap. See Flex-Duct Positioning illustration in General Installation section.

3. Install drain / P-trap. See P-Trap Installation section.

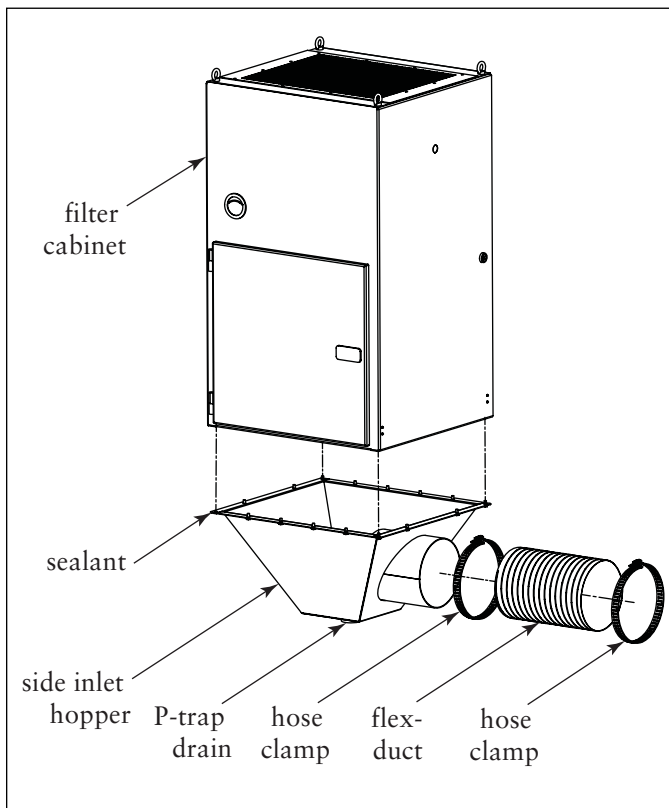

Side Inlet Hopper with Flex-Duct, WSO 15 shown

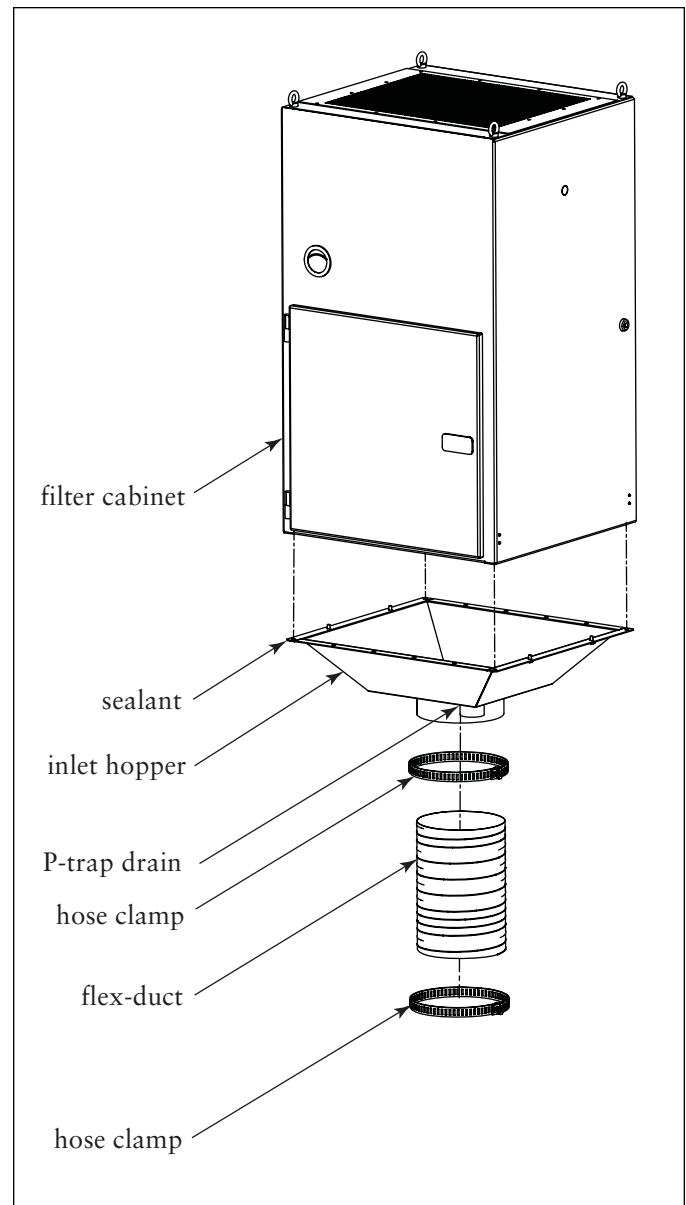

Inlet Hopper with Flex-Duct, WSO 15 shown

P-Trap Installation

Note: Ensure P-trap is designed with sufficient fluid head to overcome blower static capabilities. An incorrectly sized P-trap will result in coolant pooling within the inlet plenum.

1. Install the P-trap as shown in P-Trap Installation.
2. Position the P-trap outlet to the proper location and tighten the union.
3. Plumb the P-trap to a receptacle or install a return line back to the machine center.
4. Fill P-trap before starting unit.

Note: The characteristics of some machining fluids change with time, use, and exposure to air. Check the condition of the collected fluid before re-using.

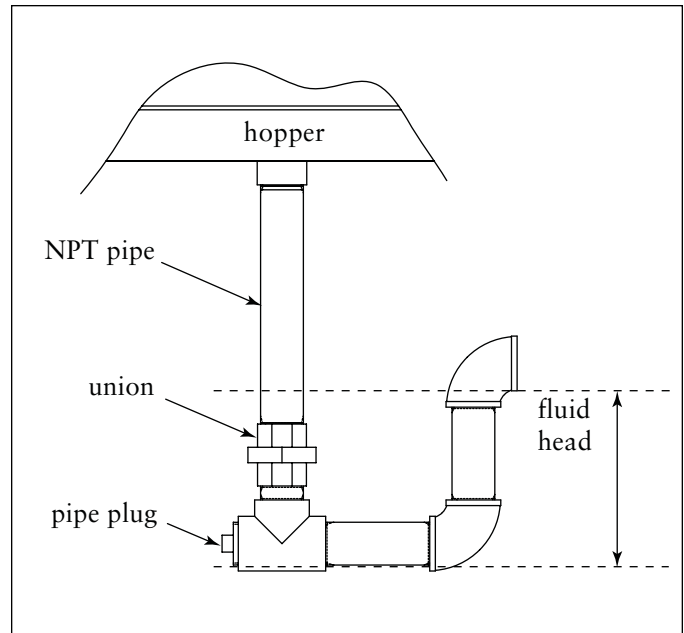

P-Trap Installation



CAUTION!

Ensure collected material properly flows through the P-trap. Improperly operating P-trap may result in property damage.

Electrical Connection



CAUTION!

- Electrical installation must be performed by a qualified electrician and comply with all applicable national and local codes.
- Lock out electrical power sources before performing service or maintenance work.
- Do not install in classified hazardous atmospheres without an enclosure rated for the application.

WSO mist collectors must be equipped with a customer-supplied safety disconnect with short circuit protection, contactors, and overload protection. Complete the wiring as shown in Motor Starter Wiring.

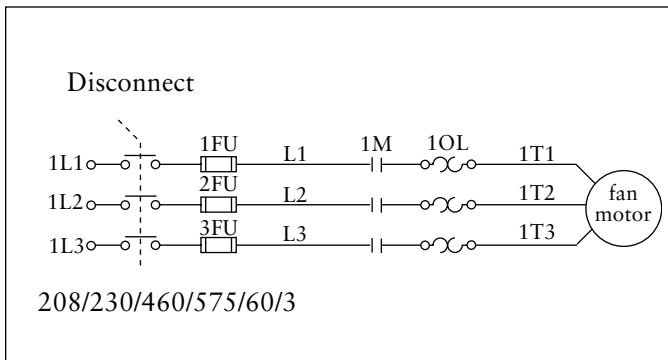

Motor Starter Wiring

Motor Starter Control Box

Mount the motor starter control box in a convenient location. An electrical knockout, sized for 1/2-in fittings, is provided on the left-hand side of the blower cabinet. Increase knockout size using a drill as required.

1. Using the wiring diagram supplied inside the control box and the instructions on the motor decal, make the connections to the blower motor.

Note: If the unit is supplied with an optional junction box, wire the motor starter to the terminal strip located inside the junction box according to the wiring diagram supplied with the junction box.

2. Turn the blower motor ON then OFF and check for proper rotation. See rotation arrow on the motor's mounting plate.

To reverse rotation, three-phase power supply:

Turn electrical power OFF at source, properly lock-out power, and switch any two leads on the output-side of the blower motor starter.

3. Ground cabinet according to local electric codes.



CAUTION!

- Do not look into blower outlet to determine rotation.
- Check that the exhaust plenum is free of tools or debris before checking blower rotation.
- Stand clear of exhaust to avoid personal injury.

Optional Equipment

Factory-Installed HEPA/95% DOP Filter

Any HEPA or 95% DOP Filter module ordered with any WSO collector comes with a factory-installed Minihelic gauge for measuring the pressure drop across the filter.

The HEPA or 95% DOP afterfilter is attached to the top of the WSO unit using side-mounted latches.

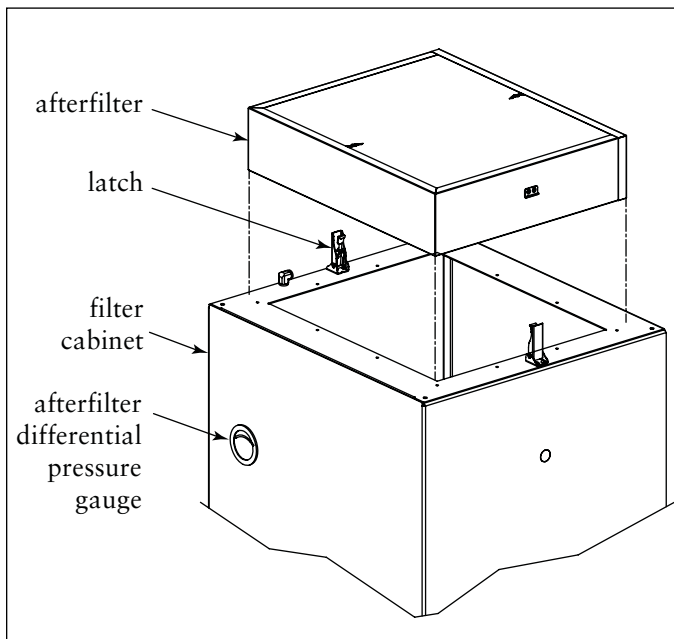

Afterfilter Differential Pressure Gauge with HEPA/95% DOP Module, WSO 15 shown

Retrofit Kit Field Installation

An afterfilter installation retrofit kit is available for customers who decide to add a HEPA or 95% DOP filter to an existing field-operating WSO machine-mountable unit originally configured with a standard exhaust. The field kit includes: afterfilter, latches, hardware, and differential pressure gauge kit.

Latch and Afterfilter Installation

1. Turn the blower motor off and properly lock-out electrical power.
2. Remove the exhaust grill by removing the fasteners. The exhaust grill is not reinstalled.
3. Locate the existing sets of latch holes on the roof.
4. Using the latch hardware provided, install the latches as shown in the Latch Installation sketch.
5. Place the afterfilter, gasket side down, on top of the exhaust outlet, and secure with the latches.

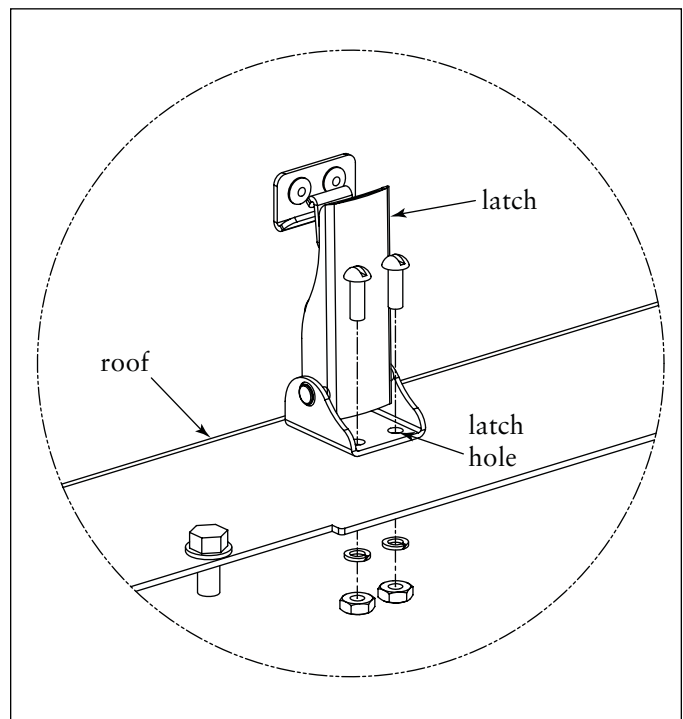

Latch and Afterfilter Installation

Afterfilter Differential Pressure Gauge Installation

The Minihelic gauge is used to measure the pressure drop across the afterfilter.

1. Locate the Minihelic knock-out in cabinet.
2. Remove the knockout from the front of unit.
3. Install the Minihelic gauge per the Minihelic installation sketch.

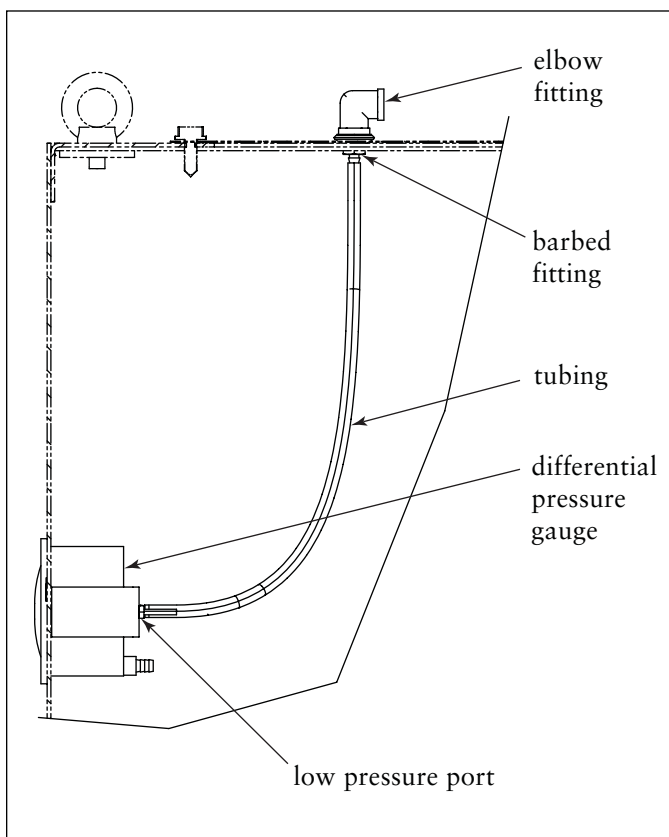

*Afterfilter Differential Pressure Gauge,
WSO 15 shown*

Sprinkler Installation



CAUTION!

Sprinkler systems place a large quantity of water in the mist collector when activated. Provide adequate drainage to remove water. Excess water and ancillary hardware weight can cause the leg structure to collapse.

An optional fire control sprinklers is available for the WSO mist collector. Wuxi opeartion don't provide this as one option .It should be provided by customer who should depend on location authorities.

Note: Consult with local authorities when installing fire control systems on collection equipment.

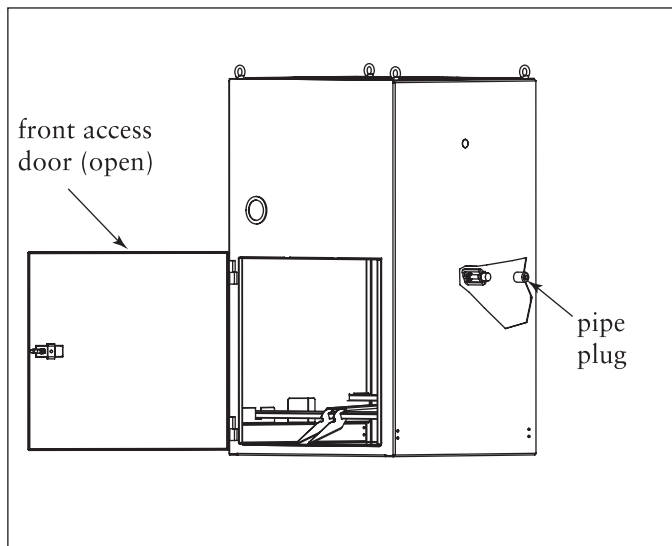

Sprinkler Installation (Blower Cabinet), WSO 15 shown

Drain Collection Container

The optional drain collection container is intended for use where small amounts of liquid are collected and requires regularly scheduled maintenance. Failure to empty the collection bottle will result in inlet plenum overflow.

1. Install the drain collection container during installation or after unit is in its' final operating position.
2. Turn unit OFF.
3. Remove the container by unscrewing the container from the cap. Clean the container, faucet, and re-install.

Note: Close the faucet before turning the collector back ON.

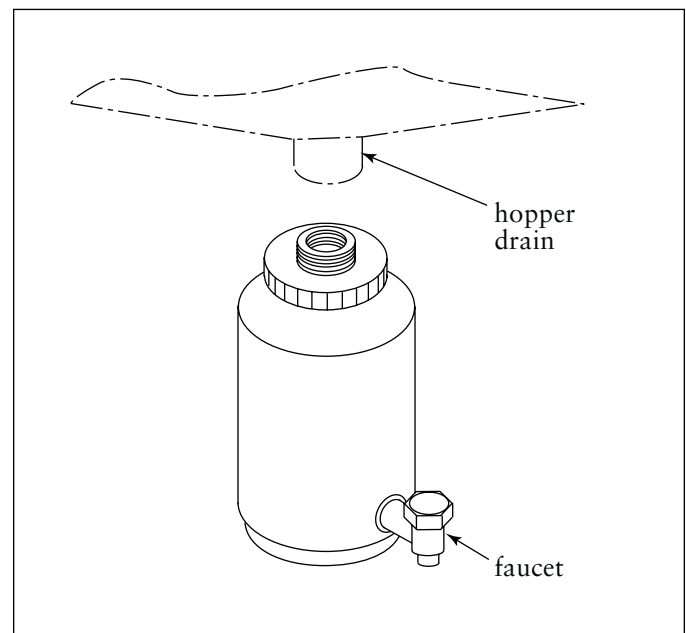

Drain Collection Container

Preliminary Start-Up Check



CAUTION!

Lock out electrical power sources before performing service or maintenance work.

1. Check all electrical connections for tightness and contact.
2. Check for and remove all loose items in or near the inlet and outlet of the unit.
3. Check that all remote controls are wired into the control system, and all service switches are in the OFF position.
4. Check that all optional accessories are installed properly and secured.
5. Check that all filters are properly installed and filter access doors are closed and latched.
6. Check that hopper discharge is open and the storage container is sealed, if equipped.
7. Fill P-trap if equipped, or close faucet valve on drain collection container if used.
8. Turn power ON at source.
9. Turn the blower motor ON then OFF to check for proper rotation by referencing the rotation arrow located on the motor's mounting plate.



CAUTION!

- Do not look into blower outlet to determine rotation.
- Check that the exhaust plenum is free of tools or debris before checking blower rotation.
- Stand clear of exhaust to avoid personal injury.
- Do not operate without proper Donaldson filters.

To reverse rotation, three-phase power supply:

Turn electrical power OFF at source, properly lock-out power, and switch any two leads on the output-side of the blower motor starter.

10. Adjust the blower for proper airflow by adjusting the volume control damper on the blower discharge, if equipped.

Note: Excess airflow can shorten filter life, cause electrical system failure, and blower motor failure.

Service Information



CAUTION!

Lock out electrical power sources before performing service or maintenance work.

Operational Checklist

1. Monitor overall performance of the collector.
2. Monitor exhaust. Exhaust should remain visually clean throughout filter life. If leaks are visible, check the filters for positive gasket seals.
3. Monitor hopper drainage. If slow or stopped, check hopper for obstructions and clean as necessary.
4. Check that the P-trap is full. Refill if low or dry.
5. Monitor pressure drop across the primary filter and afterfilter (if equipped) using the appropriate differential pressure gauge. See Filter Cleaning and Replacement section.
6. For a typical installation, Donaldson recommends filter replacement when the gauge indicator needle is half way into the red zone. See Filter Cleaning and Replacement section.

Note: Do not attempt to clean or wash the primary filter. Replace only.

Note: Do not operate the unit without the first-stage or primary filter in place. Significant reduction in final filter life can result.

This Page Intentionally Left Blank

First Stage Filter Cleaning and Replacement

Remove the first stage filter through the lower access door. Clean the first-stage screen by tapping it gently over an appropriate waste container. If further cleaning is required, wash in an appropriate wash tank. To clean the first-stage filter, soak in an appropriate wash tank, rinse, dry, and re-install.

Note: High temperature, steam-cleaning methods should not be used with the polypropylene filters due to the temperature limitations.

Do not operate the WSO mist collector without the first-stage filter in place. Significant reduction in primary filter life can result.



CAUTION!

- Use proper safety and protective equipment when removing contaminants and filters.
- Dirty filters may be heavier than they appear.
- Use care when removing filters to avoid personal injury.
- Do not drop filters.

Primary Filter Replacement

Note: With the unit's airflow off, allow mist-laden, wet filter to drain into the inlet plenum for at least 15 minutes prior to removal.

1. Remove the filter cartridge by pulling the filter retention lever down to a horizontal position. Remove cartridge from unit and dispose of properly for the materials collected.

Note: A large plastic garbage bag placed over the top of the used filter allows cleaner filter change out. The filter can be tipped forward and out of the unit while the bag is pulled up over the bottom of the cartridge.

2. Place new filter on the filter retention platform, gasket side up. Slide filter back as far as it will go.

Note: The primary filter must be replaced. Do not wash.

3. Lift the filter retention lever up and close access door.



CAUTION!

Loaded mist collection filters can exceed 40 lbs. Take appropriate precautions when lifting filters or risk personal injury.



CAUTION!

- Use proper safety and protective equipment when removing contaminants and filters.
- Dirty filters may be heavier than they appear.
- Use care when removing filters to avoid personal injury.
- Do not drop filters.

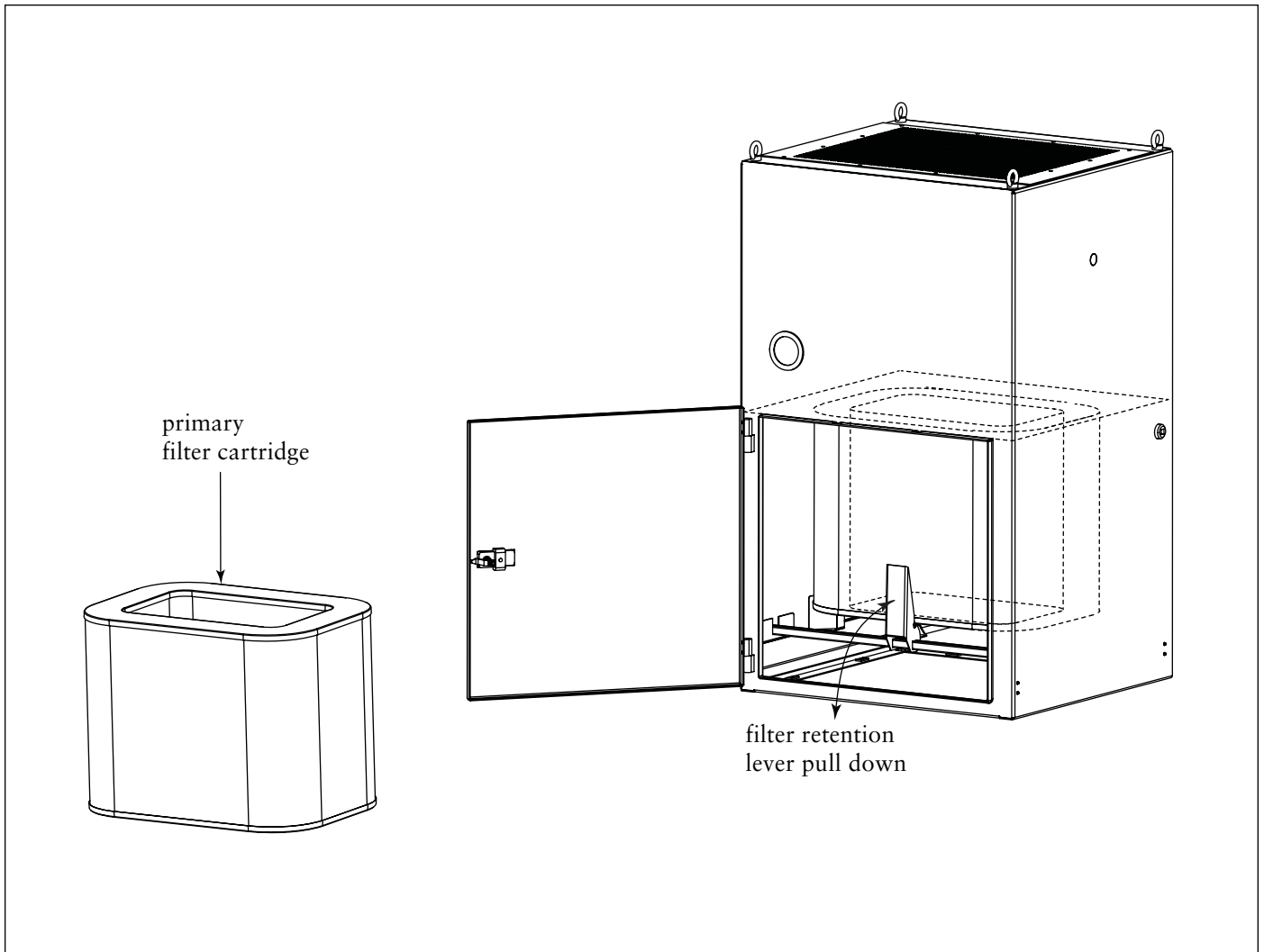

Primary Filter Replacement, WSO 15 shown

Final Filter Replacement

Note: The final filter must be replaced.
Do not wash.

1. Unlatch the final filter on top of the unit.
2. Remove the filter and dispose of properly for the collected materials.

Note: Dirty filters may be heavier than they appear. Provide a support platform or have two people, one on each side of the filter and pull the filter out.

3. Install the replacement filter gasket-side down.
4. Latch the new filter in place.

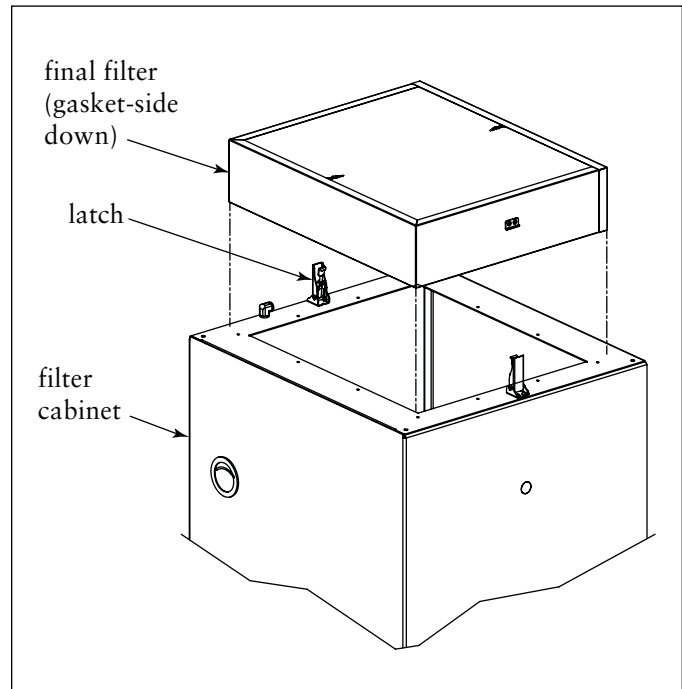

Final Filter Replacement, WSO 15 shown

P-Trap Service

1. Place a suitable container under the P-trap, turn the collector OFF and remove the pipe plug.
2. Allow fluid and particulate to drain.
3. Inspect interior of P-trap and remove any material blockage.
4. Use thread sealant and replace pipe plug.
5. Refill the P-trap with suitable fluid before restarting the collector.

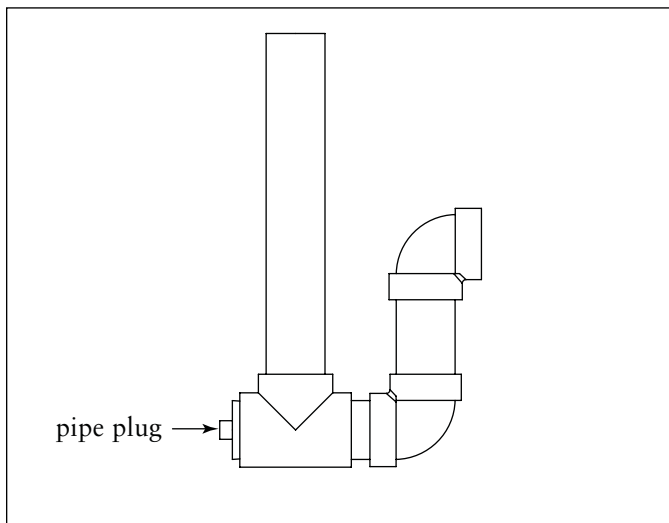

P-Trap

P-Trap with Y-Strainer, Screen Cleaning and Removal

1. Place a suitable container under the screen clean-out valve, turn the collector OFF, close the P-trap valve, then open the screen clean-out valve.
2. Allow fluid and particulate to drain.
3. With the clean-out valve open, slowly open the P-trap valve. This allows fluid still trapped in the hopper to drain.

Note: A substantial amount of fluid may be trapped in the hopper and could exceed the container capacity. Open the P-trap valve slowly.

4. Close the P-trap valve.
5. Unscrew the screen cap and pull the screen out.
6. Clean the screen and the inside of the Y-strainer body and re-assemble taking care to seat the screen in the body and cap.
7. Close the clean-out valve.
8. Open the P-trap valve.
9. Refill the P-trap with suitable fluid before restarting the collector.

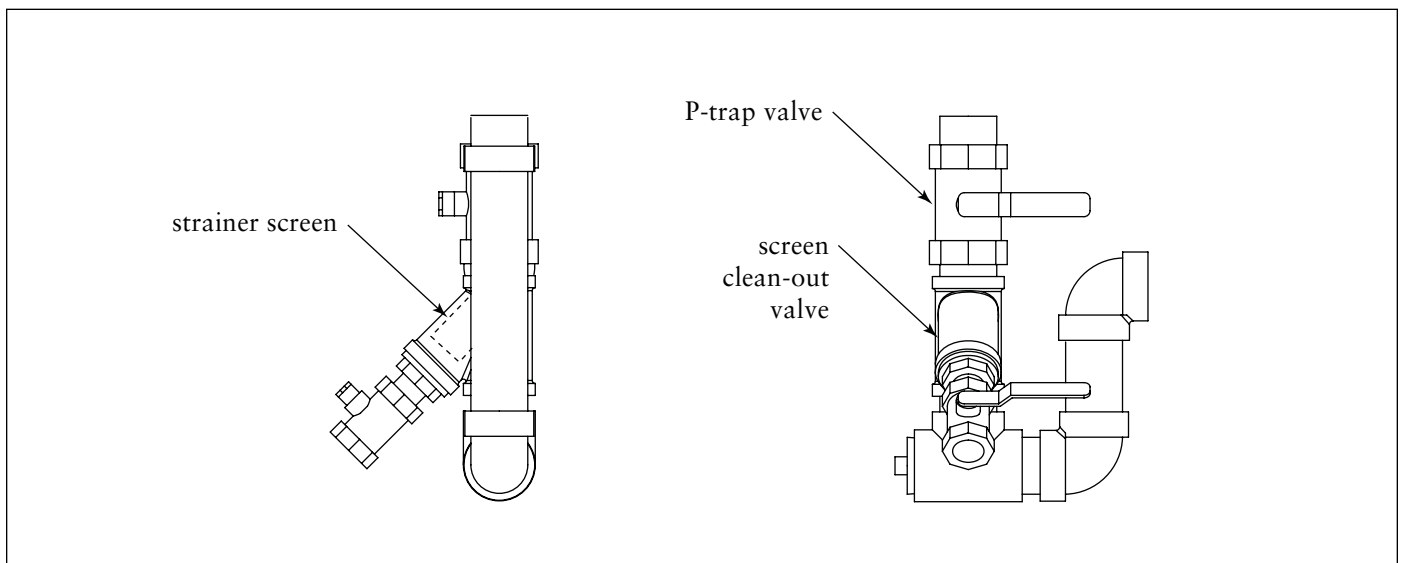

P-Trap with Y-Strainer

Drain Collection Container

Note: Service the drain collection container before it becomes completely filled with fluid. Fluid above the container will discharge when the container is disconnected from the collector.

1. Turn unit OFF.
2. Remove the container by unscrewing the container from the cap. Clean the container, faucet, and reinstall.

Note: Close the faucet before turning the collector back ON.

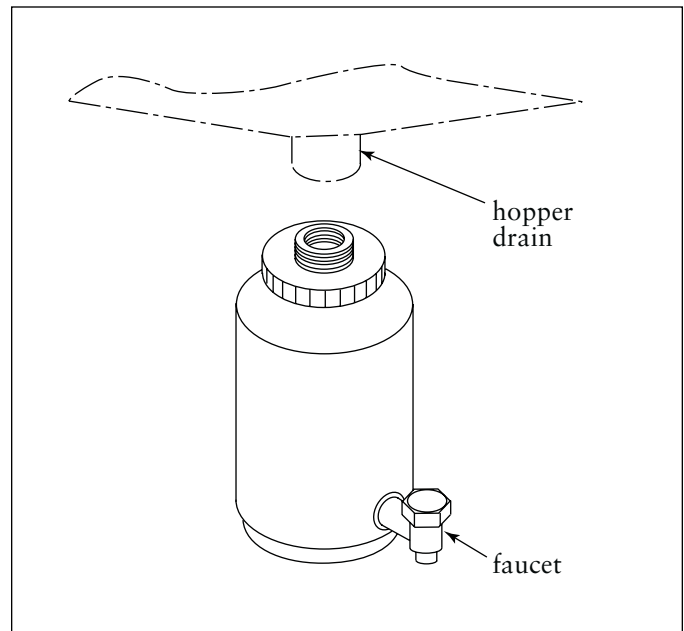

Drain Collection Container

Troubleshooting

Problem	Probable Cause	Remedy
Blower and motor do not start	Improper motor wire size	Rewire using the correct wire gauge as specified by national and local codes.
	Not wired correctly	Check and correct motor wiring for supply voltage. See motor manufacturer's wiring diagram. Follow wiring diagram and the National Electric Code.
	Unit not wired for available voltage	Correct wiring for proper supply voltage.
	Input circuit down	Check power supply to motor circuit on all leads.
	Electrical supply circuit down	Check power supply circuit for proper voltage. Check for fuse or circuit breaker fault. Replace as necessary.
	Overload relay tripped	Reset. Check amp draw on motor leads.
Blower and motor start, but do not stay running	Defective overload heater or overload assembly	Replace as necessary.
	Incorrect motor starter heater elements installed	Check for proper heater elements and replace if necessary.
	Access doors are open or not closed tight	Close and tighten access doors.
Clean-air outlet discharging oil mist	Electrical circuit overload	Check that the power supply circuit has sufficient power to run all equipment.
	Filter cartridges not installed correctly	See Filter Service section.
Inlet discharging volumes of oil	Filter cartridge damage, dents in the end caps, gasket damage or holes in pleated media	Replace filters as necessary. Use only genuine Donaldson replacement parts. See Filter Service section.
	Plugged P-trap	Clean P-trap. See P-Trap Service Section.
	Plugged or full drain collection container	Remove and clean or empty the drain collection container.

Troubleshooting, continued

Problem	Probable Cause	Remedy
Insufficient airflow	Blower rotation backwards	Proper blower rotation is clockwise when looking down at the blower motor. See Preliminary Start-Up Check section.
	Access doors open or not closed tight	Check that all access doors are in place and secured.
	Blower exhaust area restricted	Check blower exhaust area for obstructions. Remove materials or debris.
	First-Stage filter plugged	Remove and clean or replace.
	Primary filter needs replacement	Remove and replace using genuine Donaldson replacement filter. See Primary Filter Replacement section.
	Plugged HEPA filter	Remove and replace. See HEPA Filter Replacement section.
Insufficient hopper discharge	Plugged hopper screen	Remove and clean hopper screen.
	Plugged P-trap	Clean P-trap. See P-Trap Service section.
Liquid leaking from collector door	Plugged P-trap	Clean P-trap. See P-Trap Service section.
	Plugged or full drain collection container	Remove and clean or empty the drain collection container.

This Page Intentionally Left Blank

This Page Intentionally Left Blank

The Donaldson Torit Warranty

Donaldson does not warrant against damages due to corrosion, abrasion, normal wear and tear, product modification, or product misapplication. Donaldson also makes no warranty whatsoever as to any goods manufactured or supplied by others including electric motors, fans and control components. After Donaldson has been given adequate opportunity to remedy any defects in material or workmanship, Donaldson retains the sole option to accept return of the goods, with freight paid by the purchaser, and to refund the purchase price for the goods after confirming the goods are returned undamaged and in usable condition. Such a refund will be in the full extent of Donaldson's liability. Donaldson shall not be liable for any other costs, expenses or damages whether direct, indirect, special, incidental, consequential or otherwise. The terms of this warranty may be modified only by a special warranty document signed by a Director, General Manager or Vice President of Donaldson. Failure to use genuine Donaldson replacement parts may void this warranty. THERE EXIST NO OTHER REPRESENTATIONS, WARRANTIES OR GUARANTEES EXCEPT AS STATED IN THIS PARAGRAPH AND ALL OTHER WARRANTIES INCLUDING MERCHANTABILITY AND FITNESS FOR A PARTICULAR PURPOSE, WHETHER EXPRESS OR IMPLIED ARE HEREBY EXPRESSLY EXCLUDED AND DISCLAIMED.



Donaldson
FILTRATION SOLUTIONS

Parts and Service

For genuine Donaldson replacement filters and parts, call the Parts Express Line. For faster service, have unit's model and serial number, quantity, part number, and description available.

Donaldson Australasia
Tel: 1800 503 878 (AU)
Tel: 0800 743 387 (NZ)
Website: www.donaldsonfilters.com.au

Donaldson China
Tel: 400 820 1038
Website: www.donaldson.cn

Donaldson South Asia
Tel: +91 124 480 7536
Website: www.india.donaldson.com

Donaldson Japan
Tel: +81 42 540 4114
Website: www.donaldson.co.jp

Donaldson Korea
Tel: +82 251 733 33
Website: www.donaldson.co.kr

Donaldson Europe
Tel: +32 16 383 811
Website: www.donaldson.com

Donaldson Southeast Asia
Tel: +65 6349 8168
Website: www.asia.donaldson.com

Donaldson USA
Tel: +1 800 365 1331
Website: www.donaldson.com

Donaldson Company, Inc. is the leading designer and manufacturer of dust, mist, and fume collection equipment used to control industrial-air pollutants. Our equipment is designed to help reduce occupational hazards, lengthen machine life, reduce in-plant maintenance requirements, and improve product quality.