

Donaldson
Torit®

**DOWNFLO® OVAL
DUST COLLECTORS**

HIGH VACUUM DFO2-4

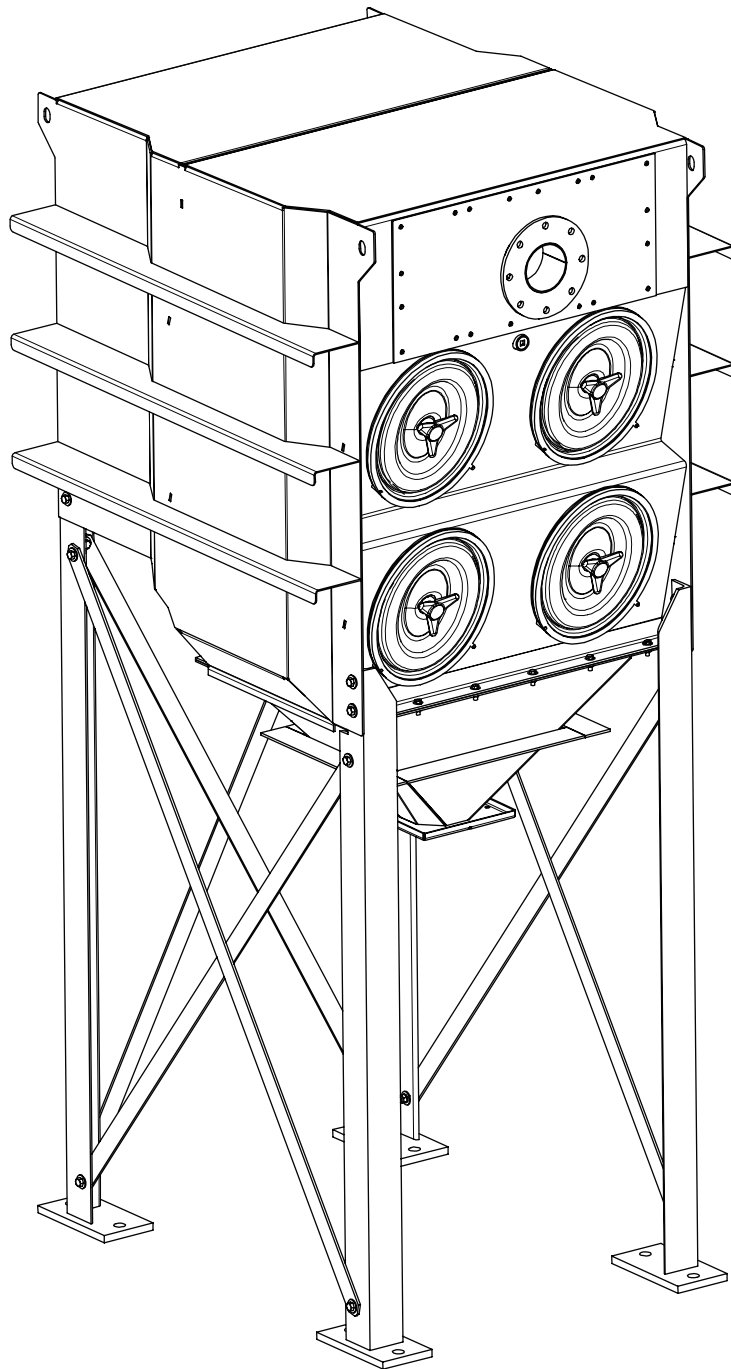

HIGH VACUUM DFO2-4 DUST COLLECTOR

The high vacuum DFO2-4 is derived from normal DFO2-4, so it has all the advantages of normal DFO serial products. In addition, it can bear -50kPa pressure by precise calculation and test in air lab.

It offers:

- Lower initial cost per cubic foot of air per minute
- Higher efficiency—cleaner air
- Lower pressure drop— greater energy savings
- Fewer filter changeouts
- Reduced filter disposal cost
- Easy system setup
- Less maintenance

NORMAL OPERATIONS

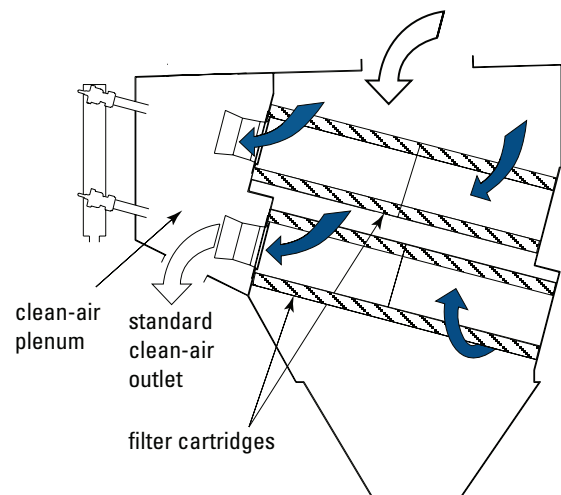

PULSE CLEANING TECHNOLOGY

ExtraLife Filter Cleaning System uses proprietary, computer-modeled pulse cleaning technology to easily “pulse off” dust from the surface of the filter, improving filtration efficiency and prolonging filter life. The red lines in the illustration show the increased pressure at the front of the Downflo filter generated by the ExtraLife system. The blue line shows the pulse signature of a standard cartridge collector.

Pulse gradients produced by the standard Downflo during pulse cleaning compared to gradients produced by a Downflo with the ExtraLife Cleaning System (red).

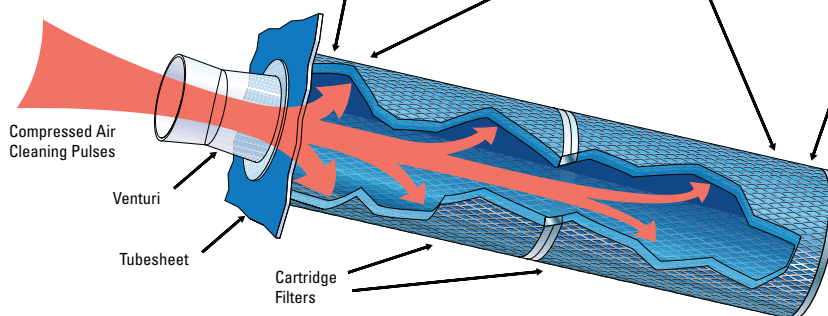
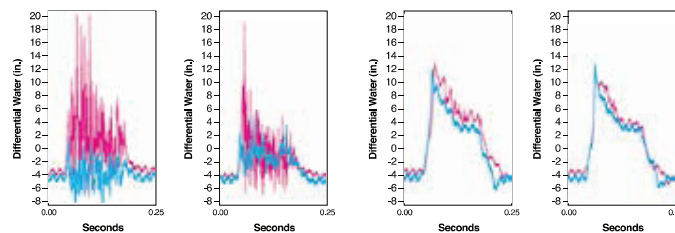

DOWNFLO PULSE PRESSURE GRADIENTS

DIMENSIONS & SPECIFICATIONS

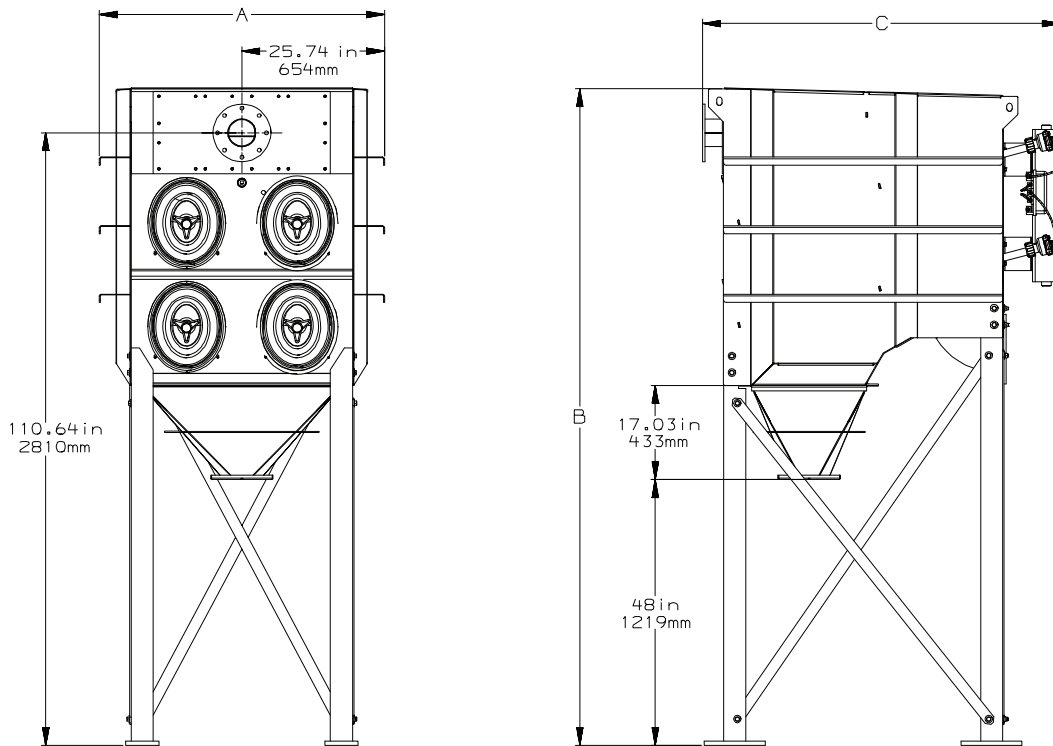

Model	Nominal Airflow Range**		No. of Filters	Ultra-Web Filter Area		No. of Valves	Approx. Shipping Weight***		Dimensions					
	cfm	m³/h		ft²	m²		lb	kg	A		B		C	
									in	mm	in	mm	in	mm
HV DF02-4	588-1176	1000-2000	4	760	70.6	4	1545	700	51.47	1307	118.61	3013	64.55	1640

** Based on clean filters.

*** Without accessories or optional equipment.

OPERATING ADVANTAGES & CONDITIONS

High vacuum DFO2-4	
Housing Rating (in of H ₂ O/mm of H ₂ O)	-197/-5000
Housing Construction	Strong 4.5-6 mm mild steel structure per GB standard
Seismic Spectral Acceleration	S _s = 1.5 S ₁ = 0.6
Wind Load Rating (mph/kph)	90/145
Compressed Air Required (psi/bar)	90/6.2
Operating Temperature	150°F/ 66°C
Electrical Power	220 VAC,
Valves/Controls	50/60 Hz

STANDARD FEATURES & AVAILABLE OPTIONS

High vacuum DFO2-4

Collector Design	Std	Opt
Mild Steel Construction	X	
ExtraLife™ Filter Cleaning System	X	
3-Lobe Knob Access Covers	X	
Inlets	X	
Explosion vent models (top mounted only)		X
Cartridge Filters		
Ultra-Web® (MERV* 15)	X	
Paint System		
Prime Coated Interior	X	
Textured Multi-Coat Paint Finish With 500-Hour Salt Spray Performance	X	
Textured Multi-Coat Paint Finish With 2000-Hour Salt Spray Performance		X
Custom Color		X
Epoxy Coating		X
Electrical Controls, Gauges & Enclosures		
Control Box w/Timer in NEMA 4 Enclosure	X	
Magnehelic®** Gauge	X	
Delta P-01 Controls		X
Solenoid Enclosure (NEMA 7 & 9)		X

* The Minimum Efficiency Reporting Value (MERV) of this filter cartridge has been determined through independent laboratory testing using ASHRAE 52.2 (2007) test standards. The MERV rating was determined at a face velocity of 118 feet (36.0 m) per minute and loading up to four inches (101.6 mm) water gauge. Actual efficiency of any filter cartridge will vary according to the specific application parameters. Dust concentration, airflow, particle characteristics, and pulse cleaning methods all affect filtration efficiency.

** Minihelic, Magnehelic are registered trademarks of Dwyer Instruments, Inc.

Global Support

- Facilities in 37 countries
- 40 manufacturing plants and 14 distribution centers

Leading Technology

- Over 1, 000 engineers and scientists worldwide
- Broad range of innovative collectors and filters
- 100s of filter media formulations

Experience and Service

- Technical expertise and support
- Ready-to-ship filters and parts within 24 hours
- 1, 000, 000+ dust, fume and mist collectors installed



Donaldson Australasia
Tel: 1800 503 878 (AU)
Tel: 0800 743 387 (NZ)
Website: www.donaldsonfilters.com.au

Donaldson China
Tel: 400 820 1038
Website: www.donaldson.cn

Donaldson South Asia
Tel: +91 124 480 7536
Website: www.india.donaldson.com

Donaldson Japan
Tel: +81 42 540 4114
Website: www.donaldson.co.jp

Donaldson Korea
Tel: +82 251 733 33
Website: www.donaldson.co.kr

Donaldson Europe
Tel: +32 16 383 811
Website: www.donaldson.com

Donaldson Southeast Asia
Tel: +65 6349 8168
Website: www.asia.donaldson.com

Donaldson USA
Tel: +1 800 365 1331
Website: www.donaldson.com

EXACTLY WHAT YOU NEED.™

Torit PowerCore Dust Collectors - HV DFO 2-4 Series (04/16)

© 2015 Donaldson Company, Inc. All Rights Reserved. All products, product specifications, and data (airflow, capacity, dimensions, or availability) are subject to change without notice, and may vary by region or country. Donaldson Torit, Torit PowerCore, Ultra-Web, and the color blue are registered trademarks of Donaldson Company, Inc. Contains Donaldson proprietary technology.