



Downflo® Evolution

DFE 2-8, 2-12, 3-12, 3-18, 3-24, 3-36, 3-48, 3-60, 3-72, 4-16, 4-24, 4-32, 4-48, 4-64, 4-80, 5-20, 5-30, 5-40, 5-60 and 5-80

Installation and Operation Manual

Installation, Operation, and Service Information

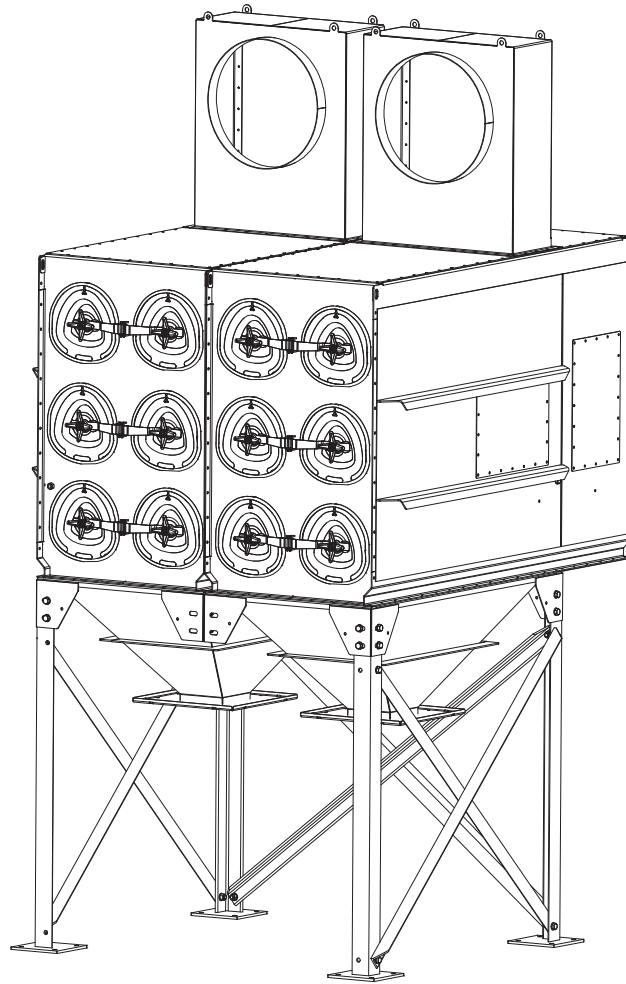

This manual is property of the owner. Leave with the collector when set-up and start-up are complete. Donaldson Company reserves the right to change design and specifications without prior notice.

Illustrations are for reference only as actual product may vary.



This is the safety alert symbol. It is used to alert you to potential personal injury hazards. Obey all safety messages that follow this symbol to avoid possible injury or death.



Process owners/operators have important responsibilities relating to combustible hazards. Process owners/operators must determine whether their process creates combustible dust, fume, or mist. If combustible dust, fume, or mist is generated, process owners/operators should at a minimum:

Comply with all applicable codes and standards. Among other considerations, current NFPA standards require owners/operators whose processes involve potentially combustible materials to have a current Hazard Analysis, which can serve as the foundation for their process hazard mitigation strategies.

Prevent all ignition sources from entering any dust collection equipment.

Design, select, and implement fire and explosion mitigation, suppression, and isolation strategies that are appropriate for the risks associated with their application.

Develop and implement maintenance work practices to maintain a safe operating environment, ensuring that combustible dust, fume, or mist does not accumulate within the plant.

Donaldson recommends process owners/operators consult with experts to insure each of these responsibilities are met.

As a manufacturer and supplier of Industrial Filtration Products, Donaldson can assist process owners/operators in the selection of filtration technologies. However, process owners/operators retain all responsibility for the suitability of fire and explosion hazard mitigation, suppression, and isolation strategies. Donaldson assumes no responsibility or liability for the suitability of any fire and/or explosion mitigation strategy, or any items incorporated into a collector as part of an owner/operators hazard mitigation strategy.

Improper operation of a dust control system may contribute to conditions in the work area or facility that could result in severe personal injury and product or property damage. Check that all collection equipment is properly selected and sized for the intended use.

DO NOT operate this equipment until you have read and understand the instruction warnings in the Installation and Operations Manual. For a replacement manual, contact Donaldson Torit.

This manual contains specific precautionary statements relative to worker safety. Read thoroughly and comply as directed. Discuss the use and application of this equipment with a Donaldson Torit representative. Instruct all personnel on safe use and maintenance procedures.

Data Sheet

Model Number _____	Serial Number _____
Ship Date _____	Installation Date _____
Customer Name _____	
Address _____ _____	
Filter Type _____	
Accessories _____	
Other _____	

Contents

Description.....	1	Maintenance Information	18
Purpose and Intended Use	1	Operational Checklist	18
Operation.....	3	Filter Removal and Installation.....	18
Inspection on Arrival.....	4	Filter Removal	19
Installation Codes and Procedures	4	Dust Disposal.....	19
Installation.....	4	Compressed Air Components.....	19
Foundations or Support Framing	5	Optional Equipment.....	21
Collector Location	5	Fan Blower	21
Site Selection	5	TBI and TRB Style Damper and Silencer Support	
Rigging Instructions.....	5	Bracket.....	22
Hoisting Information	5	Hopper Access	23
Typical Installation.....	6	55-Gallon Drum Pack.....	23
Standard Equipment.....	7	Rotary Valve and Transition.....	25
Field Assembly.....	7	Magnehelic® Gauge	26
Hopper Installation.....	7	Photohelic® Gauge	27
Leg Installation	7	Delta P Control.....	29
Provisional Anchor Bolt Recommendations.....	8	Delta P Plus Control	30
Module Assembly.....	9	Delta P C-01 Control	31
Yoke, Venturi and Filter Installation.....	11	Inlet Plenum	32
Compressed Air Installation	13	High Flow Inlet Plenum.....	33
Electrical Wiring.....	13	Extended Dirty-Air Plenum	33
Solid-State Timer Installation.....	15	Air Management Module.....	33
Solenoid Connection.....	15	Platforms and Ladders	34
Timer and Solenoid Specifications.....	15	Cold Climate Kit.....	35
Preliminary Start-Up Check	17	Explosion Vent	36
		Sprinkler.....	36
		Troubleshooting.....	37
		Appendix A-Clean Change	
		Bag-In/Bag-Out Filter and Liner System	A-1

Magnehelic® and Photohelic® are registered trademarks of Dwyer Instruments, Inc.



DANGER

DANGER indicates a hazardous situation which, if not avoided, will result in death or serious injury.



WARNING

WARNING indicates a hazardous situation which, if not avoided, could result in death or serious injury.



CAUTION

CAUTION, used with the safety alert symbol, indicates a hazardous situation which, if not avoided, could result in minor or moderate injury.

NOTICE

NOTICE is used to address practices not related to personal injury that may result in damage to equipment.

Description

The Downflo® Evolution dust collector is a continuous-duty, modular collector with cartridge-style filters. The downward airflow design delivers high filtration efficiency while using less energy. Continuous duty means the filters can be pulse cleaned on-line without interrupting airflow through the collector. The filters are pulse-cleaned in sequence, one set at a time, without turning the collector off. The modular design allows flexibility so the collector can be adapted easily to limited space areas. Each standard module filter can be two or three filter columns wide by two, three, four, or five filter rows high by two filters deep.

Purpose and Intended Use



WARNING

Misuse or modification may result in severe personal injury and/or property damage.

Do not misuse or modify.

Downflo Evolution collectors are intended for filtration of nuisance dust where the dust loading to the collector is less than five grains per cubic foot. Some typical applications include metal grinding, plasma cutting, dry bulk, pharmaceutical, thermal spray, welding, metal manufacturing, glass, and food processing. Each application is different and selecting the correct filter for the application and dust being collected is important. Contact Donaldson Torit for selection assistance.

Ambient, extremely fine, and non-fibrous dusts, typically are well served by Ultra Web® filters which offer high efficiency and performance on fine particulate.

Fibrous dusts often benefit from a filter with an open-pleat design, such as Fibra-Web®.

Operations involving high temperature and high humidity may require special attention. Temperature, moisture content, and chemistry issues may also require custom collector design.

Hygroscopic dust such as fertilizer, salt, and sugar should be handled under a controlled, low humidity environment.

Flammable or explosive dust may require customized collector design options.

Applications with high hydrocarbon or high oil content may require special treatment or filter media.



WARNING

Combustible materials such as buffing lint, paper, wood, metal dusts, weld fume, or flammable coolants or solvents represent potential fire and/or explosion hazards. Use special care when selecting, installing, and operating all dust, fume, or mist collection equipment when such combustible materials may be present in order to protect workers and property from serious injury or damage due to a fire and/or explosion.

Consult and comply with all National and Local Codes related to fire and/or explosion properties of combustible materials when determining the location and operation of all dust, fume, or mist collection equipment.

Standard Donaldson Torit equipment is not equipped with fire extinguishing or explosion protection systems.

Rating and Specification Information

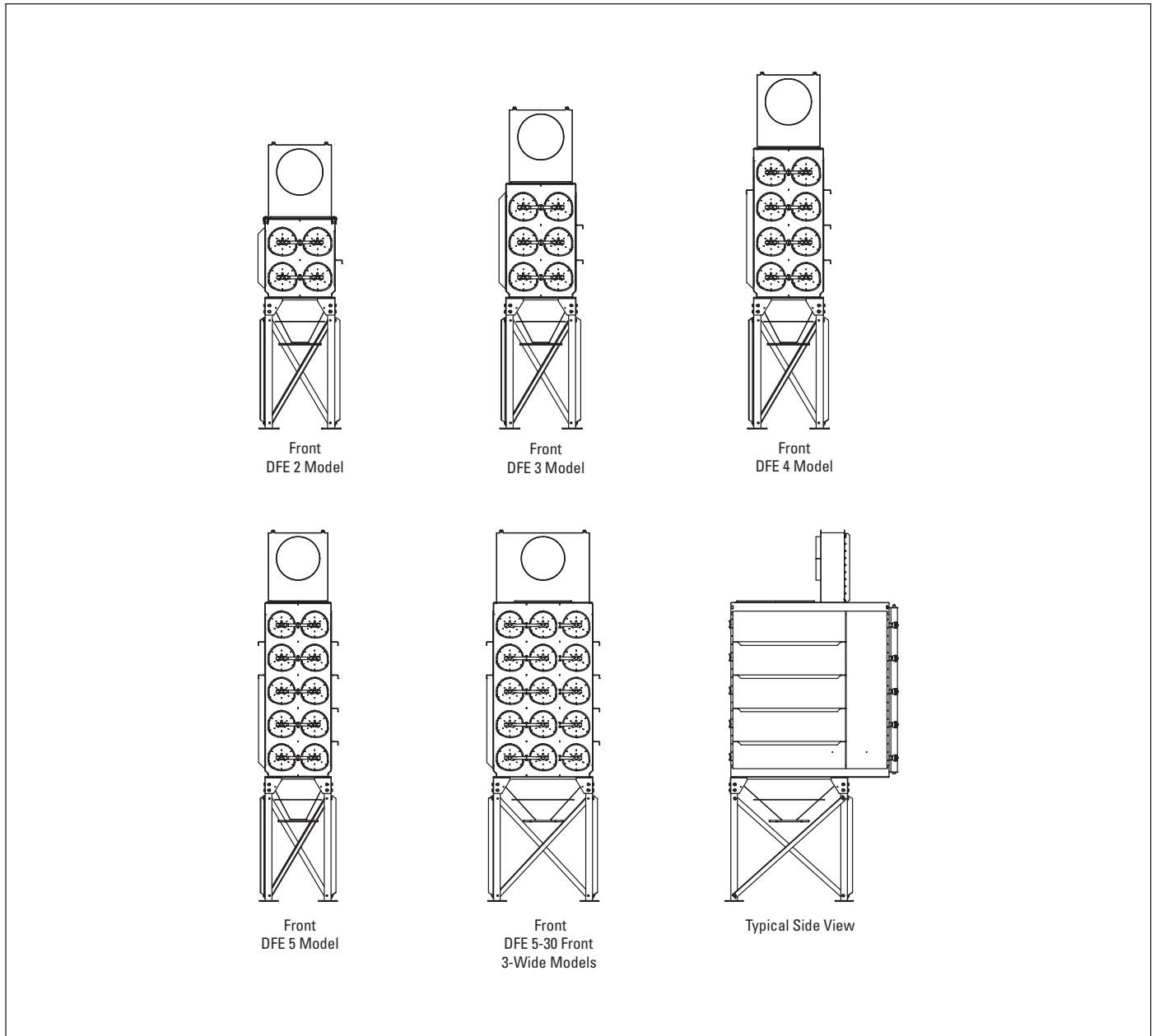

Collectors are rated for the following loads as calculated per relevant sections of the IBC 2009 code*:

Basic Wind Speed & Exposure90 mph, Exposure C
 Seismic Spectral Acceleration, S 1.5 g
 Seismic Spectral Acceleration, S^s 0.6 g
 Installed Collector Base Elevation.....Grade
 Occupancy Category..... II
 Compressed air, maximum psig.....90
 Housing rating, inches water gauge+10/-25
 Control power.....120/220 Volt 50/60 Hz

*If collector was supplied with a Record Drawing, the specifications on the drawing will supersede the standard specifications above.

Operation

During normal operation, dust-laden air enters the collector through the dirty-air inlet, which is positioned over the venturi section of the dirty air plenum. Airflow is directed downward through the collector over the venturis and heavier particulate falls directly into the hopper. The filters remove fine particulate allowing filtered air to pass through the filters to the clean-air plenum where it discharges through the clean-air outlet.

Filter cleaning is completed using pulse-jet technology. A solenoid and diaphragm valve aligned to each row of filters provides the pulse cleaning. The cleaning sequence starts at the top filter row and continues down through each module. Removal, inspection, or replacement of filters can be accomplished from outside the collector by removing the filter access cover and sliding the filters out.

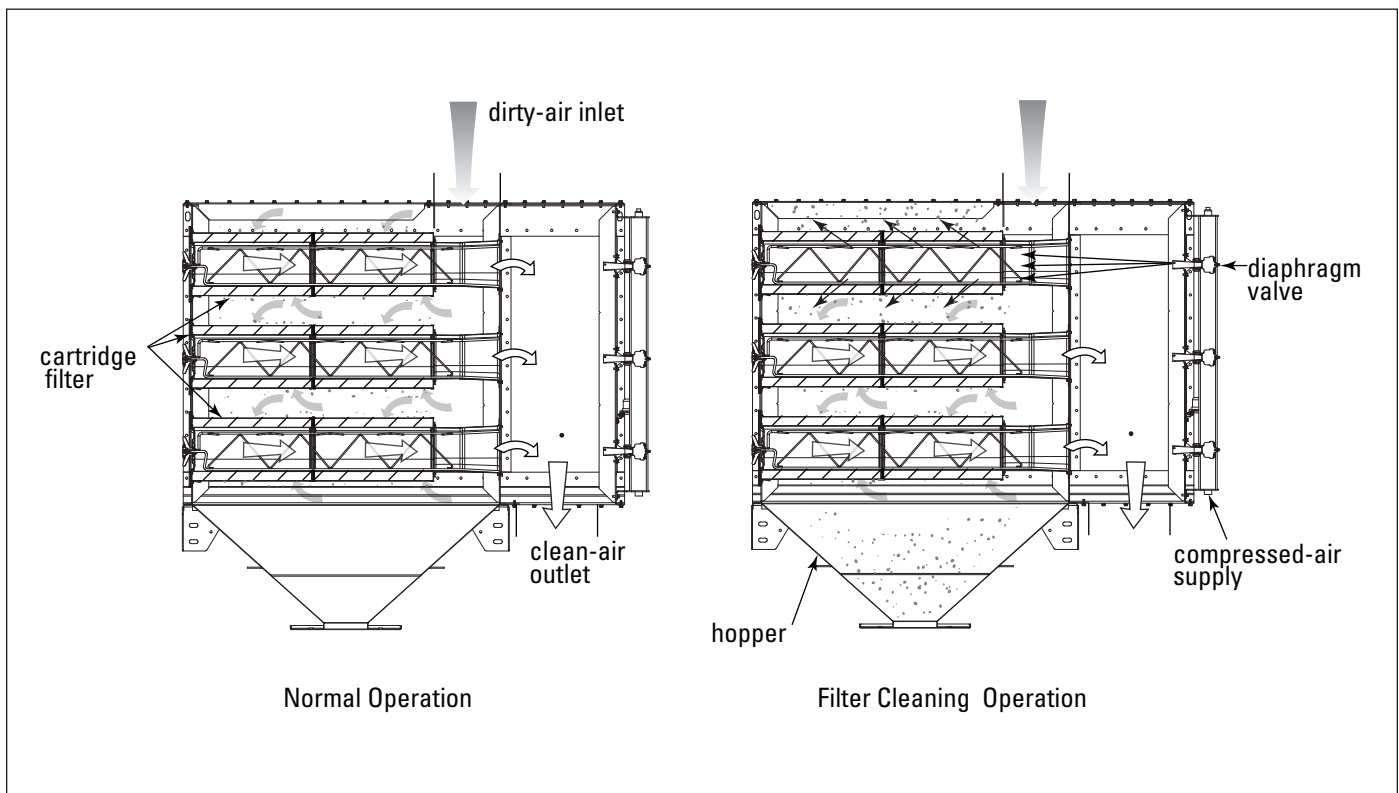

Collector Operation

Inspection on Arrival

1. Inspect collector upon delivery.
2. Report any damage to the delivery carrier.
3. Request a written inspection report from the Claims Inspector to substantiate any damage claim.
4. File claims with the delivery carrier.
5. Compare collector received with description of product ordered.
6. Report incomplete shipments to the delivery carrier and your Donaldson Torit representative.
7. Remove crates and shipping straps. Remove loose components and accessory packages before lifting collector from truck.
8. Check for hardware that may have loosened during shipping.
9. Use caution removing temporary covers.

Installation Codes and Procedures



Codes may regulate recirculating filtered air in your facility.

Consult with the appropriate authorities having jurisdiction to ensure compliance with all national and local codes regarding recirculating filtered air.

Safe and efficient operation of the collector depends on proper installation.

Authorities with jurisdiction should be consulted before installing to verify local codes and installation procedures. In the absence of such codes, install collector according to the National Electric Code, NFPA No. 70-latest edition and NFPA 91 (NFPA 654 if combustible dust is present).

A qualified installation and service agent must complete installation and service of this equipment.

All shipping materials, including shipping covers, must be removed from the collector prior to or during collector installation.

NOTICE

Failure to remove shipping materials from the collector will compromise collector performance.

Inspect collector to ensure all hardware is properly installed and tight prior to operating collector.

Installation



Use proper equipment and adopt all safety precautions needed for servicing equipment.

Electrical service or maintenance work must be performed by a qualified electrician and comply with all applicable national and local codes.

Turn power off and lock out electrical power sources before performing service or maintenance work.

Do not install in classified hazardous atmospheres without an enclosure rated for the application.

Turn compressed air supply OFF, bleed and lock out lines before performing service or maintenance work.



Site selection must account for wind, seismic zone, and other

load conditions when selecting the location for collectors.

Codes may regulate acceptable locations for installing dust collectors. Consult with the appropriate authorities having jurisdiction to ensure compliance with all national and local codes regarding dust collector installation.

Collectors must be anchored in a manner consistent with local code requirements. Anchors must be sufficient to support dead, live, seismic, and other anticipated loads.

Consult a qualified engineer for final selection of anchorage.

NOTICE

Do not set compressed-air pressure above 90-psig as component damage can occur.

All compressed air components must be sized to meet the maximum system requirements of 90-psig supply pressure.

The compressed-air supply must be oil and moisture free. Contamination in the compressed air used to clean filters will result in poor cleaning, cleaning valve failure, or poor collector performance.

Purge compressed air lines to remove debris before connecting to the collector's compressed air manifold.

The collector is suitable for either indoors or outdoor installations. Reference the Rating and Specification Information.

Foundations or Support Framing

Prepare the foundation or support framing in the selected location. Foundation or support framing must comply with local code requirements and may require engineering.

Foundation and support framing must be capable of supporting dead, live, wind, seismic and other applicable loads. Consult a qualified engineer for final selection of foundation or support framing.

Collector Location

WARNING Donaldson Torit equipment is not designed to support site installed ducts, interconnecting piping, or electrical services. All ducts, piping, or electrical services must be adequately supported to prevent severe personal injury and/or property damage.

When hazardous conditions or materials are present, consult with local authorities for the proper location of the collector.

CAUTION Dust collection equipment may reach peak sound pressure levels above 80 dB (A). Noise levels should be considered when selecting collector location.

Locate the collector to ensure easy access to electrical and compressed air connections, to simplify solids collection container handling and routine maintenance, and to ensure the straightest inlet and outlet ducts.

Site Selection

This collector can be located on a foundation or structural framing.

Provide clearance from heat sources and avoid any interference with utilities when selecting the location.

Rigging Instructions

Suggested Tools & Equipment

Clevis Pins and Clamps	Lifting Slings
Crane or Forklift	Pipe Sealant
Drift Pins	Pipe Wrenches
Drill and Drill Bits	Screwdrivers
End Wrenches	Socket Wrenches
Adjustable Wrench	Spreader Bars
Torque Wrench (inch/lbs, 9/16-in Socket)	

Hoisting Information

WARNING

Failure to lift the collector correctly can result in severe personal injury and/or property damage.

Use appropriate lifting equipment and adopt all safety precautions needed for moving and handling the equipment.

A crane or forklift is recommended for unloading, assembly, and installation of the collector.

Location must be clear of all obstructions, such as utility lines or roof overhang.

Use all lifting points provided.

Use clevis connectors, not hooks, on lifting slings.

Use spreader bars to prevent damage to collector's casing.

Check the Specification Control drawing for weight and dimensions of the collector and components to ensure adequate crane capacity.

Allow only qualified crane or forklift operators to lift the equipment.

Refer to local codes when using cranes, forklifts, and other lifting equipment.

Lift collector and accessories separately and assemble after collector is in place.

Use drift pins to align holes in section flanges during assembly.

Typical Installation

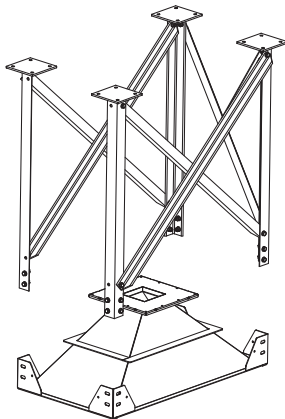

Steps 1-2

1. Place hopper discharge-side up on ground or other level surface and attach legs to hopper.
2. Assemble leg cross braces.
3. Turn hopper and leg assembly over and lift into position over anchor bolts.
4. Level hopper.
5. Tighten all fasteners securely, including all anchor bolts.

CAUTION Tighten all hardware before removing crane.

- 6.* Apply 1/4-in diameter rope-type sealant to hopper flange.
7. Lift unit over leg and hopper assembly and lower slowly.
8. Secure with bolts, washers, and nuts supplied.
- 9.* Apply 1/4-in diameter rope-type sealant around inlet opening.
10. Lift inlet onto collector. Secure with bolts, washers, and nuts supplied.

CAUTION Tighten all hardware before removing crane.

11. Remove crane.
- 12.* Apply sealant to hopper/cabinet and cabinet/inlet seam.

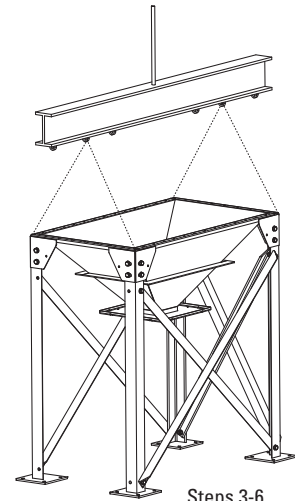

Steps 3-6

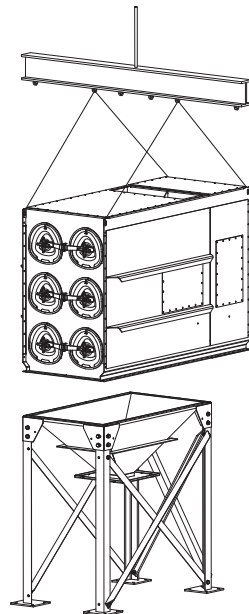

Steps 7-9

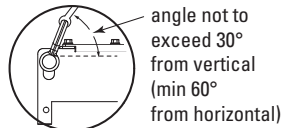

angle not to exceed 30° from vertical (min 60° from horizontal)



Do Not lift with this orientation

*Apply 1/4-in diameter rope-type sealant after marriage of hopper to cabinet and cabinet to inlet (steps 7-10 and 12)

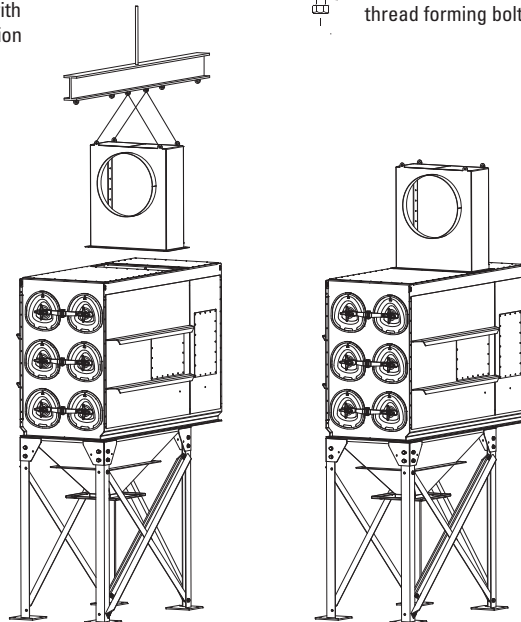
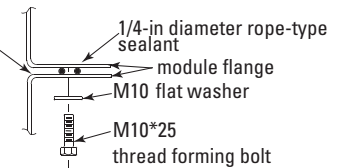

Step 10

*The 1/4-in diameter rope-type sealant supplied with the collector is temperature sensitive. It may soften and become difficult to work with at elevated temperatures. Store rope-type sealant in a cool location before use.

Typical Installation

Standard Equipment

Standard Downflo Evolution collectors consist of collector modules, inlet boxes, hoppers, and legs. The legs and hopper are assembled first and the collector is placed in position using a crane or forklift.

Field Assembly

WARNING

Use proper equipment and adopt all safety precautions needed for servicing equipment.

Electrical service or maintenance work must be performed by a qualified electrician and comply with all applicable national and local codes.

Turn power off and lock out electrical power sources before performing service or maintenance work.

Do not install in classified hazardous atmospheres without an enclosure rated for the application.

Turn compressed air supply OFF, bleed and lock out lines before performing service or maintenance work.

Field assembly of collector may be required due to truck capacity, crane capacity, or specific customer requirements. A detailed instruction drawing, shipped with each collector will provide specific assembly and lifting instructions.

Hopper Installation

There are four hopper styles offered for the Downflo Evolution. A single module hopper spanning a single collector module with two or three filter columns. A double module hopper spanning a pair of collector modules with two filter columns thereby accommodating four filter columns. A taller, steeper, single module hopper spanning one collector module with two filter columns. A single module screw conveyor hopper spanning one collector module with two filter columns. All four hopper styles except the screw conveyor hopper provide a 10-inch square discharge opening. The screw conveyor hopper provides a single 18-inch discharge opening.

Leg Installation

WARNING

Anchors must comply with local code requirements and must be capable of supporting dead, live, wind, seismic, and other applicable loads.

Anchor sizes shown are provisional, as final anchor sizing will depend on job site load conditions, collector location, foundation/framing design variables and local codes.

Consult a qualified engineer for final selection of suitable anchors.

Leg sets for standard collector sizes are shown in the Rating and Specification Information. Reference Typical Foundation Anchor and leg assembly drawing shipped with the collector prior to starting assembly.

1. Prepare the foundation or support framing in the selected location. Locate and install anchors.
2. Set the hopper on the ground or a flat surface with the collector connection flange down. The discharge opening on the hopper base should be oriented up.
3. Use drift pins to align holes.
4. Reference the Leg Positioning and Leg and Cross Brace Assembly drawings. Attach the legs to the hopper gussets using the hardware supplied.
5. Join multiple hoppers together at hopper gussets using the hardware supplied. Do not tighten hardware at this time.
6. Turn leg and hopper assembly over and position over anchor bolts. Secure each leg pad to the foundation anchor bolts with customer-supplied flat washers, lock washers, and nuts. Do not tighten hardware at this time.
7. Level hopper.
8. Tighten all hardware securing legs, cross braces, hopper gussets, and foundation anchor bolts.

CAUTION

Tighten all hardware before removing crane.

Provisional Anchor Bolt Recommendations

1. Consider Hilti HIT-HY 200 Anchor System or equivalent. Quantity of anchor bolts should match the number of holes provided in the base plates.
2. Anchor diameter is typically 1/8-in less than baseplate hole diameter.
3. Corrosive environment or outdoor installation may require stainless steel anchors.

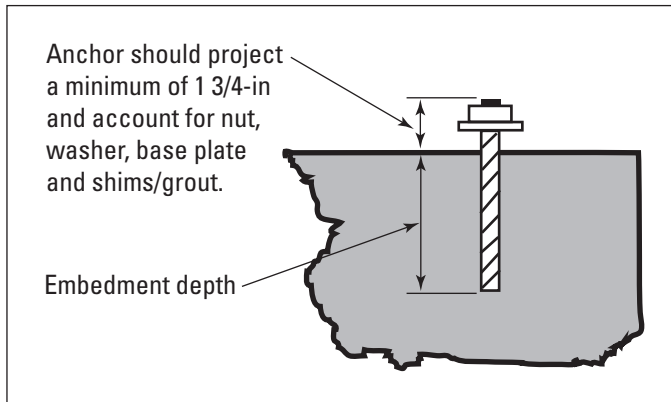

Typical Foundation Anchor

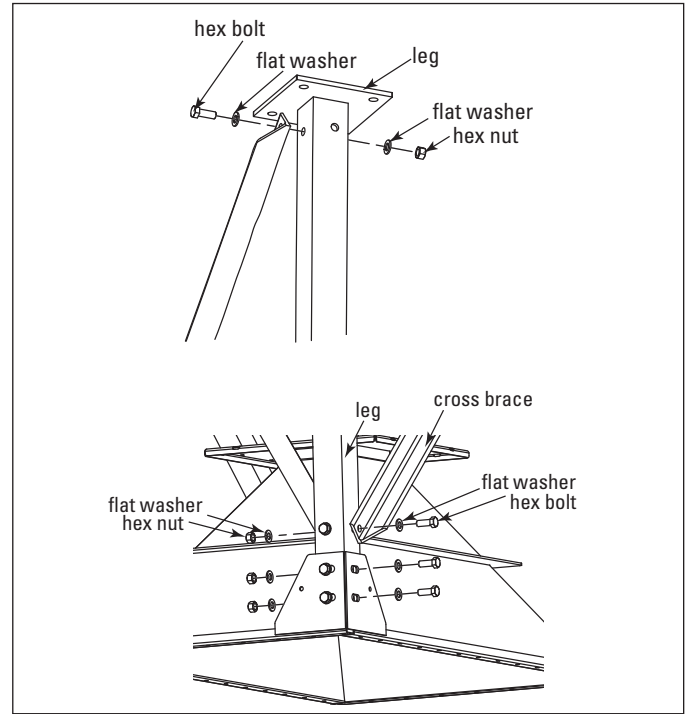

Leg and Cross Brace Assembly

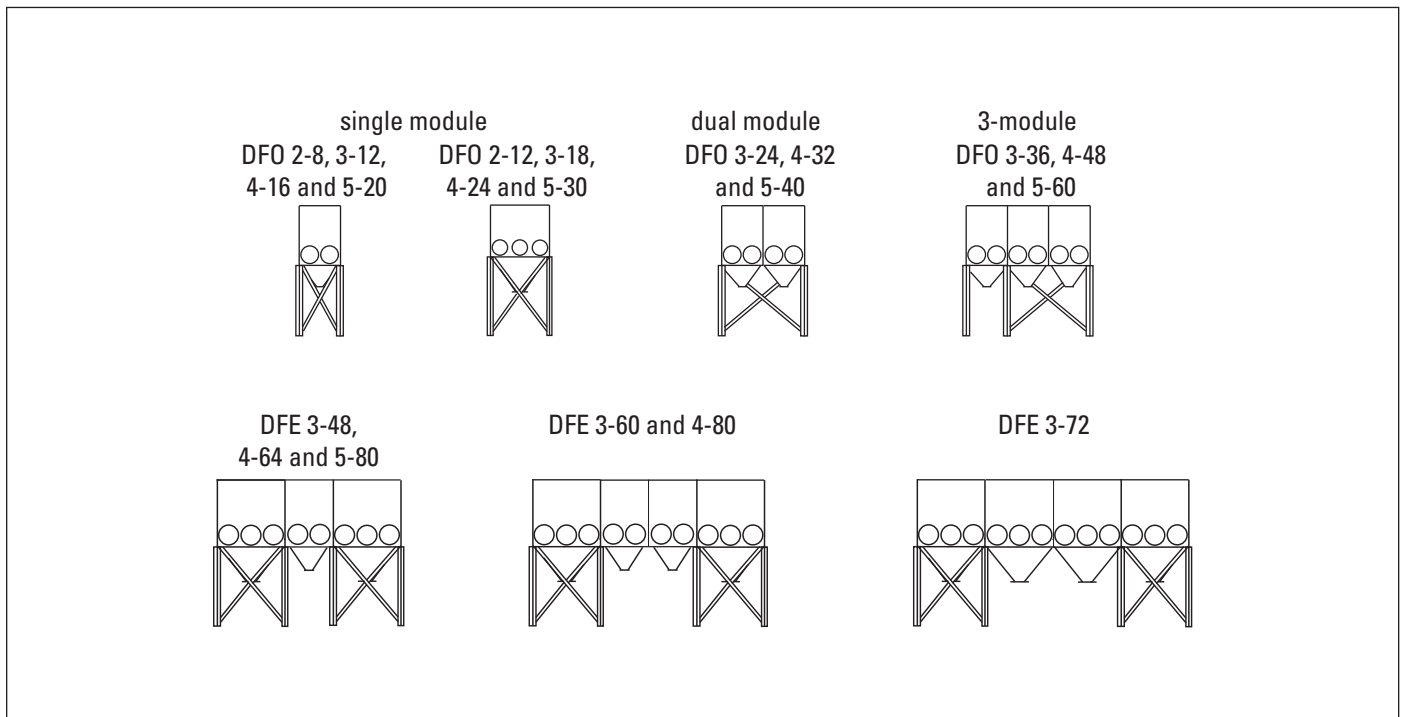

Leg Positioning

Module Assembly

Two cranes are required to lift and assemble modules.

1. Remove the protective cover from the end of each module.
2. Remove one column of access covers, filters, venturis, and yokes from the joint side of each module as shown in Detail A.
3. Remove outlet cover from the bottom of the clean-air plenum and set aside.
4. Apply a generous amount of sealant to one module to create an airtight seal between the clean- and dirty-air plenums as shown in Detail B.
5. Lift both modules into position using two cranes.
6. Use drift pins to align the bolt holes in the mating flanges.

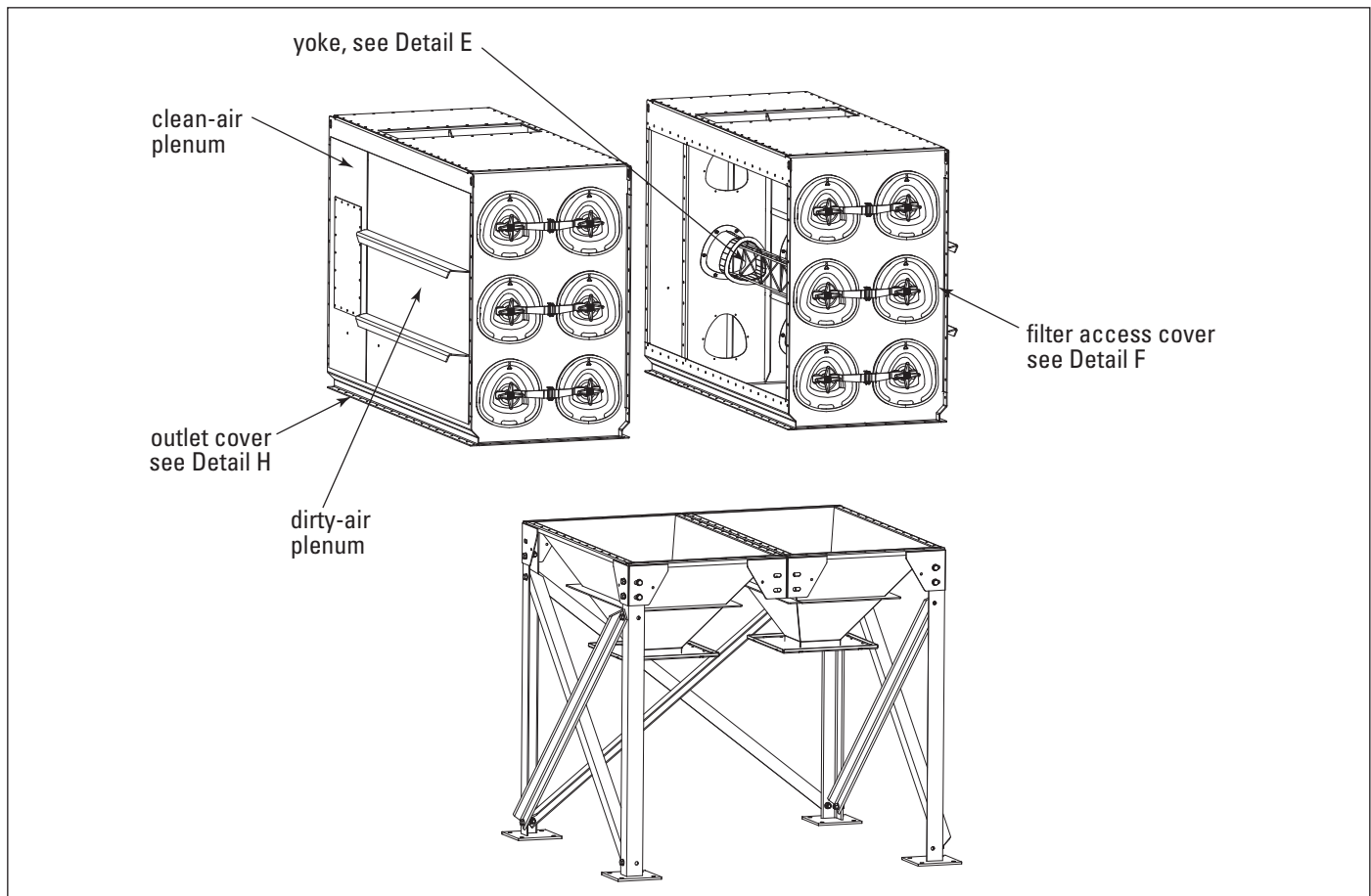

Detail A

7. Bolt the modules together using 1/2-13 and M10 *25 bolts, washers and nuts as shown in Details B, C and D. Do not tighten hardware at this time.

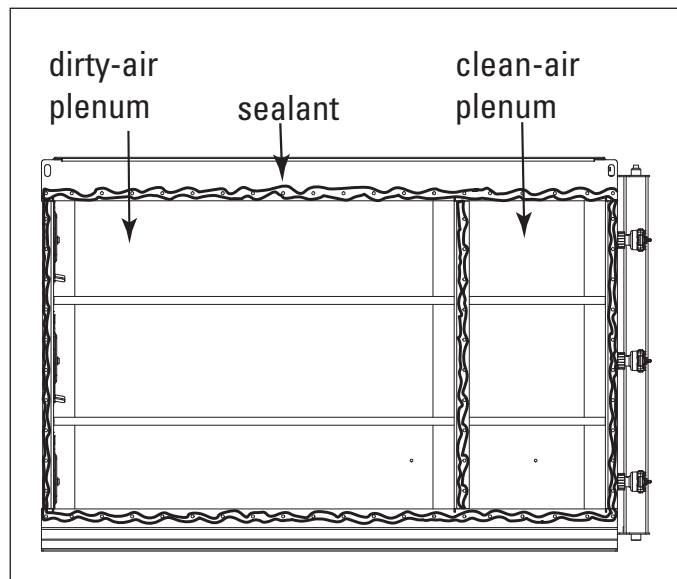

Detail B

8. Check that all joints and flanges are flush and tighten hardware starting with the joint between the clean- and dirty-air plenums. Remove excess sealant.

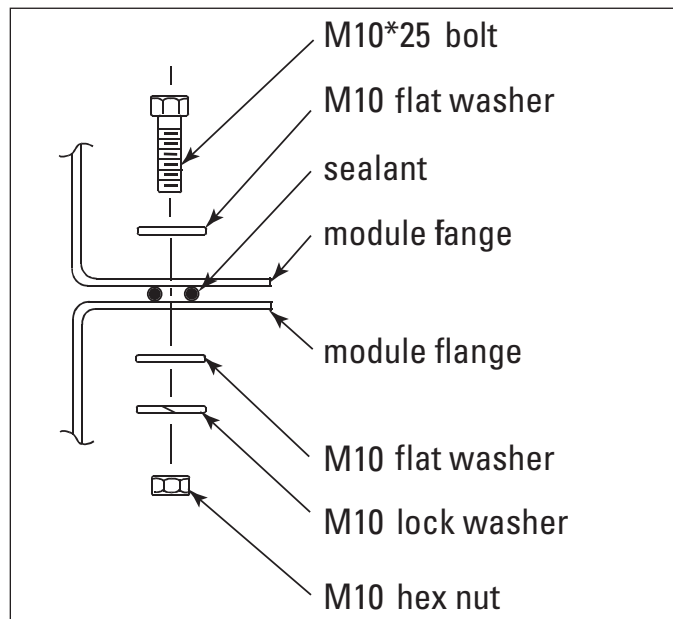

Detail D

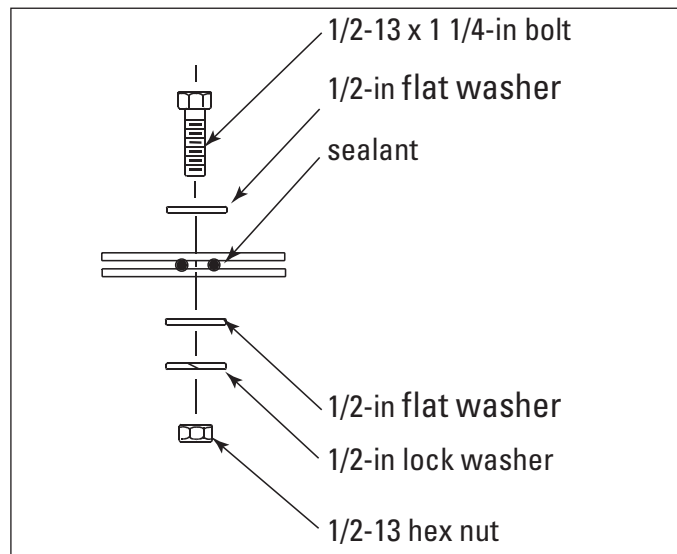

Detail C

Yoke, Venturi and Filter Installation

NOTICE

Installing yokes requires two people.

1. From the clean air plenum (to access, remove the outlet cover, see Detail I), thread a M10 hex jam nut and M10 flat washer to the shoulder of each of the three yoke rod ends. See Detail G.
2. Starting at the top access port work downward. Orient the yoke as shown in Detail E and insert into the housing so the yoke is positioned in the appropriate holes in the tube sheet. From the filter section, have one person hold the yoke in position while another person installs a M10 flat washer and M10 hex nut on each yoke rod end from the clean-air plenum. Do not tighten hardware at this time.
3. Adjust jam nut against the filter cartridge panel. Have one person hold the yoke in position as shown in Detail F while another person tightens the three hex nuts from the clean-air plenum. Repeat to install all yokes.
4. Apply sealant to venturi as shown in Detail H. Slide venturi over the yoke with sealant end first. Hold venturi in place while installing venturi hardware (M8*25 screws and M8 gasket washers) from the clean-air plenum.
5. Slide the filter cartridges into the collector on the yoke gasket-end first. Replace access cover and tighten securely by hand following instructions found in Maintenance Information. Repeat for all filter cartridges.
6. Replace the outlet cover on the bottom of the clean-air plenum shown in Detail I.

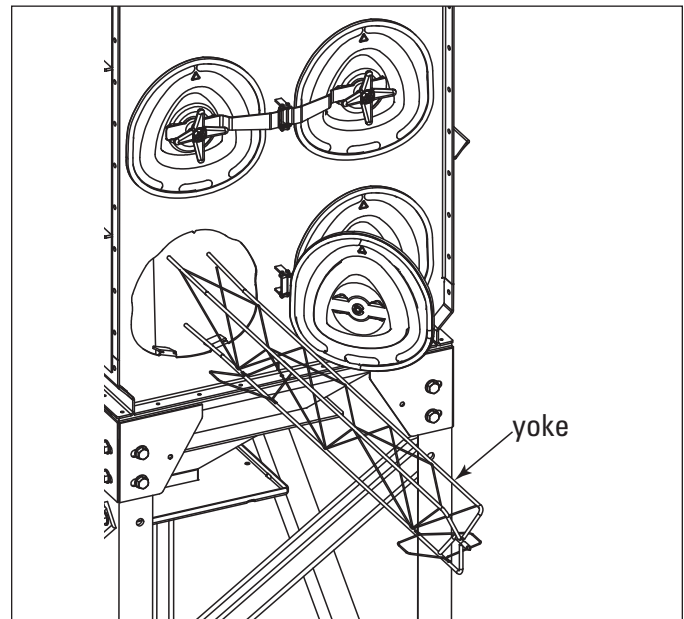

Detail E

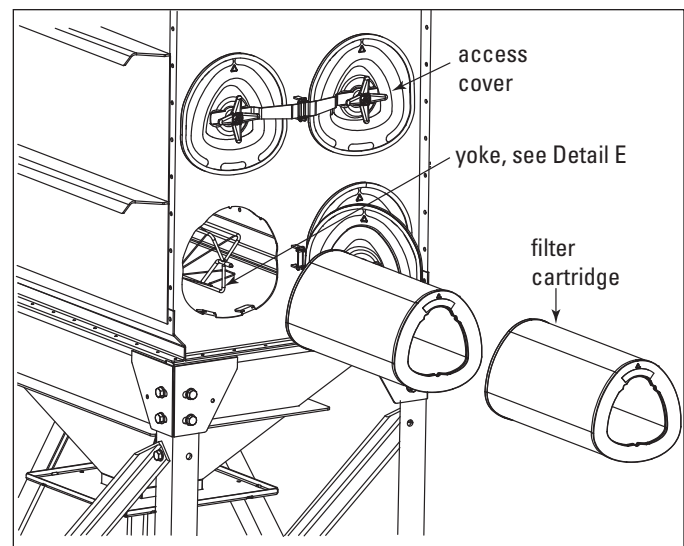

Detail F

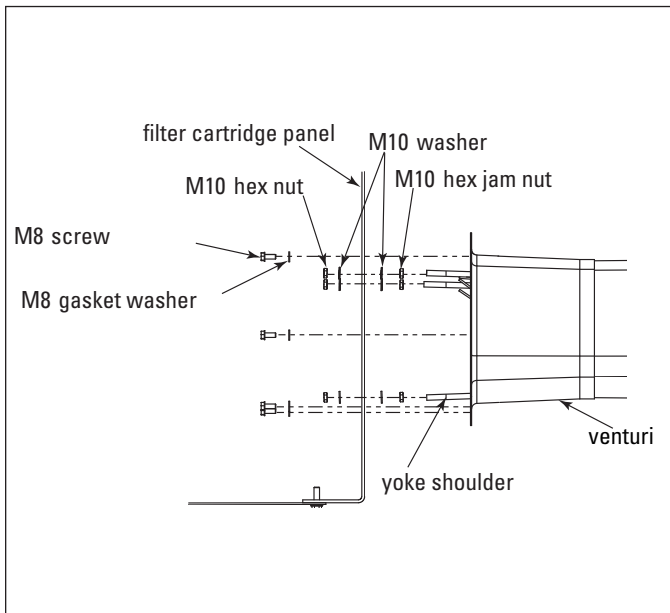

Detail G

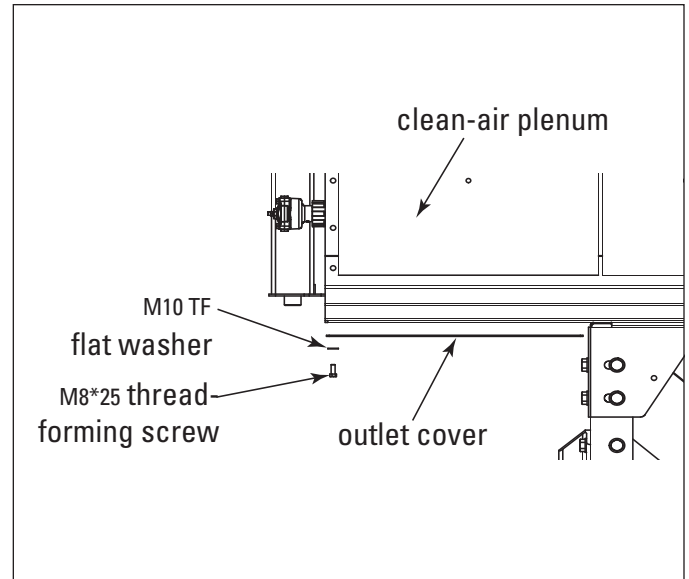

Detail I

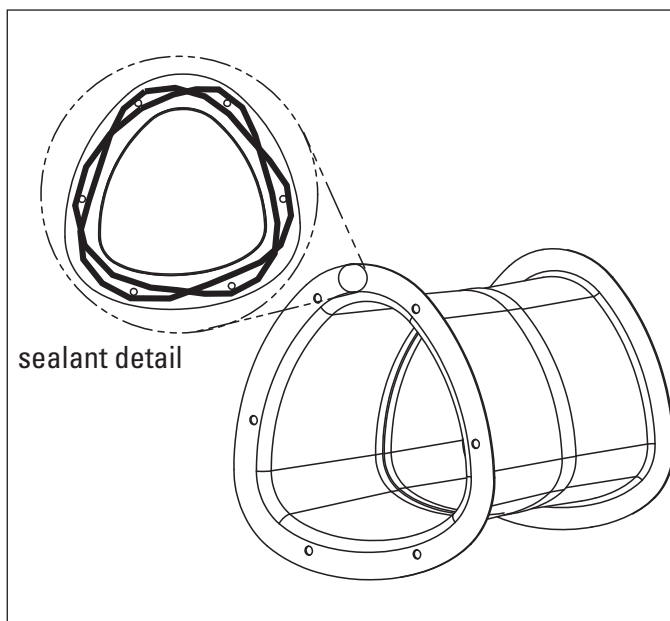

Detail H

Compressed Air Installation

WARNING

Turn compressed air supply OFF, bleed and lock out lines before performing service or maintenance work.

A safety exhaust valve should be used to isolate the compressed air supply. The safety exhaust valve should completely exhaust pressure in the collector manifolds when closed, should be capable of being interlocked with fire or explosion mitigation equipment and should include provisions to allow closed-position locking.

NOTICE

Do not set compressed-air pressure above 90-psig as component damage can occur.

All compressed air components must be sized to meet the system requirements of 90-psig supply pressure.

The compressed-air supply must be oil and moisture free. Contamination in the compressed air used to clean filters will result in poor cleaning, cleaning valve failure, or poor collector performance.

Purge compressed-air lines to remove debris before connecting to the collector's compressed-air manifold.

1. Remove the plastic pipe plug from the collector's air manifold and connect the compressed-air supply lines. Use thread-sealing tape or pipe sealant on all compressed-air connections.
2. Install a customer-supplied shut-off valve, bleed-type regulator with gauge, filter, and automatic condensate valve in the compressed-air supply line.
3. Set compressed-air supply to 90-psig. The pulse-cleaning controls are factory set to clean one or more filters every 10-seconds during a cleaning cycle.

Electrical Wiring

WARNING

Electrical installation, service, or maintenance work must

be performed by a qualified electrician and comply with all applicable national and local codes.

Turn power off and lock out electrical power sources before performing service or maintenance work.

Do not install in classified hazardous atmospheres without an enclosure rated for the application.

All electrical wiring and connections, including electrical grounding, should be made in accordance with the National Electric Code (NFPA No. 70-latest edition).

Check local ordinances for additional requirements that apply.

The appropriate wiring schematic and electrical rating must be used. See collector's rating plate for required voltage.

An electric disconnect switch having adequate amp capacity shall be installed in accordance with Part IX, Article 430 of the National Electrical Code (NFPA No. 70-latest edition). Check collector's rating plate for voltage and amperage ratings.

Refer to the wiring diagram for the number of wires required for main power wiring and remote wiring.

WARNING

Turn power off and lock out electrical power sources.

Turn compressed-air supply OFF, bleed and lock out lines before performing service or maintenance work.

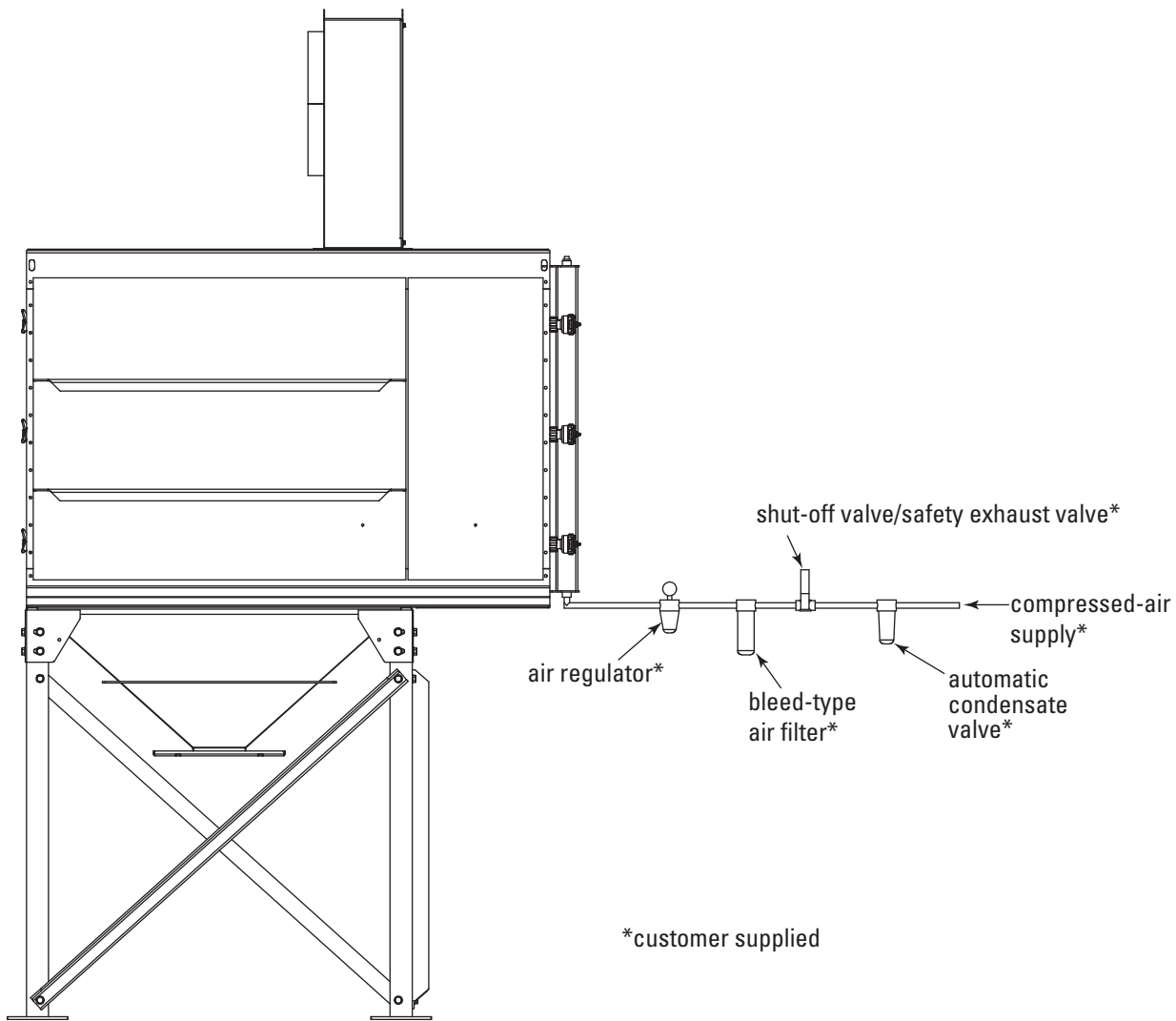

Compressed Air and Component Installation

Solid-State Timer Installation

WARNING

Electrical installation, service or maintenance work during installation must be performed by a qualified electrician and comply with all applicable national and local codes.

Turn power off and lock out electrical power sources before performing installation, service, or maintenance work.

Do not install in classified hazardous atmospheres without an enclosure rated for the application.

The solid-state timer is used to control the filter cleaning system. Available options include 3, 6, 10, 20, or 32-pin solenoid valve controls.

1. Using the wiring diagram supplied, wire the fan motor, fan-motor starter, solid-state timer, and solenoid valves. Use appropriate wire gauge for rated amp load as specified by local codes.
2. Plug the program lug into the pin that corresponds with the number of solenoid valves controlled. For 20 and 32 PIN solenoid controls, set the switch positions on the DIP switch labeled LAST CHANNEL to the corresponding number of pulse valves using the chart printed on the timer board.
3. With power supply ON, check the operation of the timer and valves. The valves should open and close sequentially at factory set 10-second intervals.
4. If a gauge or similar device is used to control the solid-state timer, the jumper on the pressure switch portion of the timer should be removed. The solenoid valves pulse only when the differential pressure reaches the high-pressure setpoint. The valves will continue to pulse until the low-pressure setpoint is reached.

NOTICE

The solid-state timer voltage must match the voltage of the rating of the timer provided (typically 120VAC, 240 VAC also available).

Do not mount the solid-state timer directly to the collector as mechanical vibration can damage the timer.

Solenoid Connection

The collector is equipped with electric solenoid valves (typically 120V) that controls the pulse-cleaning valves, which in turn clean the filters.

Solenoid enclosures are mounted near or on the collector's compressed-air manifold.

Wire the solenoids to the solid-state timer following the wiring diagram supplied with the collector. Filter life and cleaning operation will be affected if not wired correctly.

Timer and Solenoid Specifications

Power to the solid-state timer is supplied to Terminals L1 and L2, which are intended to operate in parallel with the fan starter's low-voltage coil. On fan start-up, power is supplied to the timer and the preset OFF time is initiated. At the end of the OFF time, the timer energizes the corresponding solenoid valve to provide the ON time cleaning pulse for one diaphragm valve and then steps to the next until all filters have been cleaned.

To pulse when the fan is OFF, install a toggle switch as shown on the Solid-State Timer Wiring Diagram. When the toggle switch is ON, the timer receives power and energizes the solenoid valves' pulse-cleaning operation even though the fan is turned OFF.

Input
220V/50-60Hz/1Ph

Output Solenoids
The load is carried and turned ON and OFF by the 200 watt maximum-load-per-output solid-state switch.

Pulse ON Time
Factory set at 100-milliseconds, or 1/10-second.

NOTICE Do not adjust pulse ON time unless the proper test equipment is available. Too much or too little ON time can cause shortened filter life.

Pulse OFF Time
Factory set at 10-seconds, adjustable from 1.5-sec minimum to maximum 30-seconds.

Operating Temperature Range
-20° F to 130° F

Transient Voltage Protection
50 kW transient volts for 20-millisecond duration once every 20 seconds, 1% duty cycle.

Solenoid Valves
220-Volt at 19.7 watts each

Compressed-Air
Set compressed-air supply at 90-psig. The timer is factory set to clean one set of filters every 10-seconds.

NOTICE Do not increase supply pressure above 90-psig as component damage can occur.

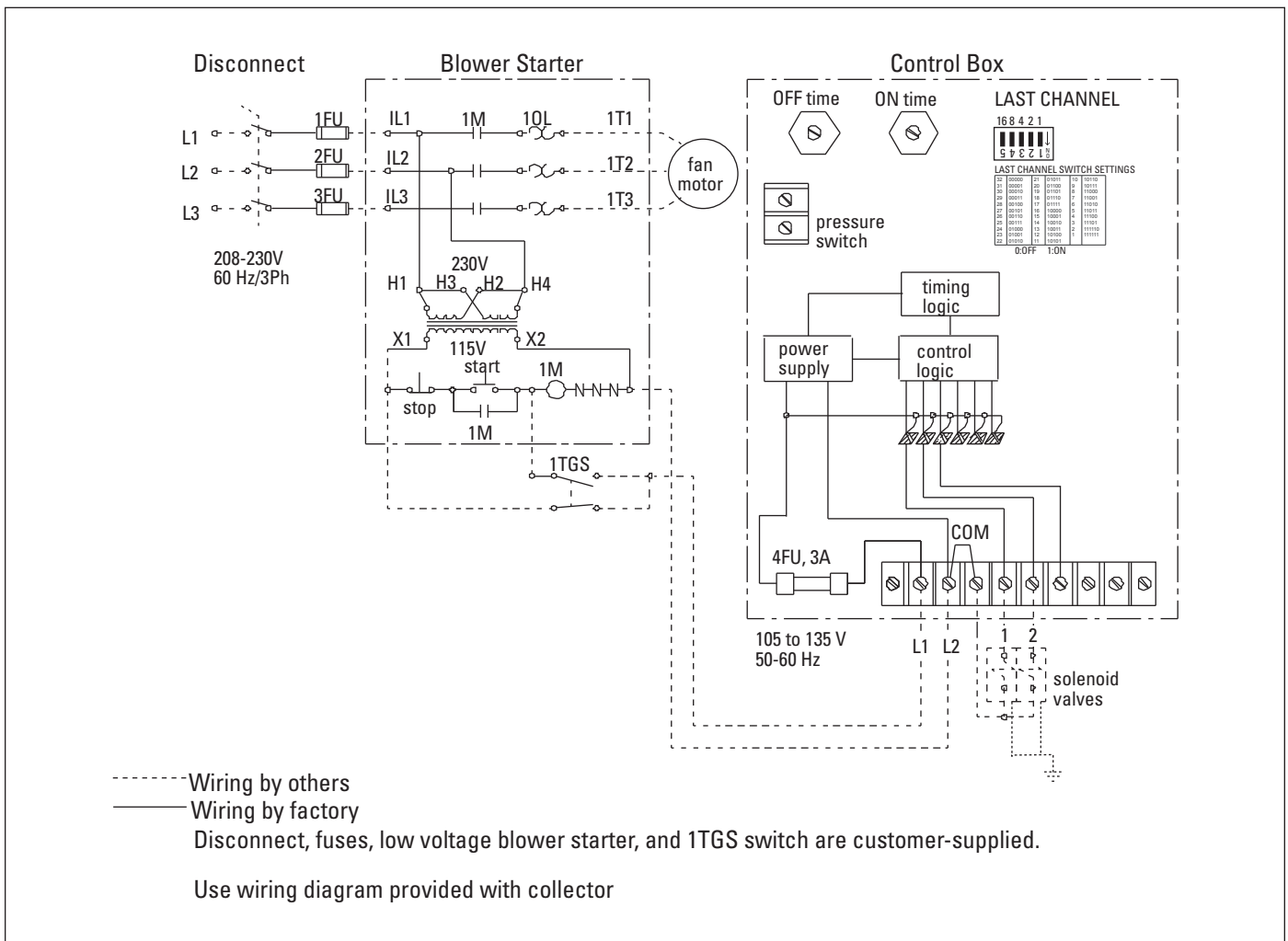

Solid-State Timer Typical Wiring Diagram

Preliminary Start-Up Check

Instruct all personnel on safe use and maintenance procedures.

WARNING

Electrical work during installation, service or maintenance must be performed by a qualified electrician and comply with all applicable national and local codes.

Turn power off and lock out electrical power sources before performing service or maintenance work.

Turn compressed air supply OFF, bleed and lock out lines before performing service or maintenance work.

Check that the collector is clear and free of all debris before starting.

Do not install in classified hazardous atmospheres without an enclosure rated for the application.

Optional fans over 600 lbs must be independently supported.

1. Check all electrical connections for tightness and contact.
2. Check for proper rotation as noted on the fan and/or hopper discharge device housing.

To reverse rotation, single-phase power supply:
Follow manufacturer's instructions on the motor's nameplate.

To reverse rotation, three-phase power supply:
Switch any two leads on the motor junction box.

WARNING

Do not interchange a power lead with the ground wire. Severe personal injury and/or property damage may result.

3. All access panels should be sealed and secure.
4. Check that the dust container is properly sealed and clamped.

5. Check that fan exhaust damper is set to the fully-closed position.
6. Check and remove all loose items in or near the inlet and outlet of the collector.
7. Check that all remote controls and solenoid enclosures (if applicable) are properly wired and all service switches are in the OFF position.
8. Check that all optional accessories are installed properly and secured.
9. Turn power ON at source.
10. Turn the compressed-air supply ON. Adjust pressure regulator for 90-psig.
11. Turn fan motor ON.

WARNING

Do not look into fan outlet to determine rotation. View the fan rotation through the back of the motor.

Check that the exhaust plenum is free of tools or debris before checking blower/fan rotation.

Stand clear of exhaust to avoid personal injury.

12. Adjust airflow with the exhaust damper.

NOTICE

Excess airflow can shorten filter life, cause electrical system failure and fan motor failure.

13. Turn powered hopper discharge devices ON.

Maintenance Information

Instruct all personnel on safe use and maintenance procedures.

WARNING

Use proper equipment and adopt all safety precautions needed for servicing equipment.

Electrical service or maintenance work must be performed by a qualified electrician and comply with all applicable national and local codes.

Turn power off and lock out electrical power sources before performing service or maintenance work.

Do not install in classified hazardous atmospheres without an enclosure rated for the application.

Turn compressed air supply OFF, bleed and lock out lines before performing service or maintenance work..

NOTICE

Do not set compressed-air pressure above 90-psig as component damage can occur.

All compressed air components must be sized to meet the maximum system requirements of 90-psig supply pressure.

The compressed-air supply must be oil and moisture free. Contamination in the compressed air used to clean filters will result in poor cleaning, cleaning valve failure, or poor collector performance.

Purge compressed air lines to remove debris before connecting to the collector's compressed air manifold.

Operational Checklist

1. Monitor the physical condition of the collector and repair or replace any damaged components.
Routine inspections will minimize downtime and maintain optimum system performance. This is particularly important on continuous-duty applications.
2. Periodically check the compressed air components and replace compressed air filters.

Drain moisture following the manufacturer's instructions. With the compressed air supply ON, check the cleaning valves, solenoid valves, and tubing for leaks. Replace as necessary.

3. Monitor pressure drop across filters.

Abnormal changes in pressure drop may indicate a change in operating conditions and possibly a fault to be corrected. For example, prolonged lack of compressed air will cause an excess build-up of dust on the filters resulting in increased pressure drop. Cleaning off-line with no flow usually restores the filters to normal pressure drop.

4. Monitor exhaust.
5. Monitor dust disposal.

Filter Removal and Installation

WARNING

Use proper safety and protective equipment when removing contaminants and filters.

Dirty filters may be heavier than they appear.

Use care when removing filters to avoid personal injury and/or property damage.

Turn power off and lock out electrical power sources before performing service or maintenance work.

Turn compressed air supply OFF, bleed and lock out lines before performing service or maintenance work.

CAUTION

Use care with any power assisted tools to avoid personal injury and/or property damage from rotating parts.

Do not operate with missing or damaged filters.

Filter Removal

1. Turn off power to the collector.
2. Begin filter replacement at one of the top filter access ports. Continue by replacing the remaining filters in the top row. Proceed to replace filters in the next rows.

Replacing filters row by row starting at the top will help limit dusting during replacement.

3. Remove access cover by turning knob counterclockwise.

WARNING

Do not use the access cover features as climbing equipment.

Use safe practices for maintenance and installation.

Do not drop filters

4. Break the seal between the filter cartridge and the sealing surface.
5. Slide each filter out the access port along the suspension yoke and dispose of properly.
6. Inspect and clean the sealing surface if necessary.

NOTICE

Clean dust from gasket sealing area to ensure a positive filter gasket seal.

7. Clean any dust from the yoke threads that may have accumulated during the filter removal.
8. Check for any accumulation of dust in the storage area and remove as necessary.

Filter Installation

1. Slide the gasket end of each new filter onto the end of the suspension yoke.

NOTICE

The filter shape and yoke work together to ensure proper filter alignment during filter installation. To assist with alignment, an alignment mark (\triangle) at the top of the filter endcap (non-gasketed end) must match with the alignment mark (∇) at the top of the filter access opening.

2. Inspect cover gaskets. Clean and/or replace as necessary.

3. After new filters have been installed, place the access cover on the yoke and hold it in position while tightening the knob securely by hand (3 turns) before using tool assist option.

If knob fails to thread onto yoke, on the opposite side of the hinge, apply slight pressure to the access cover using other hand. Continue to turn knob to start threading onto the yoke.

NOTICE

The access cover must be properly aligned to ensure a dust tight seal to the housing.

Do not exceed 150 in-lbs torque when securing the access cover as over tightening may cause damage to the filter and/or equipment.

When filter installation is complete, check to ensure that each access covers is seated and sealed against the filter housing to ensure a dust tight housing seal.

Dust Disposal

1. Empty dust container(s) as necessary to minimize dust in the hopper.
2. If the optional 55-gallon drum attachment is used, empty when drum is 2/3 full.
3. If optional slide gate is used, close gate before servicing drum.

CAUTION

Sharp edge of slide gate may result in personal injury while closing the slide gate. Keep hands clear when operating the slide gate.

4. Check integrity of gasket under drum cover.
5. Reinstall drum and open gate (if applicable).

Compressed Air Components

1. Periodically check the compressed air components and replace damaged or worn components as necessary.
2. Drain moisture following the manufacturer's instructions.
3. With the compressed-air supply ON, check the cleaning valves, solenoid valves, and tubing for leaks. Repair or replace as necessary.

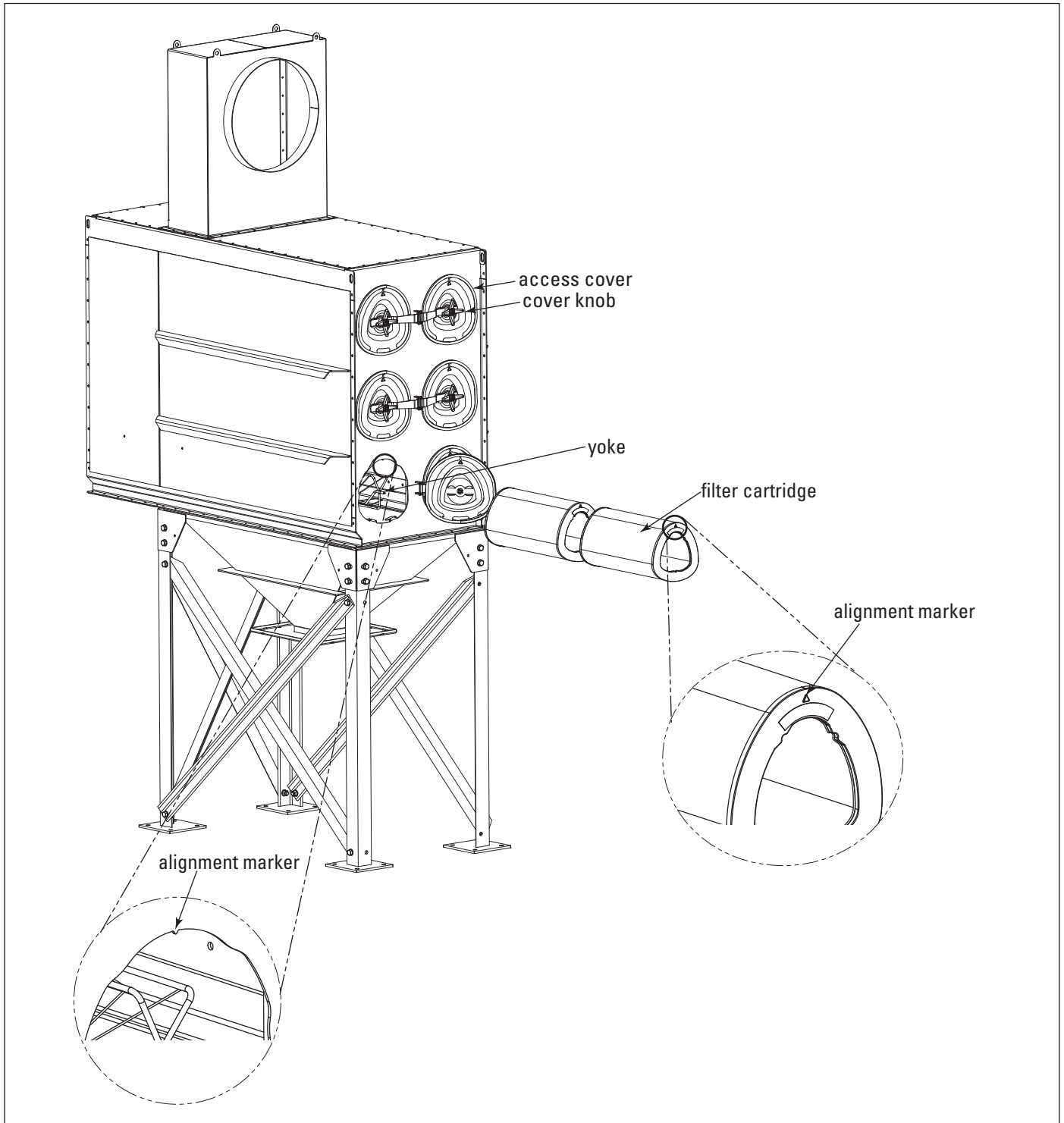

Filter Removal and Installation

Optional Equipment

Fan Blower

WARNING

Failure to lift the fan correctly can result in severe personal injury and/or property damage.

Use appropriate lifting equipment and adopt all safety precautions needed for moving and handling the fan.

A crane or forklift is recommended for unloading, assembly, and installation of the fan.

Location must be clear of all obstructions, such as utility lines or roof overhang.

CAUTION

To avoid personal injury and/or damage to equipment, ensure fan blowers are properly attached to equipment.

NOTICE

The use of a damper or variable fan drive (VFD) is required to control airflow through the collector. Lack of a control damper or VFD will shorten filter life.

The collector can accept two types of direct mounted Donaldson fan blowers, Torit Backward Inclined (TBI) or Torit Radial Blade (TRB), to the top or side of the collector.

For complete information, see the most current version of the TBI or TRB Fan Installation, Operation and Maintenance manuals.

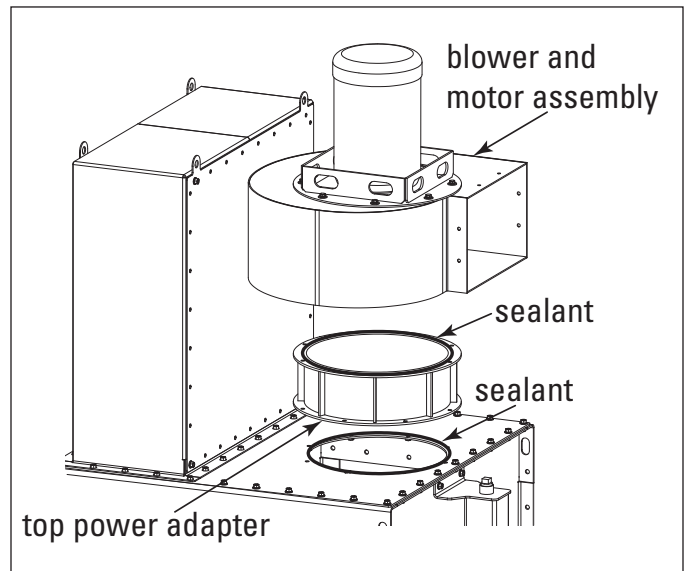

Top Mount Fan Blower Field Installation

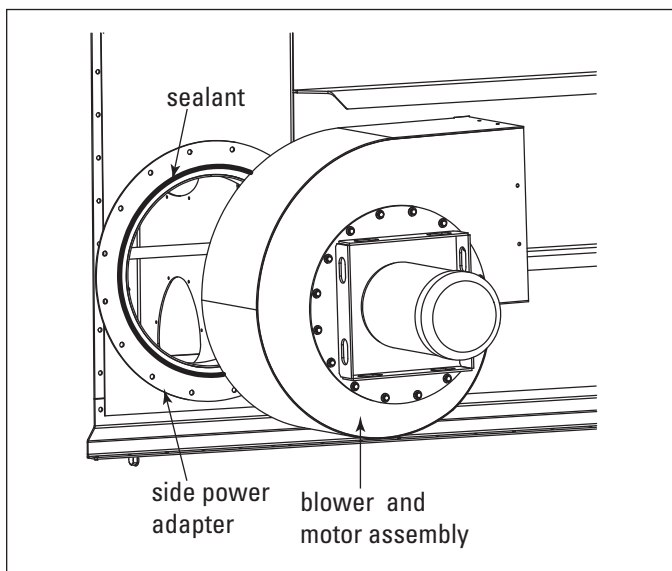

Side-Mount Fan Blower Field Installation

TBI and TRB Style Damper and Silencer Support Bracket

Loosely assemble the silencer's support brackets from silencer pack following procedure on the silencer pack drawings.

Side mount silencer support brackets will require modification in the field.

- a. Align the support bracket to the underside of the silencer, flush with the cabinet wall and mark the drill locations and support lengths.
- b. Drill pilot holes with a 0.339-in bit.
- c. Secure brackets using 3/8-in thread-forming bolts.

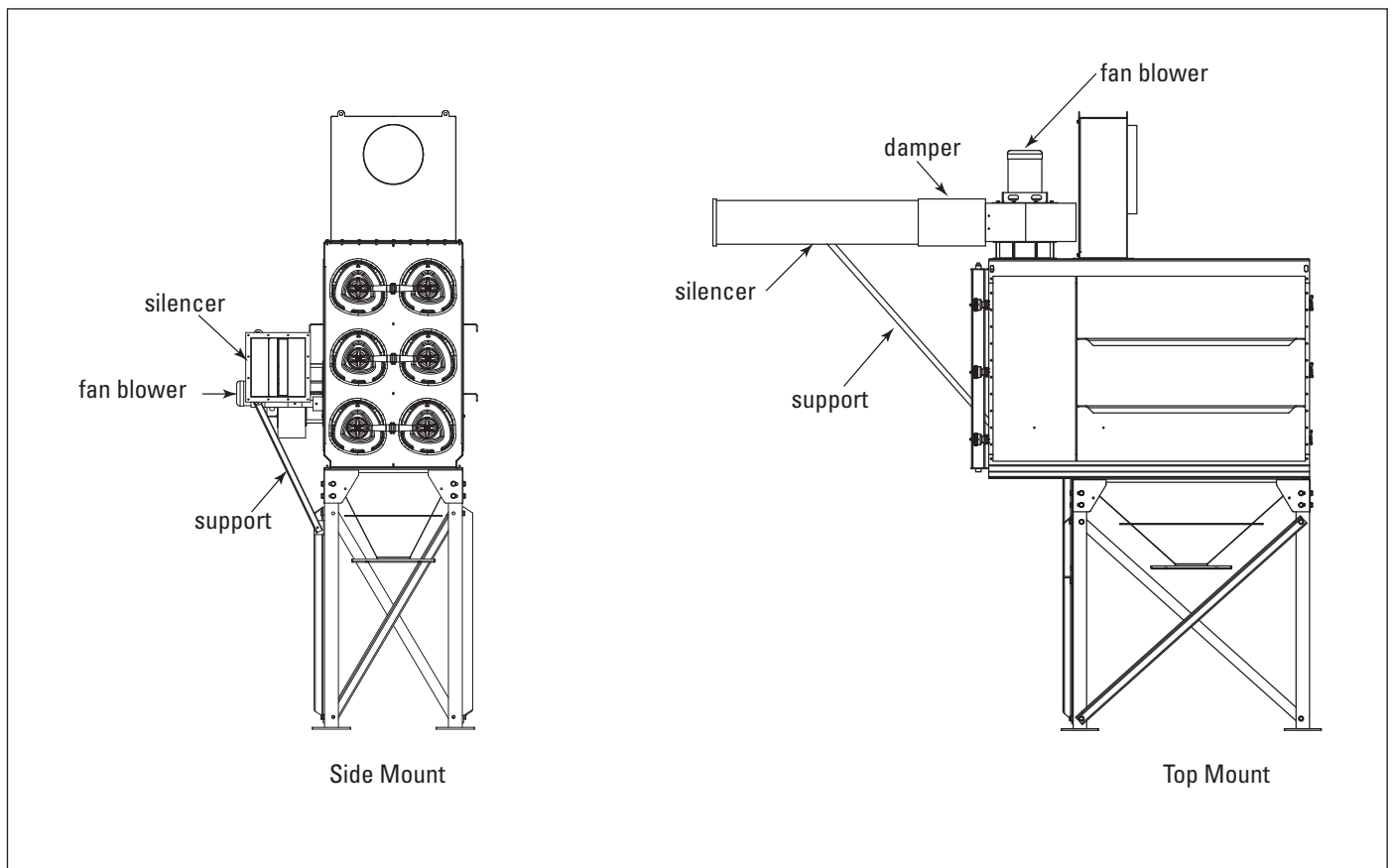

Side and Top-Mount Damper and Silencer Support Bracket

Hopper Access

WARNING

Completely turn off and lock out all dust collector and ancillary equipment before removing hopper access cover.

Use caution when removing hopper access cover to avoid personal injury and/or property damage.

Use appropriate care when accessing the inside of the hopper.

55-Gallon Drum Pack

The drum pack is designed to fit a customer-supplied, standard 55-gallon drum and provides easy access for dust removal and disposal. A flexible hose connects the drum cover to the hopper. Placing a pallet under the drum allows heavier materials to be moved quickly using a forklift or pallet jack. If a pallet is used, the length of flexible hose may need to be shortened.

CAUTION

Sharp edge of slide gate may result in personal injury while closing the slide gate. Keep hands clear when operating the slide gate.

With Slide Gate

1. Place the 1/8-in gasket spacer between the hopper flange and slide gate as shown.
2. Attach the drum pack and slide gate to the hopper flange using 3/8-16 bolts, washers, and hex nuts.
3. Attach the drum cover to the 55-gallon drum.
4. Use latches to secure the cover to the drum, if equipped.
5. Connect the flexible hose between the drum cover and slide gate. Secure with hose clamps.

Without Slide Gate

1. Place 1/4-in diameter rope-type sealant between the hopper flange and the drum cover mounting flange toward the inside edge of the bolt pattern.
2. Fasten using the bolts, washers, and nuts supplied.
3. Attach the drum cover to the 55-gallon drum.
4. Use latches to secure the cover to the drum, if equipped.
5. Connect the flexible hose between the drum cover and the adapter. Secure with hose clamps.

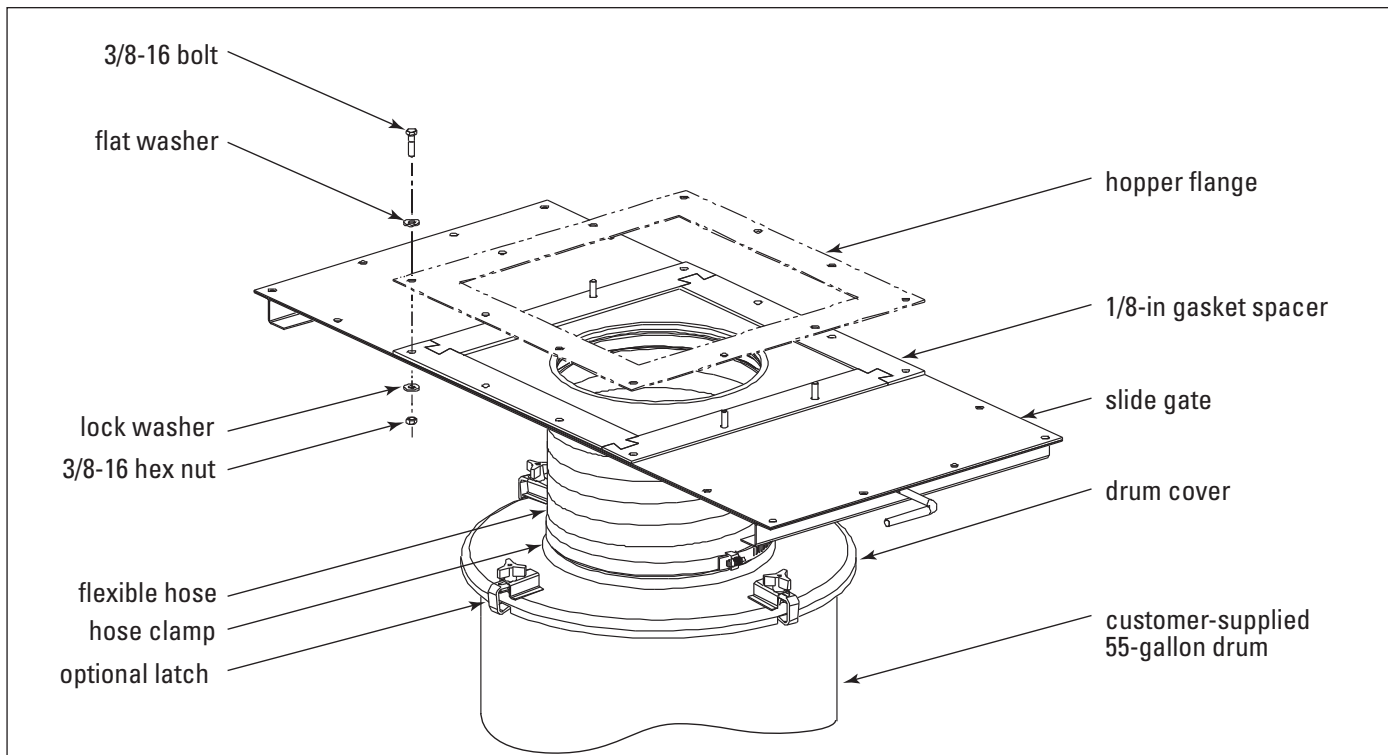

55-Gallon Drum Pack with Slide Gate

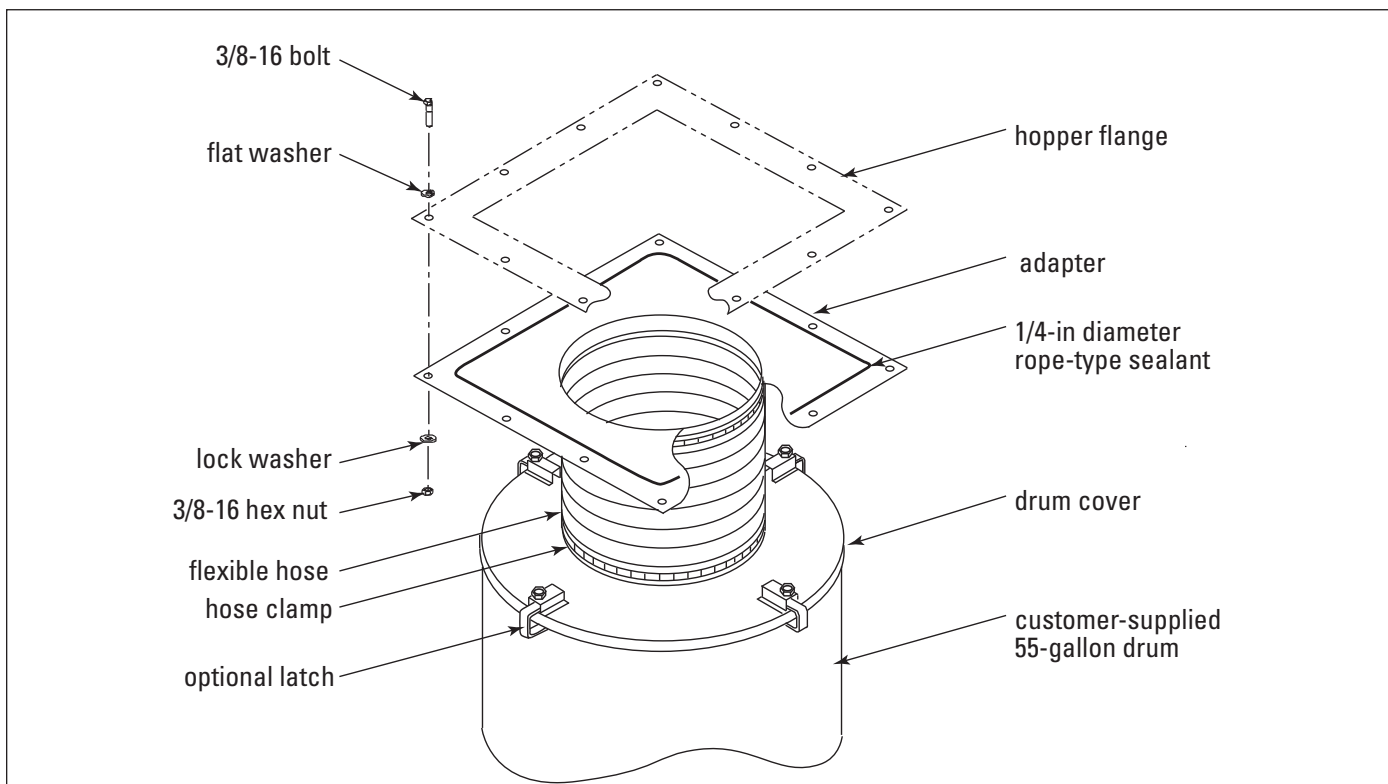

55-Gallon Drum Pack without Slide Gate

Rotary Valve and Transition

⚠ DANGER

Rotating blades can cause serious injury.

Turn power off and lock out electrical source before performing service or maintenance work.

Keep hands, feet and loose clothing away from both inlet and outlet openings to avoid injury or damage when valve is operating.

NOTICE

Customer supplied discharge devices which exceed a weight of 800 lbs must be independently supported.

Rotary Valves are used to maintain a seal on the hopper outlet while material is discharged from the hopper. A transition allows a valve to be connected to the hopper discharge when there is a size difference between the hopper and the valve.

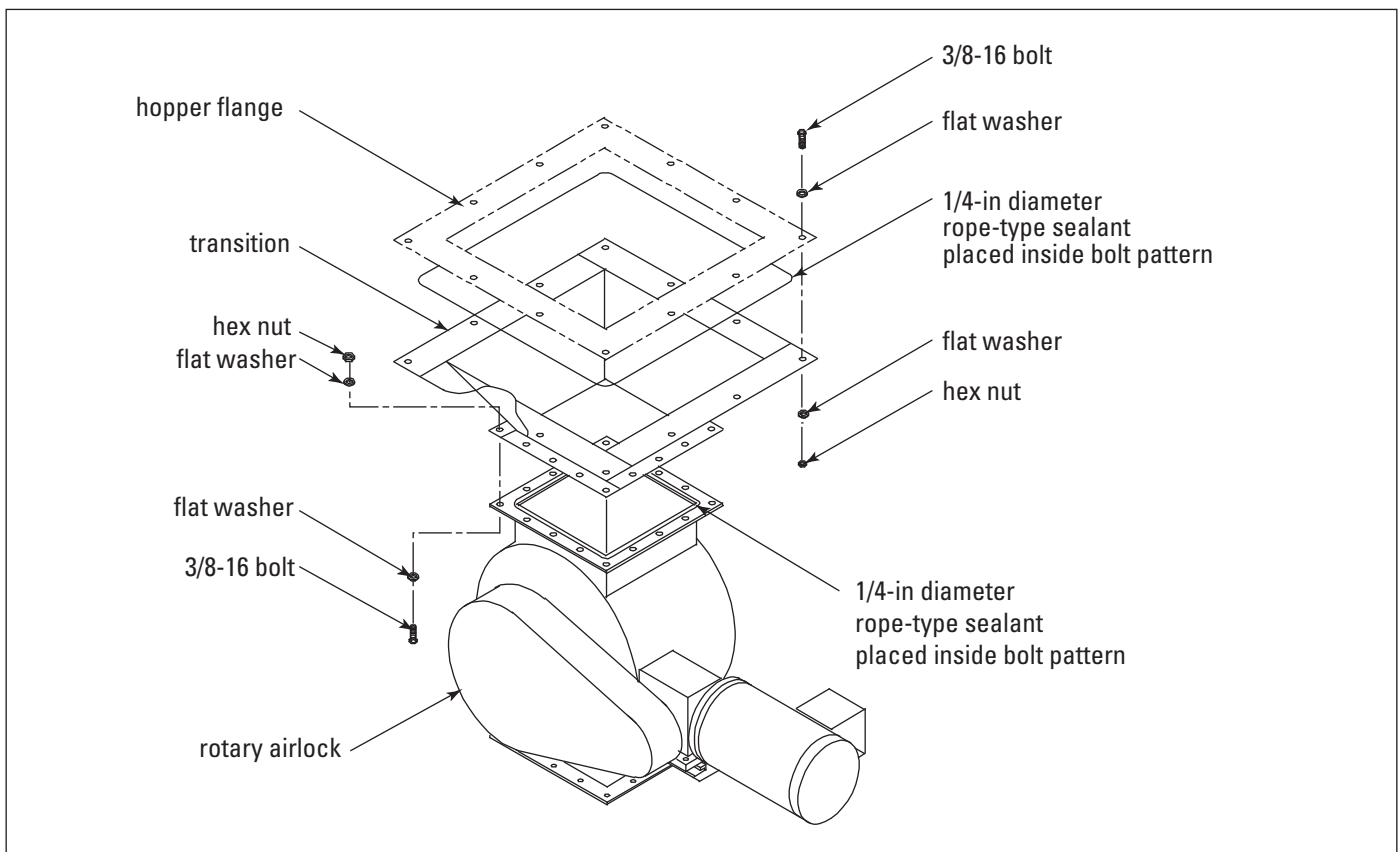

Rotary Valve and Transition

Magnehelic® Gauge

The Magnehelic is a differential pressure gauge used to measure the pressure difference between the clean-air and dirty-air plenums and provides a visual display of filter change requirements. The high-pressure tap is located in the dirty-air plenum and the low-pressure tap is located in the clean-air plenum.

1. Choose a convenient, accessible location on or near the collector for mounting that provides the best visual advantage.
2. Plug the pressure ports on the back of the gauge using two, 1/8-in NPT pipe plugs supplied. Install two, 1/8-in NPT male adapters supplied with the gauge into the high- and low-pressure ports on the side of the gauges.
3. Attach the mounting bracket using three, #6-32 x 1/4-in screws supplied.
4. Mount the gauge and bracket assembly to the supporting structure using two, self-drilling screws.
5. Thirty-five feet of plastic tubing is supplied and must be cut in two sections. Connect one section of tubing from the gauge's high-pressure port to the pressure fitting located in the dirty-air plenum. Connect remaining tubing from the gauge's low-pressure port to the fitting in the clean-air plenum. Additional tubing can be ordered from your representative.
6. Zero and maintain the gauge as directed in the manufacturer's Operating and Maintenance Instructions provided.

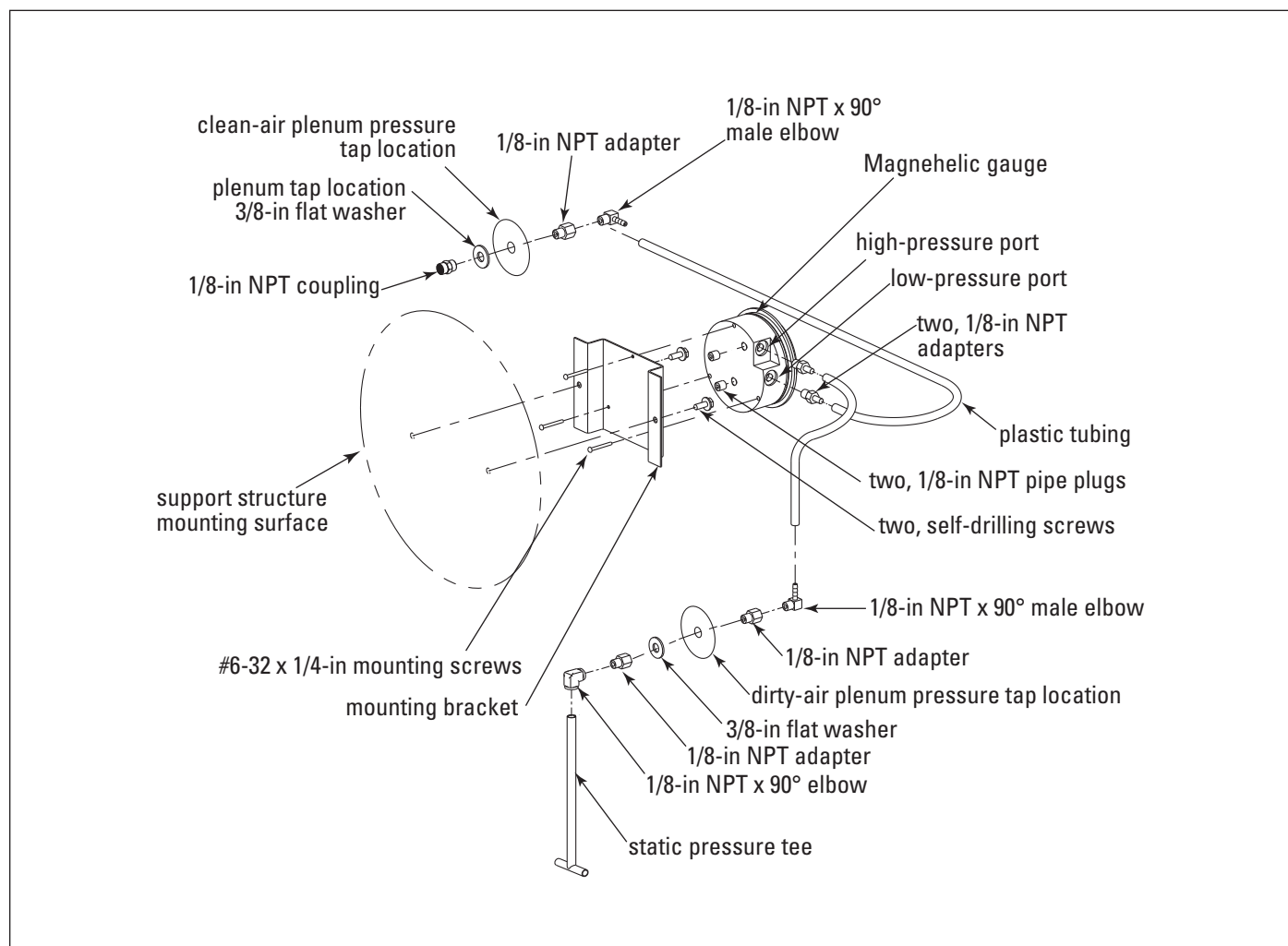

Magnehelic Gauge Installation

Photohelic® Gauge

⚠ WARNING

Electrical installation, service, or maintenance work must be performed by a qualified electrician and comply with all applicable national and local codes.

Turn power off and lock out electrical power sources before performing service or maintenance work.

Do not install in classified hazardous atmospheres without an enclosure rated for the application.

The Photohelic combines the functions of a differential pressure gauge and a pressure-based switch. The gauge function measures the pressure difference between the clean-air and dirty-air plenums and provides a visual display of filter condition. The high-pressure tap is located in the dirty-air plenum and a low-pressure tap is located in the clean-air plenum. The pressure-based switch function provides high-pressure ON and low-pressure OFF control of the filter cleaning system.

1. Choose a convenient, accessible location on or near the collector for mounting that provides the best visual advantage.

2. Mount the gauge to the remote panel or door using the mounting ring, retaining ring, and four #6-32 x 1 1/4-in screws. Do not tighten screws. Connect two, 1/8-in NPT x 1/4-in OD male adapters to the gauge's high- and low-pressure ports. Tighten screws.
3. On the back of the gauge, remove four #6-32 x 5/16-in screws and plastic enclosure. Set aside. Add two jumper wires supplied by customer. Remove the jumper from the pressure switch located on the timer board, if equipped. Using the 3/4-in conduit opening, wire the gauge as shown. Reassemble and fasten enclosure securely.
4. Thirty-five feet of plastic tubing is supplied and must be cut in two sections. Connect one section of tubing from the gauge's high-pressure port to the pressure fitting located in the dirty-air plenum. Connect remaining tubing from the gauge's low-pressure port to the fitting in the clean-air plenum. Additional tubing can be ordered from your representative.
5. Zero and maintain the gauge as directed in the manufacturer's Operating and Maintenance Instructions provided.
6. To install the Photohelic Gauge mounted in a NEMA 4, Weatherproof Enclosure, follow Steps 4 and 5.

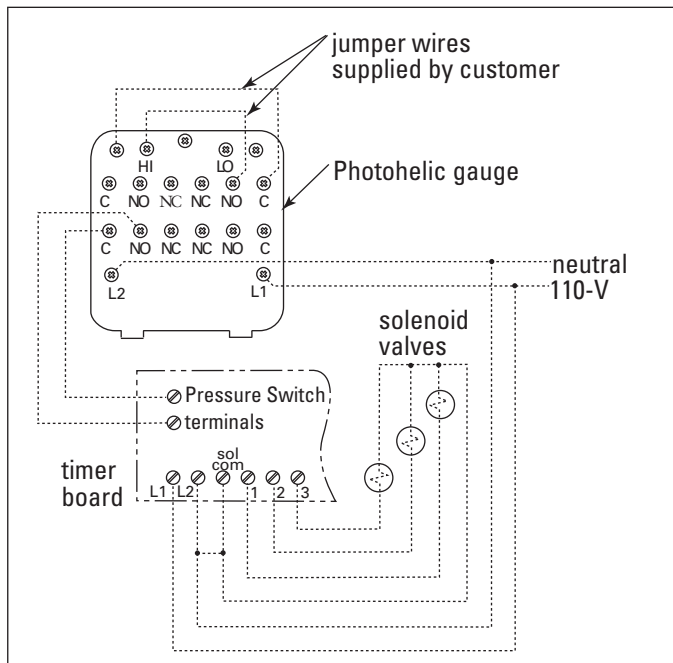

Photohelic Gauge Wiring Diagram

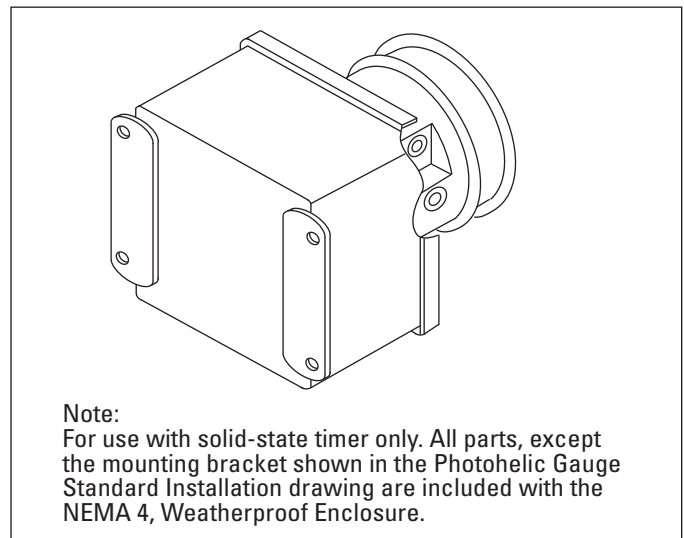

Note:
For use with solid-state timer only. All parts, except the mounting bracket shown in the Photohelic Gauge Standard Installation drawing are included with the NEMA 4, Weatherproof Enclosure.

Photohelic Gauge in Optional NEMA 4 Weatherproof Enclosure

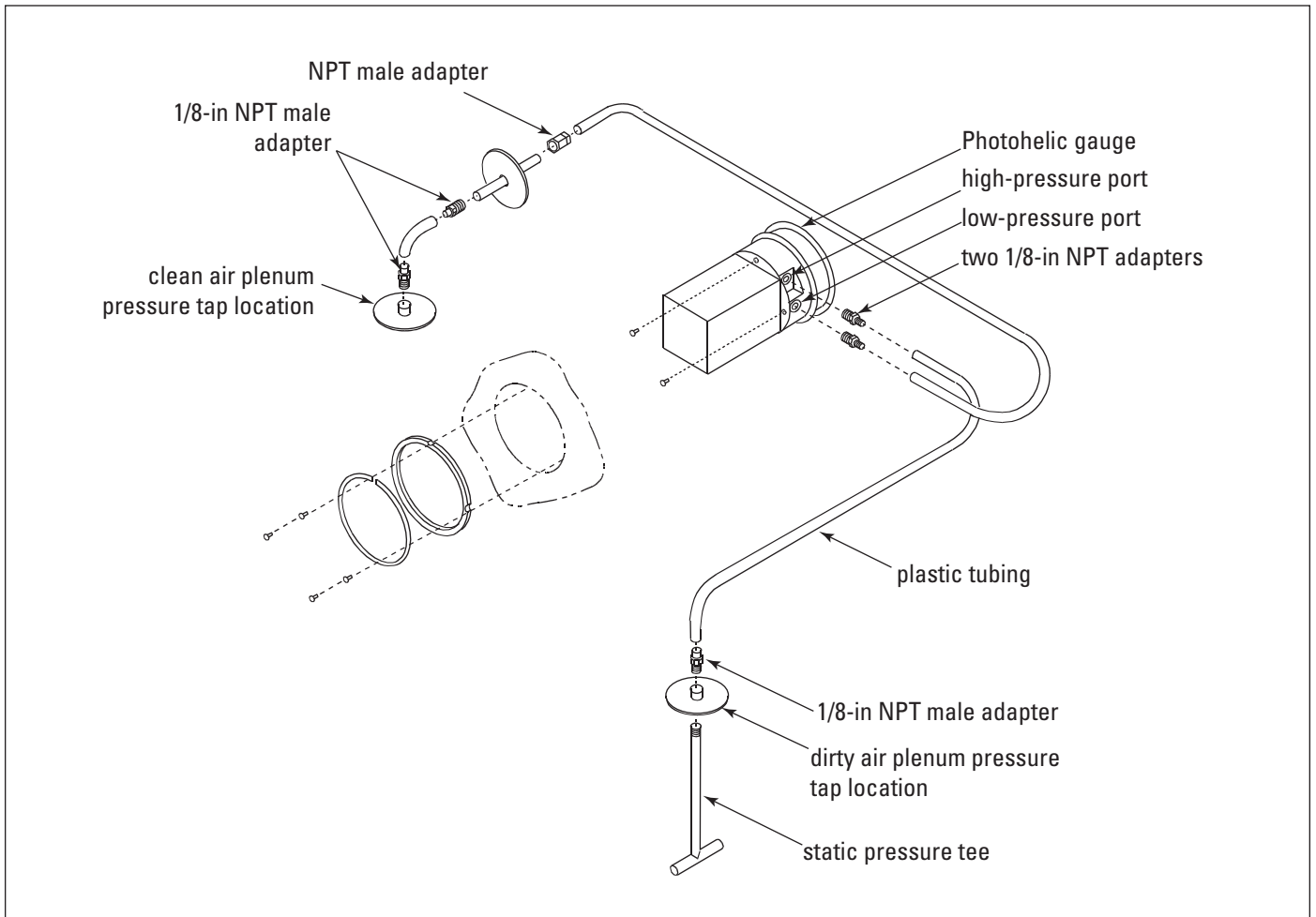

Photohelic Gauge, Remote Panel or Door Installation

Delta P Control

For complete information, see the most current version of the Delta P Installation, Operation, and Maintenance manual.

Description

The Delta P Controller monitors the differential pressure between the clean-air and dirty-air plenums, providing a visual display of the filter condition. When combined with a pulse timer, it manages the pressure drop by turning the cleaning mechanism On and Off at the chosen limits. There are three (3) set points: High Pressure On, Low Pressure Off, and Alarm. The first two, High Pressure On and Low Pressure Off, control the filter cleaning system. The third, Alarm, provides a relay output to activate an external alarm supplied by others.

Operation

Normal

The Delta P Controller monitors the pressure in the clean-air and dirty-air air plenums while the collector is running. The blower draws air through the filters, creating a pressure drop. The Delta P Controller measures the pressure drop and provides a visual display in inches water gauge or metric (SI) collectors of daPa.

Filter Cleaning

When the pressure drop across the filters reaches the High Pressure On setpoint, the controller closes an output relay allowing a timer to trigger the cleaning valves sequentially. When the controller senses that the pressure drop has decreased to the Low Pressure Off setpoint, the relay opens and the cleaning cycle stops. This sequence continues as long as the collector is in use, maintaining the pressure drop within a narrow range.

Alarm

The Alarm setpoint is set to a higher setting than the High Pressure On setpoint used to start the filter cleaning cycle. It indicates situations when the cleaning system cannot reduce the pressure drop due to cleaning system failure, lack of compressed air, or the end of the filter's useful life. There is a time delay prior to setting the Alarm to prevent nuisance trips. The Delta P Controller also provides an input connection for a remote alarm reset.



Delta P Control Display

Delta P Plus Control

For complete information, see the most current version of the Delta P Plus Installation, Operation, and Maintenance manual.

Description

The Delta P Plus Controller monitors the differential pressure between the clean-air and dirty-air plenums, providing a visual display of the filter condition. When combined with a pulse timer, it manages the pressure drop by turning the cleaning mechanism On and Off at the chosen limits. There are three (3) set points: High Pressure On, Low Pressure Off, and Alarm. The first two, High Pressure On and Low Pressure Off, control the filter cleaning system. The third, Alarm, provides a relay output to activate an external alarm supplied by others.

The user can program the Delta P Plus Controller to pulse while the collector is running, to maintain a relatively constant pressure drop across the filters, pulse only after the collector is shut down (after-shift cleaning), or a combination of both, cleaning while running as well as end of the shift.

Operation

Normal

The Delta P Plus Controller monitors the pressure on both sides of the tubesheet while the collector is running. As air flows through the filters, the resistance of the media and collected dust creates a pressure difference or "drop" between the dirty and clean air plenums. The Delta P Plus Controller measures the pressure drop and provides a visual display in inches water gauge or metric (SI) collectors of daPa.

Filter Cleaning

The Delta P Plus Controller offers three filter cleaning options.

1. **Differential Pressure Cleaning (DFF)** - When the pressure drop across the filters reaches the Controller's High Pressure On setpoint, the Controller closes an output relay allowing a sequential timer to trigger the cleaning valves. When the Controller senses that the pressure drop has decreased to the Low Pressure Off setpoint, the relay opens and the cleaning cycle stops. This sequence continues as long as the collector is in use, maintaining the

pressure drop within a narrow range.

2. **Downtime Cleaning (DTC)** - The Delta P Plus Controller monitors the collection system. When the pressure drop exceeds the Low Pressure Off set point and then approaches zero again, the Delta P Plus Controller runs a delay timer to allow the blower to come to a stop and then engages the cleaning mechanism for a preselected time.
3. **Combined Differential and Downtime Cleaning (ALL)** - The Delta P Plus Controller combines the two functions described above; maintaining the pressure drop in a narrow band and downtime cleaning the filters when the collector is shut down. The downtime cleaning function can be toggled On or Off from the keyboard.

Alarm

The Alarm setpoint is set to a higher setting than the High Pressure On used to start the filter cleaning cycle. It indicates situations when the cleaning system cannot reduce the pressure drop due to cleaning system failure, lack of compressed air, or the end of the filter's useful life. There is a time delay prior to setting the Alarm to prevent nuisance trips. The Delta P Plus Controller also provides an input connection for a remote Alarm reset.



Delta P Plus Control Display

Delta P C-01 Control

The Torit Delta P C-01 Controller monitors the differential pressure between the clean and dirty air plenums, providing a visual display of the filter condition. It controls the pressure drop by turning the cleaning mechanism On and Off at the chosen limits. There are three (3) set points: High Pressure On, Low Pressure Off, and Alarm. The first two, High Pressure On and Low Pressure Off, control the filter cleaning system. The third, Alarm, provides a relay output to activate an external alarm supplied by others.

The user can program the Delta P C-01 to pulse while the collector is running to maintain a relatively constant pressure drop across the filters, pulse only after the collector is shut down (after-shift cleaning), or a combination of both, cleaning while running as well as end of shift.

For complete information, see the most current version of the Delta P C-01 Installation, Operation, and Maintenance manual.

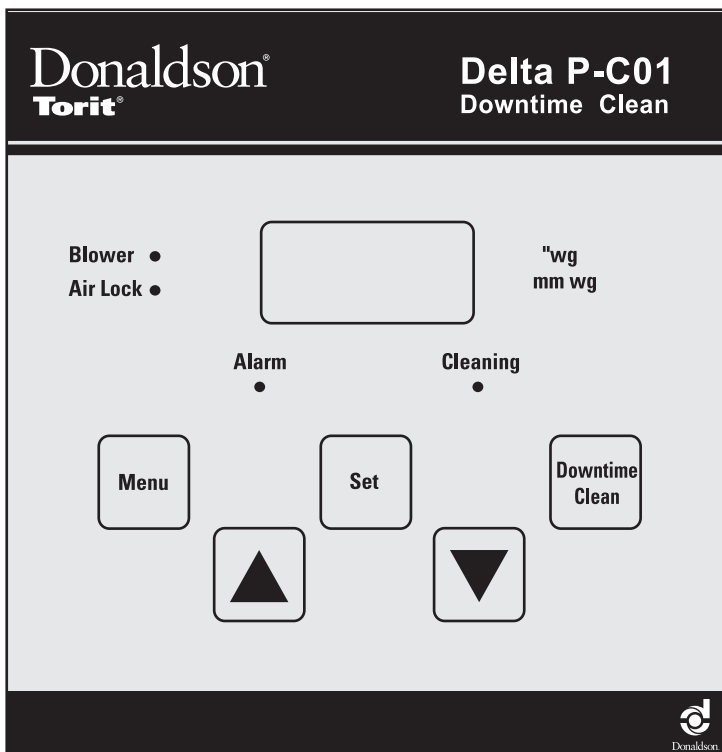

Delta P-01 Control Display

Inlet Plenum

The inlet plenum is standard on Downflo Evolution collectors unless another inlet plenum option has been selected.

The inlet plenum directs the dirty air stream to the back of the dirty-air plenum over the venturi section.

1. Remove the unit's shipping cover plate. Remove excess sealant from opening.
2. Apply 1/4-in sealant around the opening toward the inside edge of the bolt pattern.
3. Align the holes on the inlet collar with the holes in the unit and secure using 3/8-16 x 1-in bolts and flat washers supplied.

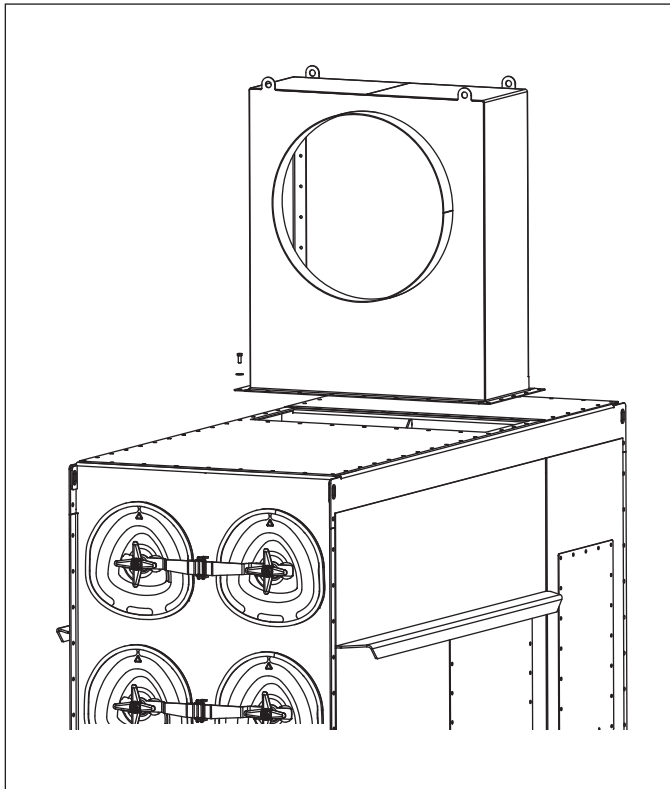

Inlet Plenum

High Flow Inlet Plenum

The high flow inlet plenum is used in applications with higher flow rates.

The high flow inlet plenum is supplied with standard service access panels on the front, back and top of the plenum

The top access panel is available with and without an explosion vent.

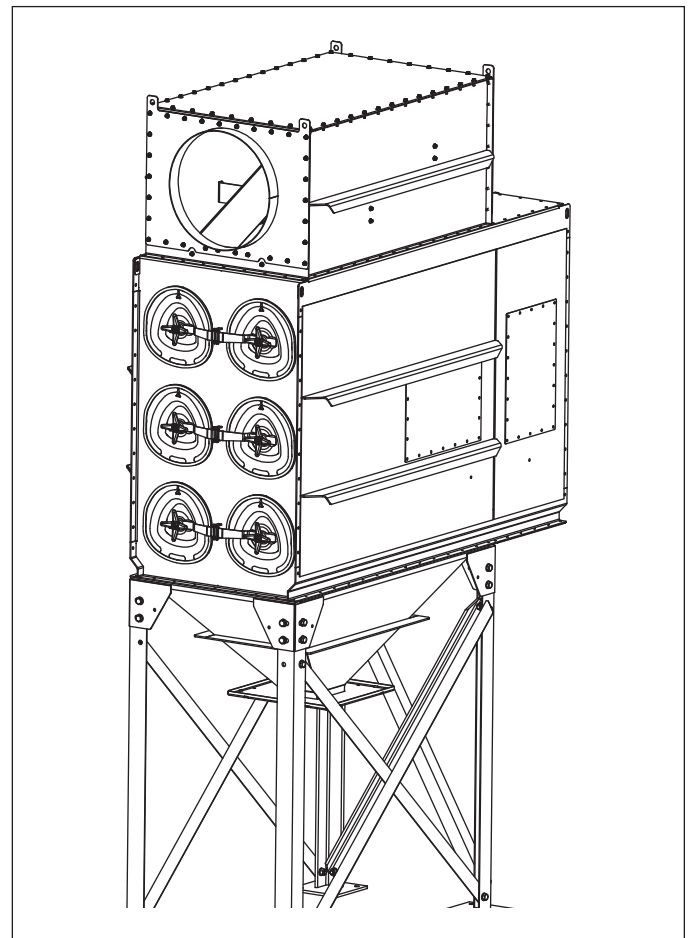

High Flow Inlet Plenum

Extended Dirty-Air Plenum

The extended dirty-air plenum is used in applications requiring an air management module or when a single inlet serves multiple modules.

The extended dirty-air plenum is supplied with standard service access panels on the sides and top of the plenum.

The top access panel is available with and without an explosion vent.

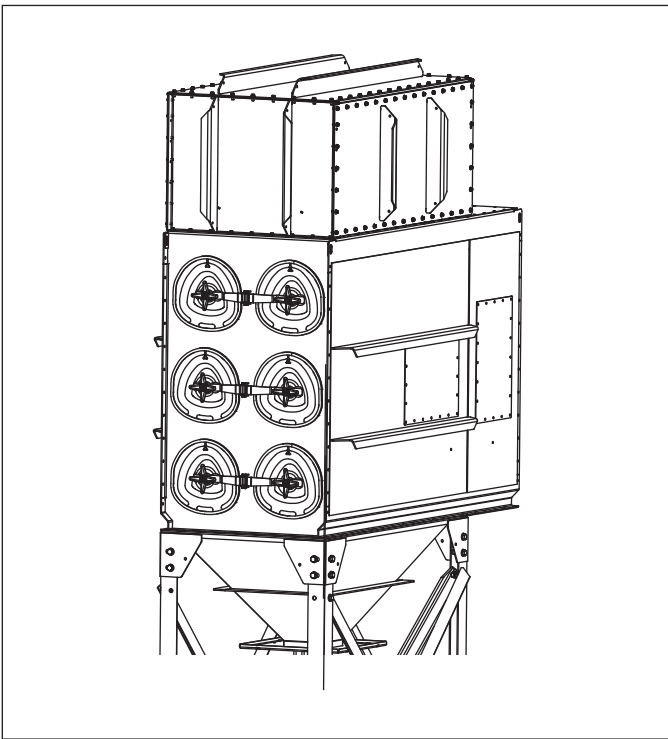

Extended Dirty-Air Plenum

Air Management Module

The air management module is used in applications involving heavy grain loading, large or abrasive particles in the airstream, or in applications when a collector with a single inlet serves multiple modules. It is equipped with a louvered panel near the bottom, which prevents re-entrainment of the dust that falls through to the hopper. This module does not contain filters, and is available for use with an extended dirty-air plenum only.

Air management modules are supplied with a standard 36 x 24-in and 36 x 16-in covered opening on front of the collector.

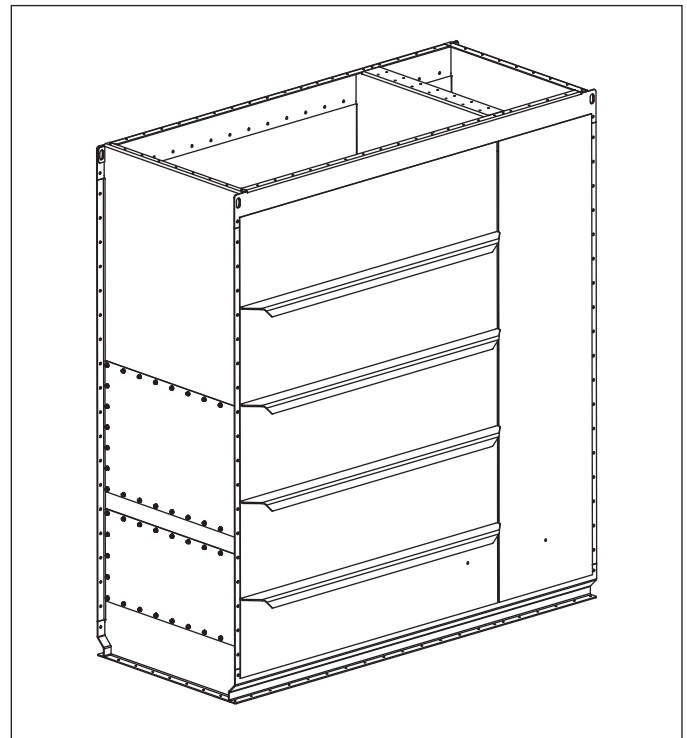

Air Management Module

Platforms and Ladders

Stationary platforms are available for each size collector.

For two filter wide models the platform is available for standard or steep-sided hoppers with the ladder located left, right, or front of the platform.

On three filter wide models the platform is available for standard hoppers only with ladder access on the left or right side only. Complete installation and assembly instructions are shipped with the platform.

CAUTION

Dropping the platform can result in personal injury and/or property damage. Secure the platform assembly to the crane or forklift with straps or clamps.

Stationary Platform

1. Pre-assemble the platform according to the instructions shipped with the platform. The hardware and placement is called out on the assembly drawing.
2. Lift the assembled platform into position and secure following the assembly drawing instructions.
3. Tighten all hardware before removing crane or forklift.
4. Check platform hardware each time the platform is used.

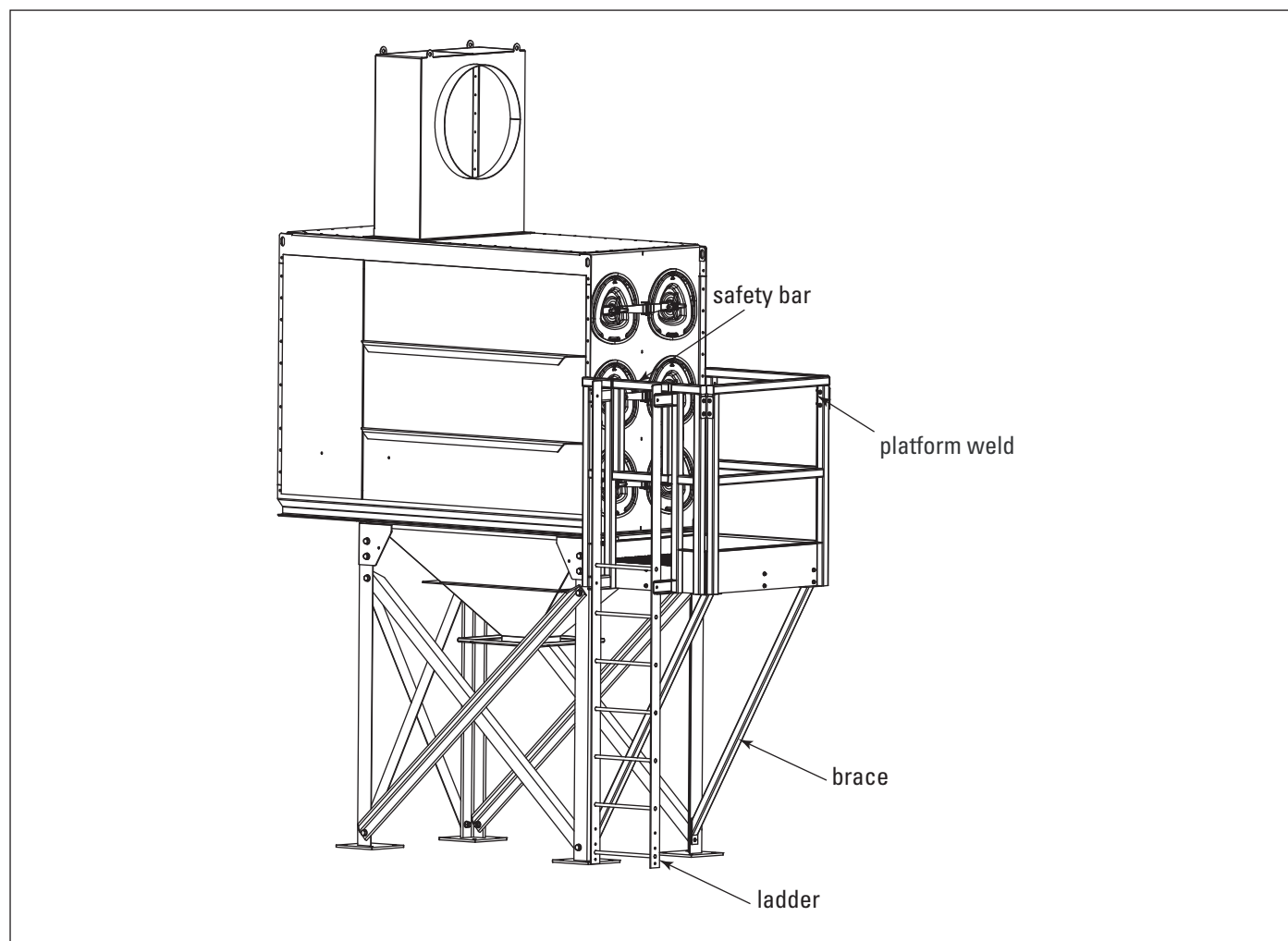

Stationary Platform

Cold Climate Kit

WARNING

Electrical installation, service, or maintenance work must

be performed by a qualified electrician and comply with all applicable national and local codes.

Turn power off and lock out electrical power sources before performing service or maintenance work.

Do not install in classified hazardous atmospheres without an enclosure rated for the application.

A cold climate kit provides heat to the pulse valves to prevent cold weather freeze up. The basic kit, for use in applications that have a moderate amount of moisture in the compressed-air supply, consists of a small heating element and thermostat installed in the solenoid enclosure. The basic kit is factory-installed and supplied with the appropriate solenoid wiring instructions.

A heavy-duty kit is available for applications that have moderate-to-high amounts of moisture in the compressed-air supply and consists of the basic kit plus a heat cable to deliver heat to the large pulse valves. This kit is customer-installed and detailed installation instructions are provided.

1. Install the power connection kit on the heat cable following the manufacturer's instructions.
2. Start with the upper right-hand valve, wrap heat cable around the valve as shown in Detail A. Pull heat cable tight.

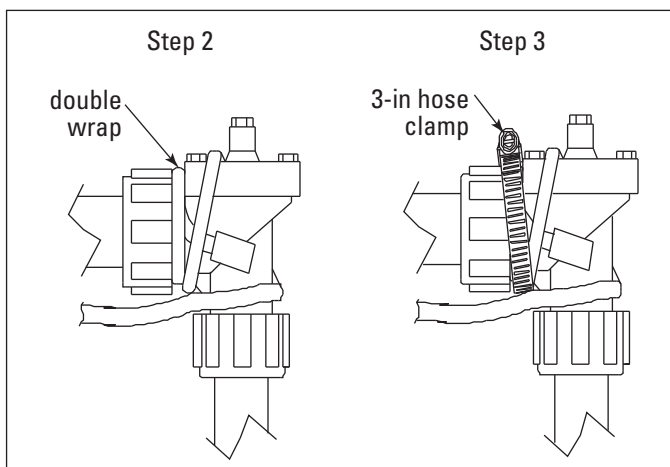

Cold Climate Kit, Detail A

NOTICE

Double wrap between round coupling and square valve cover.

3. Position a 3-in hose clamp around the double wrapped heat cable and tighten securely.
4. Wrap remaining valves using the same technique in the order shown in Detail B.
5. Drill a 1-in diameter hole in the back of the junction box. See Detail C. Assemble the power connection kit following the manufacturer's instructions.
6. Secure junction box to manifold using two, 8-in hose clamps wrapped around the standoff.
7. Wrap 6-ft of pipe insulation tape around each heat-cable wrapped valve. Wrap the entire valve, double wrapping the hose-clamped heat cable. Secure with cable ties.

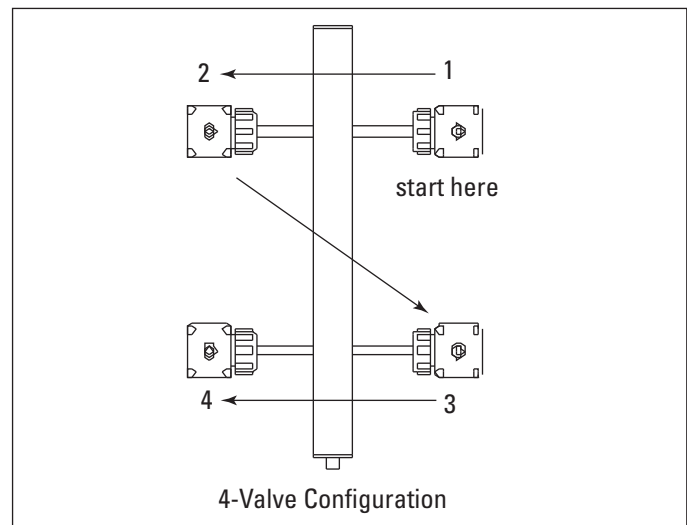

Cold Climate Kit, Detail B

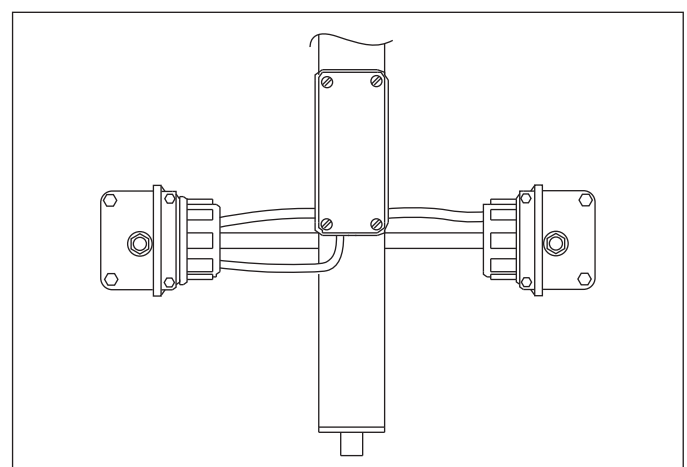

Cold Climate Kit, Detail C

Explosion Vent

WARNING

Personal injury, death, and/or property damage can result from material discharge during venting.

The material discharged during the venting of an explosion must be safely directed outdoors away from areas occupied by personnel to reduce risk of personal injury and/or property damage.

The risk of personal injury and/or property damage can be minimized or avoided by locating vented equipment outside buildings and away from normally occupied areas.

Explosion vents should be inspected regularly to confirm physical and operational condition. Replace any damaged parts immediately.

Standard explosion vents are intended for outdoor installations only.

NOTICE

Remove all shipping materials, including covers, from the explosion relief vents prior to installation. Failure to remove shipping covers will seriously compromise explosion vent operation.

Explosion venting calculations are based on formulas from NFPA-68 for outdoor applications only, with no duct or obstructions on the explosion vent panel.

Contact Donaldson Torit for assistance in calculating specific venting requirements for equipment.

Sprinkler

CAUTION

Sprinklers can place a large quantity of water in the dust collector when activated. Provide adequate drainage to remove water. Excess water weight can cause the leg structure to collapse.

Fire control sprinklers are available for models operating under negative pressure. Donaldson Torit supplied sprinklers require a minimum of 15-psig water pressure which will produce a discharge per sprinkler head of 17 gallons per minute.

NOTICE

Consult with local authorities when installing fire control systems on dust collection equipment.

1. Remove or open the filter access covers to access the sprinkler tap located in the dirty-air plenum.
2. Apply pipe sealant to the threads of the pipe reducer located on the sprinkler assembly.
3. Thread sprinkler assembly onto the 1-in diameter sprinkler tap.
4. Tighten securely.

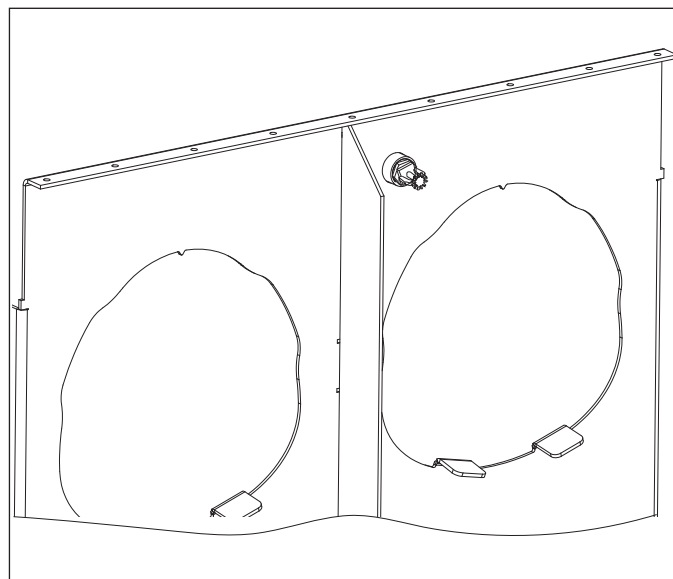

Sprinkler

Troubleshooting

Problem	Probable Cause	Remedy
Fan blower and motor do not start	Improper motor wire size	Rewire using the correct wire gauge as specified by national and local codes.
	Not wired correctly	Check and correct motor wiring for supply voltage. See motor manufacturer's wiring diagram. Follow wiring diagram and the National Electric Code.
	Collector not wired for available voltage	Correct wiring for proper supply voltage.
	Input circuit down	Check power supply to motor circuit on all leads.
	Electrical supply circuit down	Check power supply circuit for proper voltage. Check for fuse or circuit breaker fault. Replace as necessary.
Fan blower and motor start, but do not stay running	Incorrect motor starter installed	Check for proper motor starter and replace if necessary.
	Access doors are open or not closed tight	Close and tighten access doors. See Filter Installation.
	Hopper discharge open	Check that dust container is installed and properly sealed.
	Damper control not adjusted properly	Check airflow in duct. Adjust damper control until proper airflow is achieved and the blower motor's amp draw is within the manufacturer's rated amps.
	Electrical circuit overload	Check that the power supply circuit has sufficient power to run all equipment.
Clean-air outlet discharging dust	Filters not installed correctly	See Filter Installation.
	Filter damage, dents in the end caps, gasket damage, or holes in media	Replace filters as necessary. Use only genuine Donaldson replacement parts. See Filter Installation.
	Access cover(s) loose	Tighten access doors securely. See Filter Installation.
Insufficient airflow	Fan rotation backwards	Proper fan rotation is clockwise from the top of the collector. The fan can be viewed through the back of the motor. See Preliminary Start-Up Check.
	Access doors open or not closed tight	Check that all access doors are in place and secured. Check that the hopper discharge opening is sealed and that dust container is installed correctly.
	Fan exhaust area restricted	Check fan exhaust area for obstructions. Remove material or debris. Adjust damper flow control.
	Filters need replacement	Remove and replace using genuine Donaldson replacement filters. See Filter Removal and Installation.
	Lack of compressed air	See Rating and Specification Information for compressed air supply requirements.

Troubleshooting

Problem	Probable Cause	Remedy
Insufficient airflow continued	Lack of compressed air	See Rating and Specification Information for compressed air supply requirements.
	Pulse cleaning not energized	Use a voltmeter to check the solenoid valves in the control panel. Check pneumatic lines for kinks or obstructions.
	Dust storage area overfilled or plugged	Clean out dust storage area. See Dust Disposal.
	Pulse valves leaking compressed air	Lock out all electrical power to the collector and bleed the compressed air supply. Check for debris, valve wear, pneumatic tubing fault, or diaphragm failure by removing the diaphragm cover on the pulse valves. Check for solenoid leaks or damage. If pulse valves or solenoid valves and tubing are damaged, replace.
	Solid-State timer failure	Using a voltmeter, check supply voltage to the timer board. Check and replace the fuse on the timer board if necessary. If the fuse is good and input power is present but output voltage to the solenoid is not, replace the timer board. See Solid-State Timer Installation.
	Solid-State timer out of adjustment	See Solid-State Timer and Solid-State Timer Wiring Diagram.
No display on the Delta P Controller	No power to the controller	Use a voltmeter to check for supply voltage.
	Fuse blown	Check the fuse in the control panel. See wiring diagram inside the control panel. Replace if necessary.
Display on Delta P Controller does not read zero when at rest	Out of calibration	Recalibrate as described in Delta P Maintenance Manual.
	With collector discharging outside, differential pressure is present from indoor to outdoor	Recalibrate with the pressure tubing attached as described in the Delta P Maintenance Manual.
Delta P Controller ON, but cleaning system does not start	Pressure tubing disconnected, ruptured, or plugged	Check tubing for kinks, breaks, contamination, or loose connections.
	Not wired to the timing board correctly	Connect the pressure switch on the timer board to Terminals 7 and 8 on TB3.
	Faulty relay	Using a multimeter, test relay for proper closure. Replace if necessary.

Problem	Probable Cause	Remedy
Pulse cleaning never stops	Pressure switch not wired to the timer board correctly	Connect the pressure switch on the timer board to Terminals 7 and 8 on TB3.
	Pressure switch terminals on the timer board jumpered	Remove jumper wire on Solid-State Timer board before wiring to the Delta P Control.
	High Pressure On or Low Pressure Off setpoint not adjusted for system conditions	Adjust setpoints to current conditions.
	Pressure tubing disconnected, ruptured, plugged, or kinked	Check tubing for kinks, breaks, contamination, or loose connections.
Alarm light is ON	Alarm setpoint too low	Adjust to a higher value.
	Excess pressure drop	Check cleaning system and compressed air supply. Replace filters if filters do not clean down.
	Pressure tubing disconnected, ruptured, plugged, or kinked	Check tubing for kinks, breaks, contamination, or loose connections.
Delta P arrow keys to not work	Improper operation	Press and hold one of the three setpoint keys to use arrow keys.
	Programming keys disabled	Remove the Program Disable jumper from Terminals 3 and 4 on TB2.
Cleaning light is ON, but cleaning system not functioning	Improper wiring	Check wiring between the Delta P Control and the timer board, and between the timer board and solenoid valve coils.
	Defective solenoids	Check all solenoid coils for proper operation.
	Timer board not powered	Check power ON light on timer board's LED display. If not illuminated, check the supply voltage to the timer board. Check the fuse on the timer board. Replace if necessary.
	Timer board defective	If LED is illuminated, observe the output display. Install a temporary jumper across the pressure switch terminals. Output levels should flash in sequence. Check output using a multimeter set to 150-Volt AC range. Measure from SOL COM to a solenoid output. The needle will deflect when LED flashes for that output if voltage is present. If LED's do not flash, or if no voltage is present at output terminals during flash, replace the board.

Appendix A - Clean Change Bag-In/Bag-Out Filter and Liner System

Clean Change Bag-In/Bag-Out Filter and Liner System

The Donaldson Torit Downflo® Evolution (DFE) Clean Change Filter and Liner System is a continuous-duty dust collector with cartridge-style filters. Designed for dust containment, each collector may include Bag-In/Bag-Out (BIBO) collars, clamps, bands, and bags for the filters and/or containment options for the hopper. Hopper options may include a single or double inflatable valve and /or 50-ft continuous containment liner for discharge. Contact your Donaldson Torit representative for additional information on custom collector options.



Use extreme caution when changing bags in hazardous material applications.

Wear appropriate PPE including appropriate protective clothing and respirator, to prevent accidental exposure to hazardous material.

When properly used, the Bag-In/Bag-Out Option reduces exposure to contaminants and exposure of contaminants to the atmosphere.

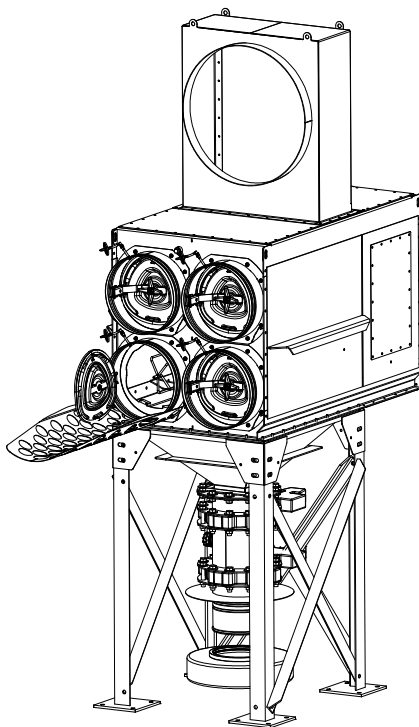

Typical Clean Change Filter and Liner System

Installation of Continuous Liner Collar

The Continuous Liner Collar may not be preinstalled to the collector and may need to be securely fastened to the transition chosen for your specific application.

Remove all packaging from the continuous collar. Place gasket on collar flange and align Liner Collar with transition flange. Fasten the collar to hopper flange using bolts, washers and nuts.

Tighten hardware alternately in steps.

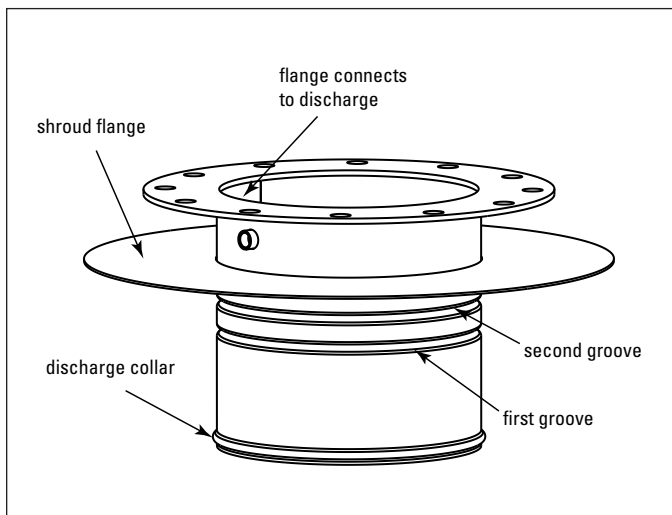

Continuous Liner Collar

Clean Change Liner Pack Change-Out Procedure

Overview

The Donaldson Clean Change Liner System provides a contained approach for the off-loading of powders from the Donaldson Torit Dust Collector. An advantage of the continuous liner system is being able to replace follow-on packs without breaking powder containment for continuous production.

The continuous liner design eliminates cross contamination of powders. The pre-packaged 50-ft liners reduce labor by allowing operators to continuously process powders, instead of stopping production to discharge the hopper.

The liner system attaches directly to the collector via the continuous liner collar. Liner bands and clamps are used to secure the 50-ft liner. Each 50-ft liner provides the equivalent of ten 50 gallon (185 liter) drums in capacity. It is up to the end-user to determine how often to discharge and dispose of the powder.

Clean Change Liner System Components

Initial purchase of Donaldson Clean Change Solution includes:

- 1 - 50-ft continuous liner pack with two integrated rubber gaskets
- 1 - Liner Pack Shroud
- 1 - Metal Band Clamp
- 1 - Locking Outer Clamp (with integrated rubber gasket)
- 1 - Crimping Tool with 100 crimp ties
- 1 - Cutting Tool

Initial Installation of Clean Change Liner System

The Clean Change Liner system should be attached after installation of the Donaldson Dust Collector and before beginning dust collection from the process.

Note: It is recommended that the Donaldson Torit Dust Collector be completely installed before attaching the Clean Change Liner System.

Step by step liner instructions are provided in the ILC Dover Document Number DOC9261 provided separately.

Clean Change BIBO Filter Service

BIBO Filter Removal and Installation

WARNING

Use proper safety and protective equipment when removing contaminants and filters.

Dirty filters may be heavier than they appear.

Use care when removing filters to avoid personal injury and/or property damage.

Turn power off and lock out electrical power sources before performing service or maintenance work.

Turn compressed air supply OFF, bleed and lock out lines before performing service or maintenance work.

CAUTION

Do not operate with missing or damaged filters.

All filters must be removed and installed utilizing the following BIBO procedure to maintain containment.

The following pre-installed items are located in each filter access port to facilitate Bag-In/Bag-Out (BIBO) replacement of the filter:

- Hinged BIBO Cover - provides a safety barrier to contain BIBO bag inside the access port.

- BIBO Bag - safely contains contaminants collected from the filter cartridge in each access port.
- Band Clamp - secures the BIBO bag and O-ring to the collar.
- O-ring gaskets (front and back) - creates a seal around the BIBO bag to secure the bag to the collector.
- Breather Filter Assembly - provides a filtered exhaust for removal of air as the BIBO bag is compressed and stored in the BIBO collar.
- BIBO Support Shelf - provides support to the filter during filter removal and installation and holds hinged BIBO cover out of the way for filter change.

Original Equipment Filter

To ensure performance levels, use only Donaldson Torit replacement filters.

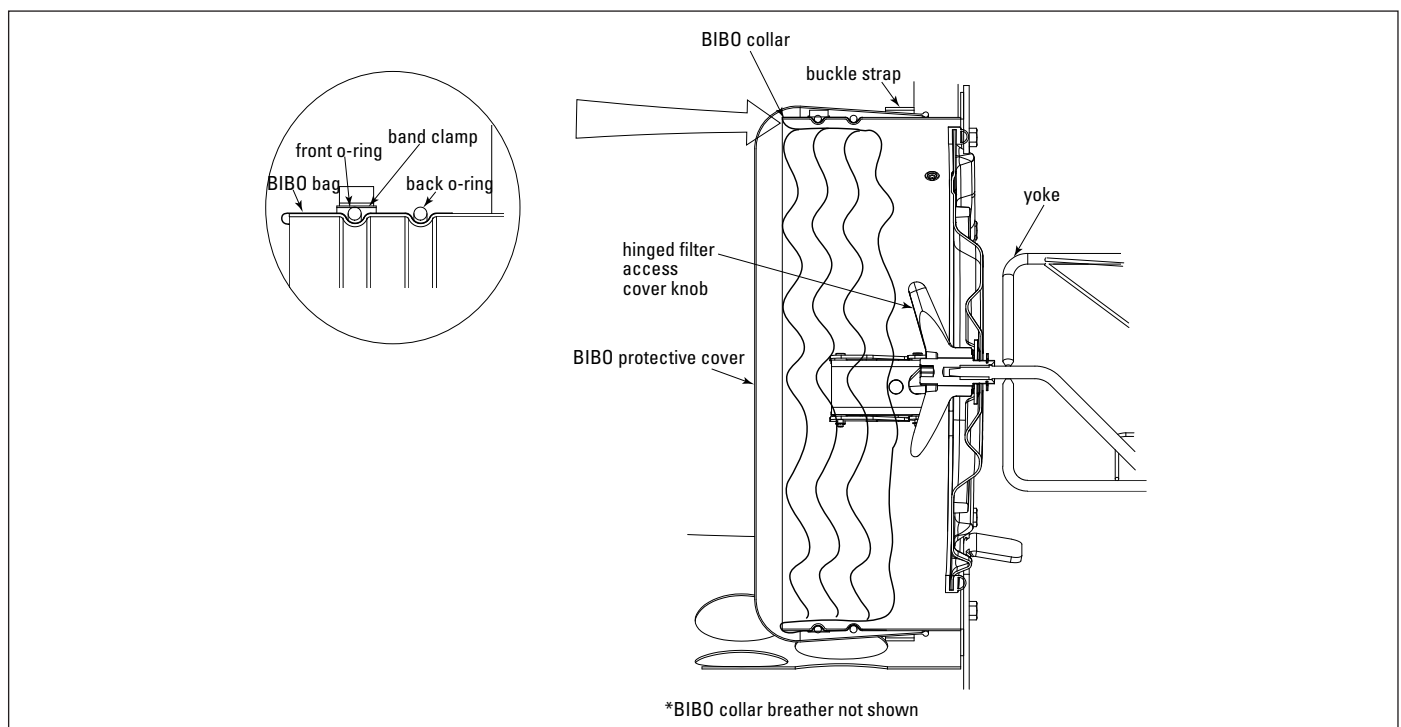

BIBO Pre-Installed Items (Side View)

Initial Filter Installation of BIBO

NOTICE

If filters, Bag-In/Bag-Out (BIBO) bags and BIBO Collar Breathers are not pre-installed, please follow these steps per opening, before the collector is turned on.

1. Unbox necessary number of cartridge filters per model capacity.
2. Open hinged access cover and install cartridge filters gasket end first following procedures outlined in the DFE Installation and Operation Manual.
3. Close and seal filter access cover on collector.
4. Locate BIBO Collar Filter Breather and attach to BIBO Collar.
5. On each collar, place the BIBO bag around the BIBO collar with the integrated O-ring gasket in the back groove (closest to collector) of the collar creating the first seal between the bag and collar. If the Clean Change bag is used, place the bag extension on the opposite side of the access cover hinge to allow for easy access to the filter opening.
6. Place separate (unattached) O-ring gasket in the first groove (furthest from collector) of the collar. This will give two levels of containment between collar and bag.
7. Take open steel band camp, place around the collar and tighten around the integrated gasket (first gasket installed) creating the triple seal for filter change-out containment.
8. With BIBO bag now properly attached to BIBO collar, slowly roll empty bag into collar so that air will disperse through filter breather. Once the bag has dispersed all air it should fit inside collar up against closed filter access cover.
9. Insert BIBO protective cover onto BIBO collar to protect and hold BIBO bag in place. Place buckle strap around the protective cover and tighten to secure protective cover.
10. If hopper discharge is also installed and connected, turn the collector ON.

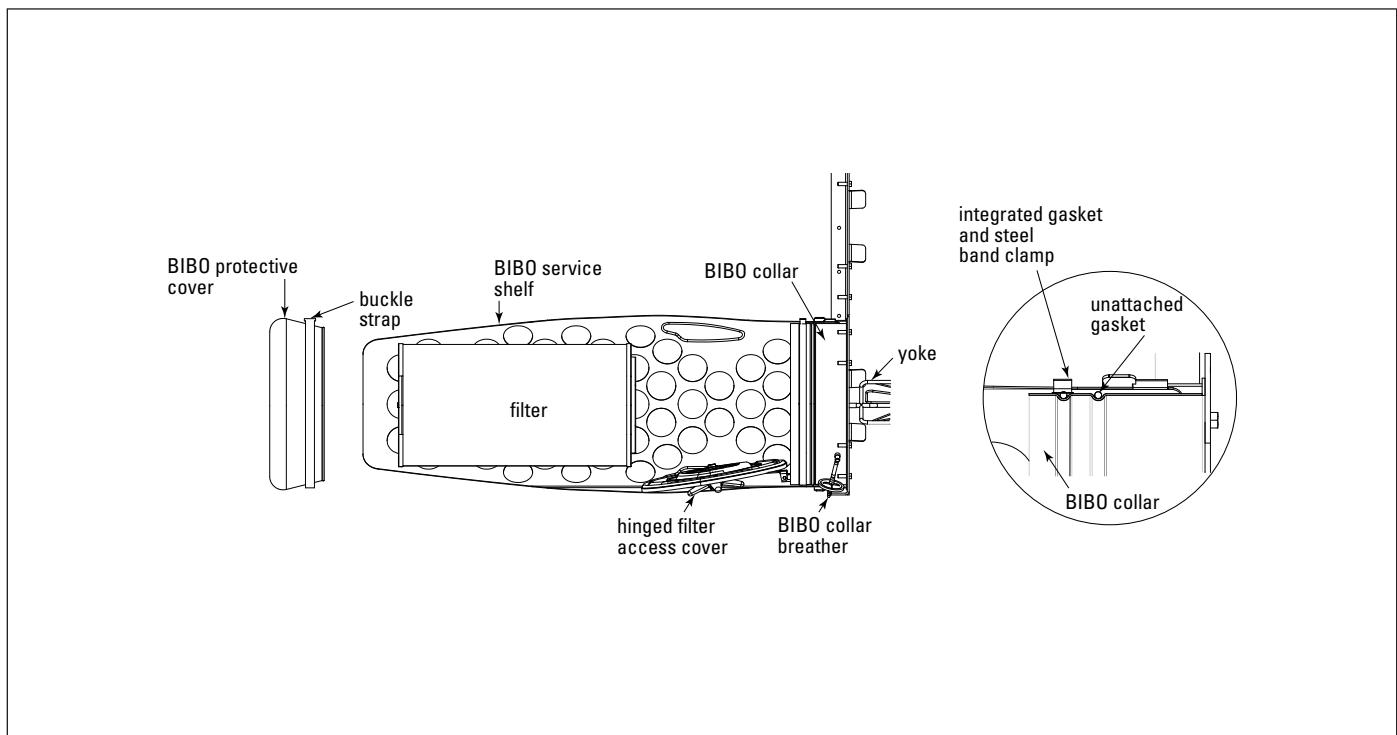

Initial Filter Installation of BIBO

Filter Removal and Installation

WARNING

Use proper safety and protective equipment when removing contaminants and filters.

Dirty filters may be heavier than they appear.

Use care when removing filters to avoid personal injury and/or property damage.

Turn power off and lock out electrical power sources before performing service or maintenance work.

Turn compressed air supply OFF, bleed and lock out lines before performing service or maintenance work.

CAUTION

Do not operate with missing or damaged filters.

Ensure all pre-installed items are present, undamaged and in the correct place before proceeding with filter removal and replacement. See BIBO Pre-Installed Items. Failure to comply may result in containment failure and lead to property damage and/or personal injury.

Clean Change Filter Removal

1. Starting at the top row of filters, securely position the BIBO service shelf on the bracket attached to the BIBO collar.
2. Remove the buckle strap and BIBO protective cover from the collar and set aside.
3. Unroll the BIBO bag from inside of the collar out onto the service shelf.
4. Toward the edge of the BIBO bag is the bag extension to be used as a glove. Using the extension as a glove reach into the bag and open the hinged filter access cover by loosening the knob. Place the filter access cover into the opening on the BIBO service shelf to hold it securely out of the way during filter change operations.
5. To remove the filter, using both hands, position the end of the bag into the filter opening and pull the filter cartridge out to the end of the bag, resting the bag and cartridge on the end of the shelf.
6. Loosely reposition the access cover to the end of the filter yoke.

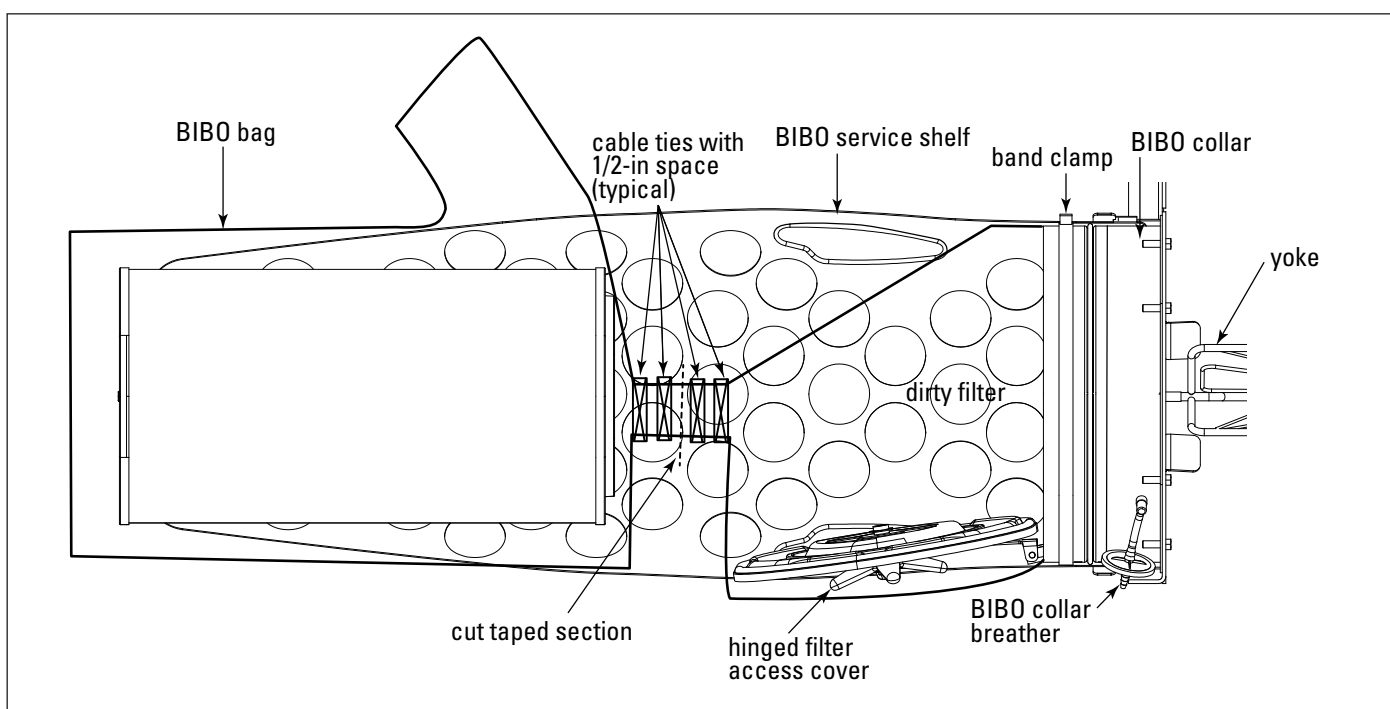

Filter Removal

7. Locate the cleanest section of bag closest to the collar, making sure there is enough bag to collapse into a tight bundle without stretching the bag too tight.
8. Wrap and hand tighten two cable ties around the collapsed bag section between the collar and filter cartridge, spacing the cable ties approximately 1/2-in apart.
9. Compress as much air as possible from the BIBO bag and BIBO bag extension.
10. Securely tighten the two cable ties with the supplied cable tie tool at the maximum setting.
11. Cut the compressed BIBO bag between the two cable ties leaving one tie around each section.
12. Place tape over the cut end of the BIBO bag containing the filter and both cable ties.
13. Securely wrap tape around the cut end of the bag covering a minimum of 3-inches around the bag end.

14. Properly dispose of the BIBO bag containing the filter.
15. If collector contains two filters per opening, gently push the stub into the collar.
16. Open a new bag and place the open end around the bag collar as close to the collector as possible. The bag stub is now inside the new bag.
17. Loosen the safety strap, slide the new bag under the strap, and the bag stub toward the end of the collar. Tighten the safety strap to hold the new bag only and carefully remove the bag stub from the collar.
18. Use the filter ejector rod to pull the second filter toward the bag collar until within reach.
19. Repeat steps 5-14.

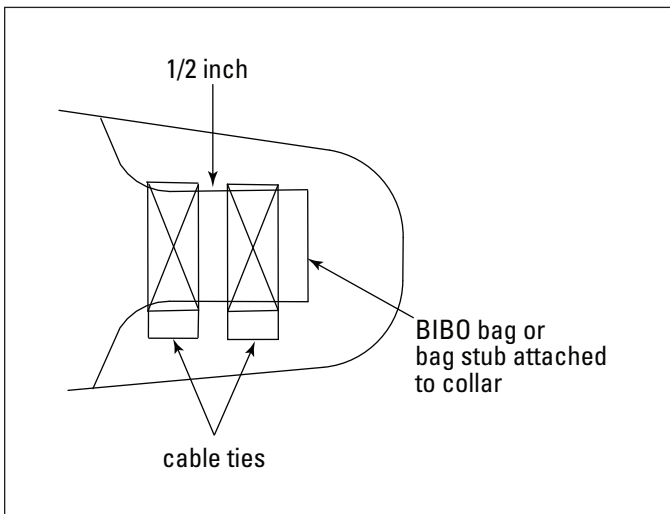

Tape Wrap (Steps 10-13)

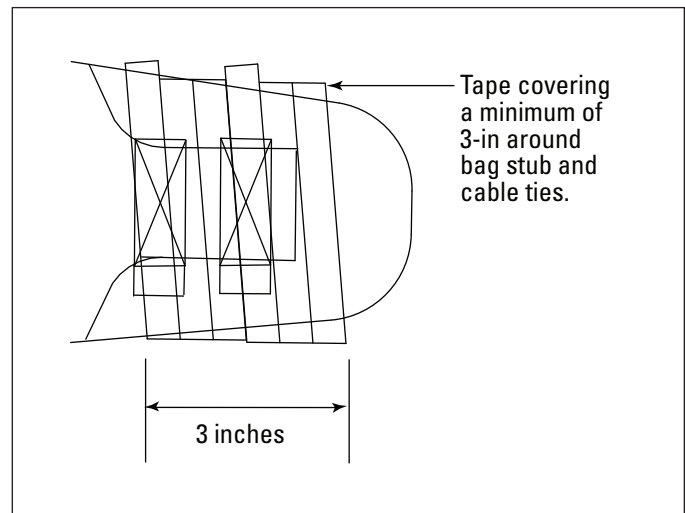

Tape Wrap (Steps 14-17)

- 20. Carefully remove the band clamp from the collar.
- 21. Move the front (integrated) O-ring gasket back 1/4-in in front of the back (unattached) O-ring gasket.



Do not remove bag from collar.
Failure to comply will result in containment exposure.

- 22. Slowly and carefully slide the bag and both O-ring gaskets towards the front of the collar until the back o-ring gasket engages the front collar groove (furthest from collector) illustrated below.

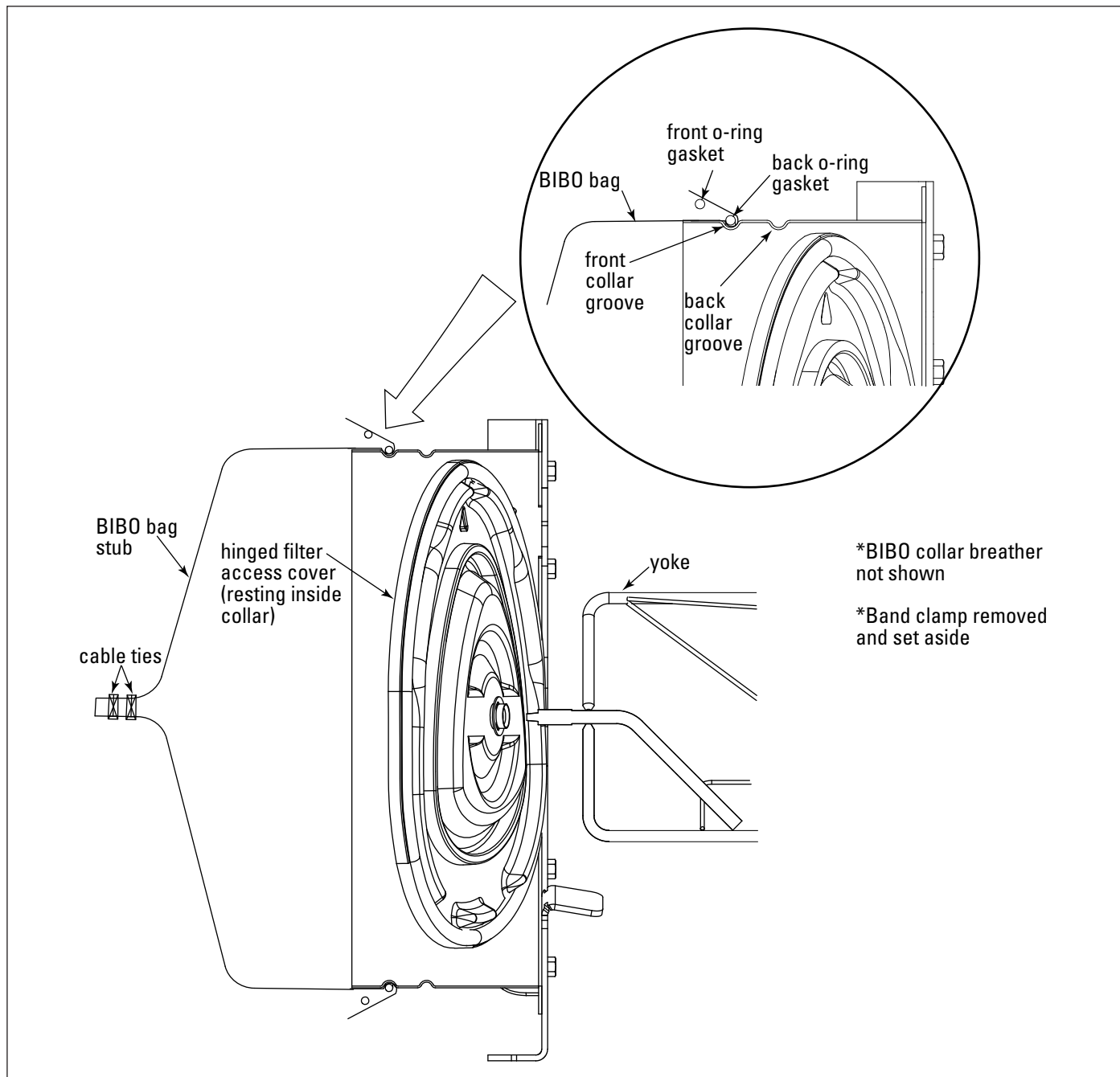

*BIBO collar breather not shown
*Band clamp removed and set aside

Bag Stub Repositioning (Side View)

Clean Change Filter Installation

1. Place a clean filter cartridge in a new BIBO bag with the filter gasket side facing the bag opening toward the collar on the collector.
2. Place clean filter and BIBO bag on BIBO service shelf.
3. Slide the new BIBO bag over the collar and past the bag stub and bag stub O-ring gasket. Position the bag extension on the opposite side of the access cover hinge
4. Install the new front (integrated) O-ring gasket in the back groove.
5. Install the back (unattached) O-ring gasket adjacent to the back O-ring gasket.
6. Reinstall the band clamp on the front O-ring gasket (closest to collector).
7. Invert the BIBO bag extension with both hands and pull off the bag stub section and O-ring gaskets into the new BIBO bag. O-ring gaskets will automatically pull off with it.
8. Move the back O-ring gasket into the front groove.
9. Remove the band clamp and reinstall on the back O-ring gasket.

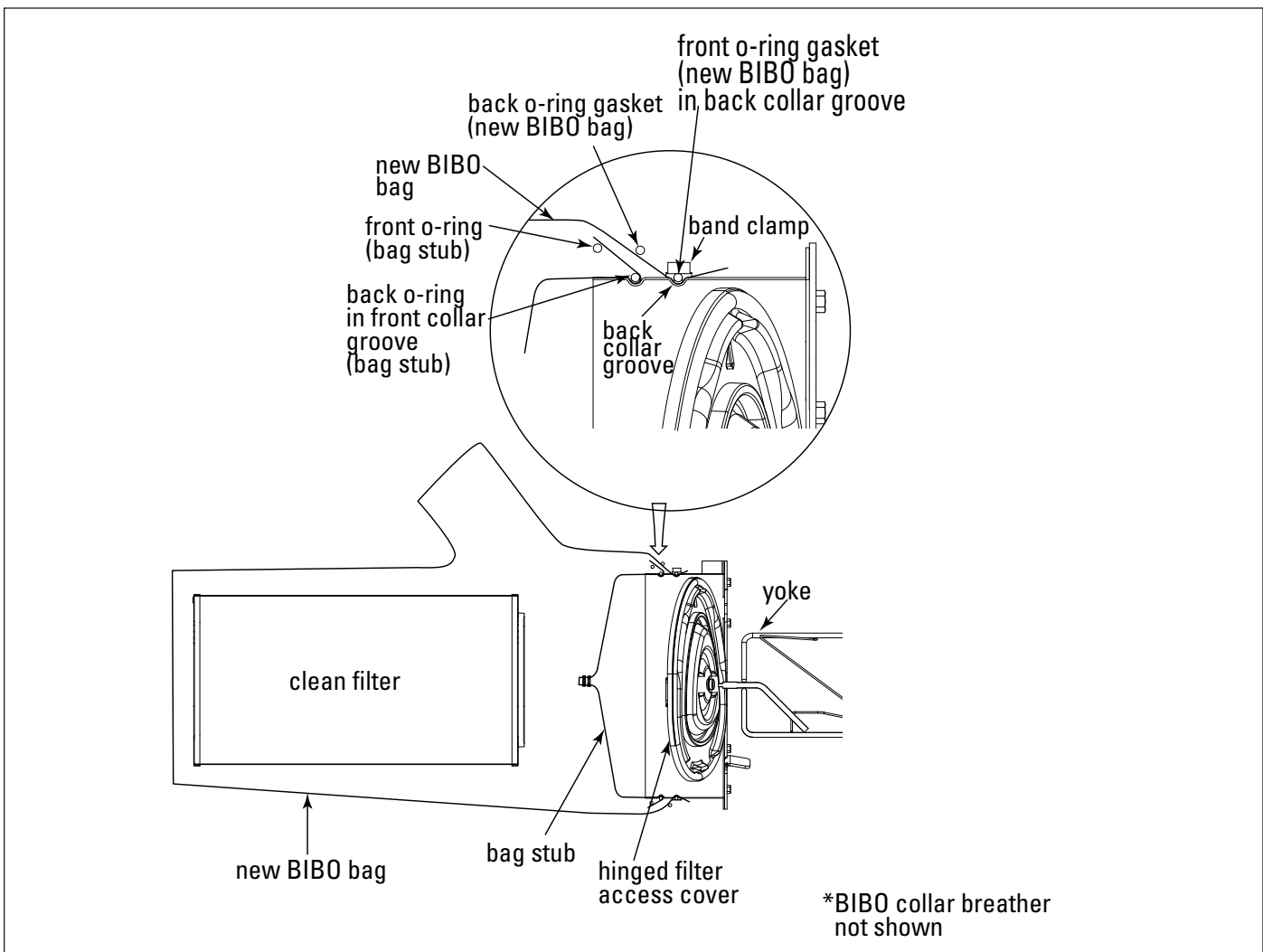

Filter Installation

10. Install the filter with gasket end toward collector.

Using the BIBO bag as a glove, support the filter with both hands while positioning the alignment features and slide the gasket end of the new filter onto the end of the suspension yoke.

CAUTION

Do not allow the bag to become pinched between the access cover and sealing surfaces. Failure to comply may result in containment failure.

NOTICE

The filter shape and yoke work together to ensure proper filter alignment during filter installation. To assist with alignment, an alignment mark (\triangle) at the top of the filter endcap (non-gasketed end) must match with the alignment mark (∇) at the top of the filter access opening.

If knob fails to thread onto yoke, on the opposite side of the hinge, apply slight pressure to the access cover using other hand. Continue to turn knob to start threading onto the yoke.

11. Close the filter access cover and tighten onto the yoke.
12. Slowly roll bag back into the collar to allow air to escape through the BIBO collar breather (see Bag Setup).
13. Install the BIBO protective cover and secure with buckle strap.
14. Turn electrical power and compressed air supply ON before starting collector.

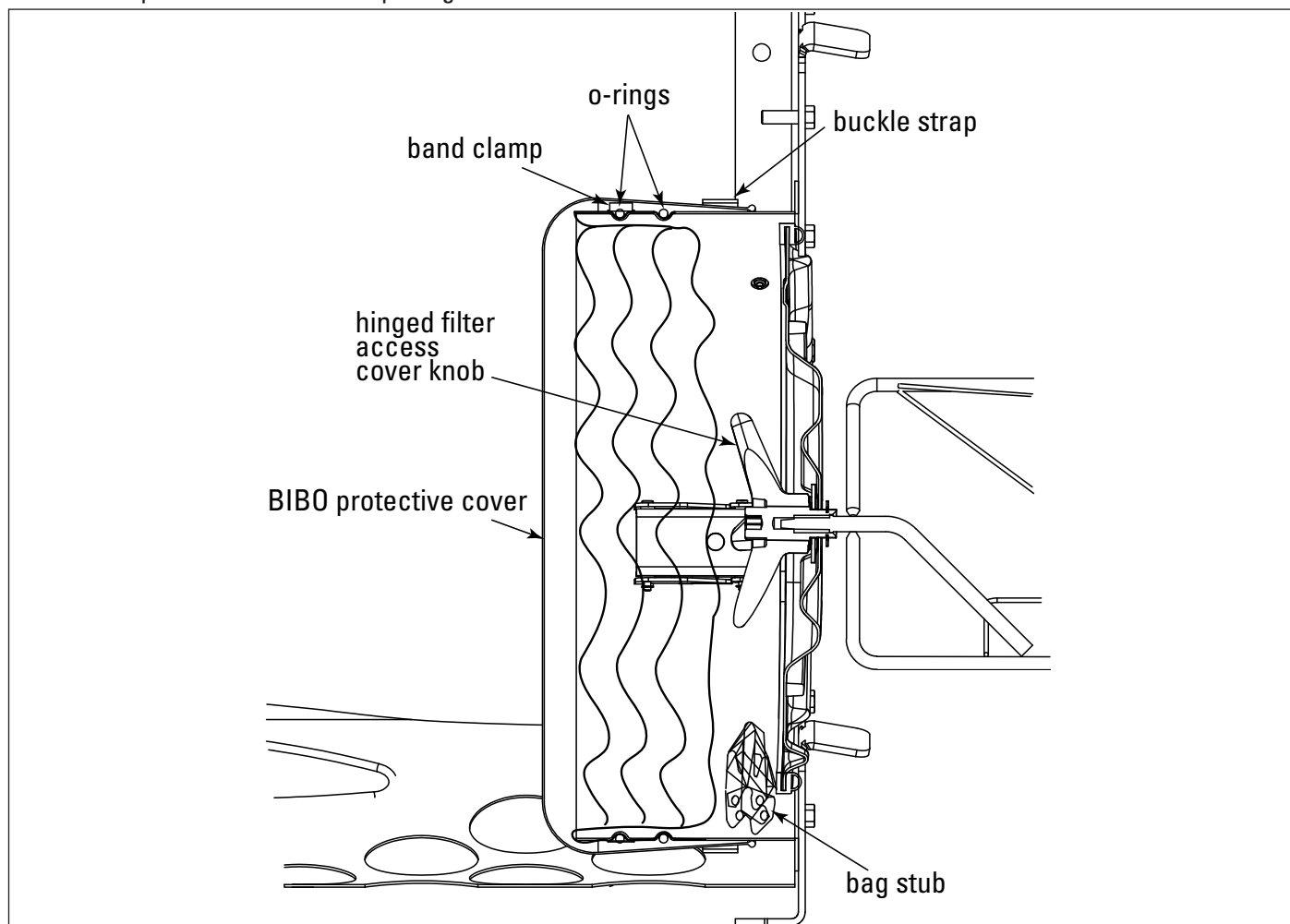

Bag Setup (Side View)

BIBO Collar Breather Installation

The BIBO collar breather provides a means for the air to escape during bag compression into the collar without breaking containment. Use the following procedure if replacement of the breather filter should become necessary.

1. Press on the metal trigger to release the breather filter and disconnect the assembly.
2. Remove and properly dispose of the breather filter.
3. Insert new breather filter in the female quick disconnect ensuring it is securely installed.

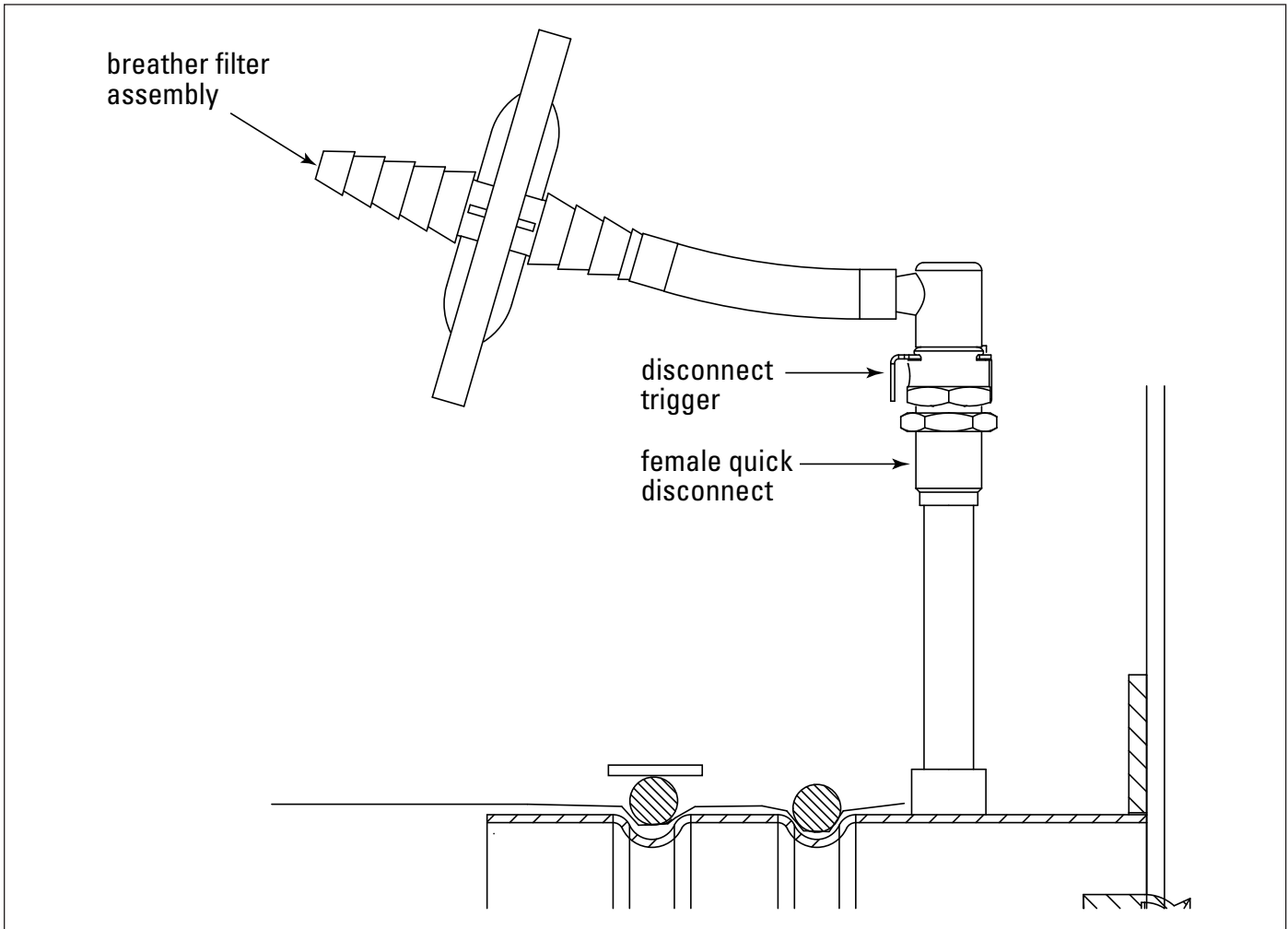

BIBO Collar Breather

Bag-Out

Bag out collars are available for capturing nuisance, non-hazardous dust that may fall from dirty filters during the filter change.

Note: This is not for contamination prevention or full containment purposes and is not a substitute for BIBO. Contact Donaldson Torit for selection assistance.

1. Turn off the power to the collector.
2. Begin filter replacement at one of the top filter access ports. Continue by replacing the remaining filters in the top row. Proceed to replace the filters in the next row.

Replacing the filters row by row starting at the top will help limit dusting during replacement.

3. Remove access cover by turning knob counterclockwise.

WARNING

Do not use the access cover features as climbing equipment.

Use safe practices for maintenance and installation.

Do not drop filters.

4. Break the seal between the filter cartridge and the sealing surface.

5. Place the bag out bag around collar surrounding port hole. Starting from the bottom of the collar, roll the bag opening over the edge of the collar. With both hands, move around the collar until the bag is in position all the way around the collar. Secure bag on collar with buckle strap.
6. Using the bag as a glove, pull the filter into the bag.
7. Remove the buckle strap securing the bag. Place it aside for use on the next bag. Support filter and bag when removing to prevent dust spilling. Properly dispose of bag with the filter inside of it.
8. Repeat steps 5-7 for second filter on suspension yoke.

9. Inspect and clean the sealing surface if necessary.

NOTICE

Clean dust from gasket dealing area to ensure a positive filter

gasket seal.

10. Clean any dust from the yoke threads that may have accumulated during the filter removal.
11. Check for an accumulation of dust in the storage area and empty as necessary.
12. Follow filter installation instructions found in the Maintenance Information section of this manual.

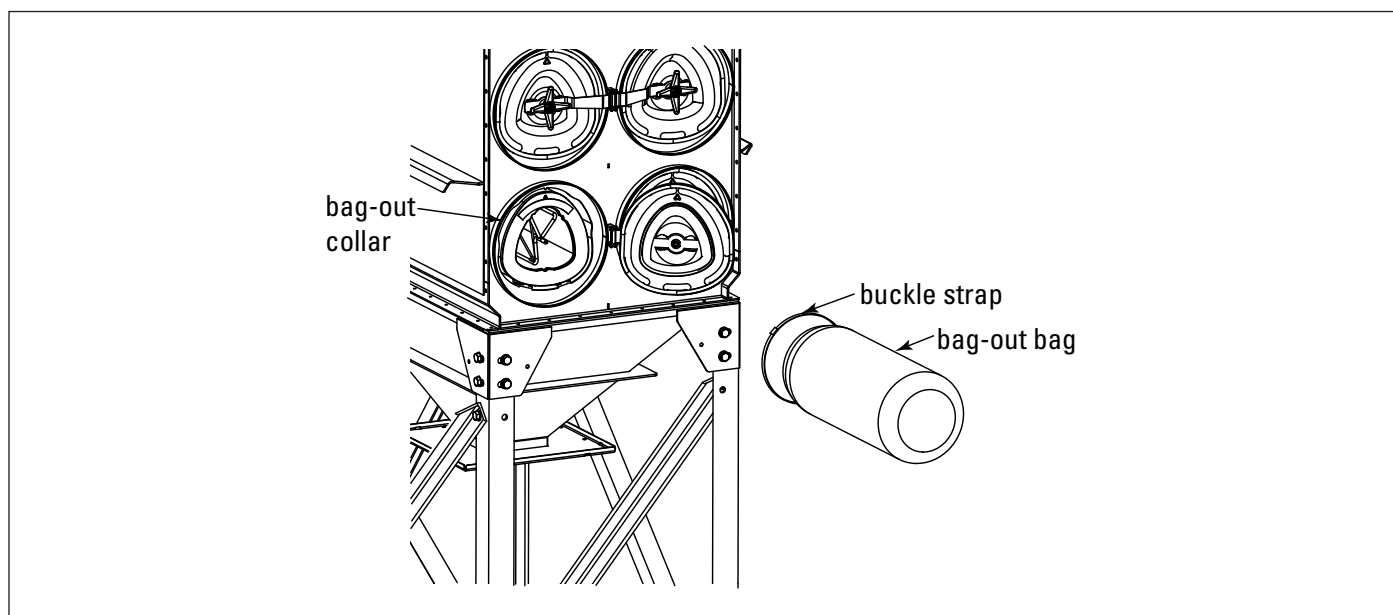

Bag-Out

Hopper Bag-In/Bag-Out Installation

1. Place the BIBO hopper bag with plastic liner inside the 55-gallon drum. Position the liner upright inside the drum. It will expand and hold the bag securely to the inside of the 55-gallon drum.

Note: The 55-gallon drum is supplied by others.

2. Position the 55-gallon drum under the drum cover, attached to the hopper.
3. Draw the open end of the bag around the drum cover and through the drum cover clamp assembly. The bag will now be outside the drum cover but inside the drum cover clamp assembly.
4. Slide the open end of the bag around the collar adapter, which is located under the slide gate. Use the buckle strap to securely fasten the bag to the collar adapter.
5. Position the drum cover carefully on top of the 55-gallon drum.
6. Secure the 4 clamps of the drum cover clamp assembly to the drum by tightening the knobs. Make sure the clamps engage the top rim of the 55-gallon drum.

First Fit Bag-Out

Note: Turn pulse cleaning system OFF before using the hopper Bag-In/Bag-Out process.

1. Leaving the bag securely strapped to the collar adapter, loosen the four clamps on the drum cover clamp assembly.
2. Lift the ring and drum cover assembly up from the 55-gallon drum. A helper should hold the drum cover assembly out of the way.
3. Close and seal the bag near the drum using two cable ties placed approximately 2-inches apart. Cut the bag between the cable ties.
4. Remove the drum from under the hopper and properly dispose of drum and bag or bag only.
5. Loosen rubberized band clamp and pull liner system to desired length and place inside the 55-gallon drum. Retighten rubberized band clamp.

The Donaldson Torit Warranty

Donaldson does not warrant against damages due to corrosion, abrasion, normal wear and tear, product modification, or product misapplication. Donaldson also makes no warranty whatsoever as to any goods manufactured or supplied by others including electric motors, fans and control components. After Donaldson has been given adequate opportunity to remedy any defects in material or workmanship, Donaldson retains the sole option to accept return of the goods, with freight paid by the purchaser, and to refund the purchase price for the goods after confirming the goods are returned undamaged and in usable condition. Such a refund will be in the full extent of Donaldson's liability. Donaldson shall not be liable for any other costs, expenses or damages whether direct, indirect, special, incidental, consequential or otherwise. The terms of this warranty may be modified only by a special warranty document signed by a Director, General Manager or Vice President of Donaldson. Failure to use genuine Donaldson replacement parts may void this warranty. THERE EXIST NO OTHER REPRESENTATIONS, WARRANTIES OR GUARANTEES EXCEPT AS STATED IN THIS PARAGRAPH AND ALL OTHER WARRANTIES INCLUDING MERCHANTABILITY AND FITNESS FOR A PARTICULAR PURPOSE, WHETHER EXPRESS OR IMPLIED ARE HEREBY EXPRESSLY EXCLUDED AND DISCLAIMED.



Parts and Service

For genuine Donaldson replacement filters and parts, call the Parts Express Line. For faster service, have unit's model and serial number, quantity, part number, and description available.

Donaldson Australasia
Tel: 1800 503 878 (AU)
Tel: 0800 743 387 (NZ)
Website: www.donaldsonfilters.com.au

Donaldson Japan
Tel: +81 42 540 4114
Website: www.donaldson.co.jp

Donaldson Southeast Asia
Tel: +65 6349 8168
Website: www.asia.donaldson.com

Donaldson China
Tel: 400 820 1038
Website: www.donaldson.cn

Donaldson Korea
Tel: +82 251 733 33
Website: www.donaldson.co.kr

Donaldson USA
Tel: +1 800 365 1331
Website: www.donaldsontorit.com

Donaldson South Asia
Tel: +91 124 480 7536
Website: www.india.donaldson.com

Donaldson Europe
Tel: +32 16 383 811
Website: www.donaldson.com

Donaldson Company, Inc. is the leading designer and manufacturer of dust, mist, and fume collection equipment used to control industrial-air pollutants. Our equipment is designed to help reduce occupational hazards, lengthen machine life, reduce in-plant maintenance requirements, and improve product quality.