

Dalamatic Cased Dust Collectors

Series DLM 15

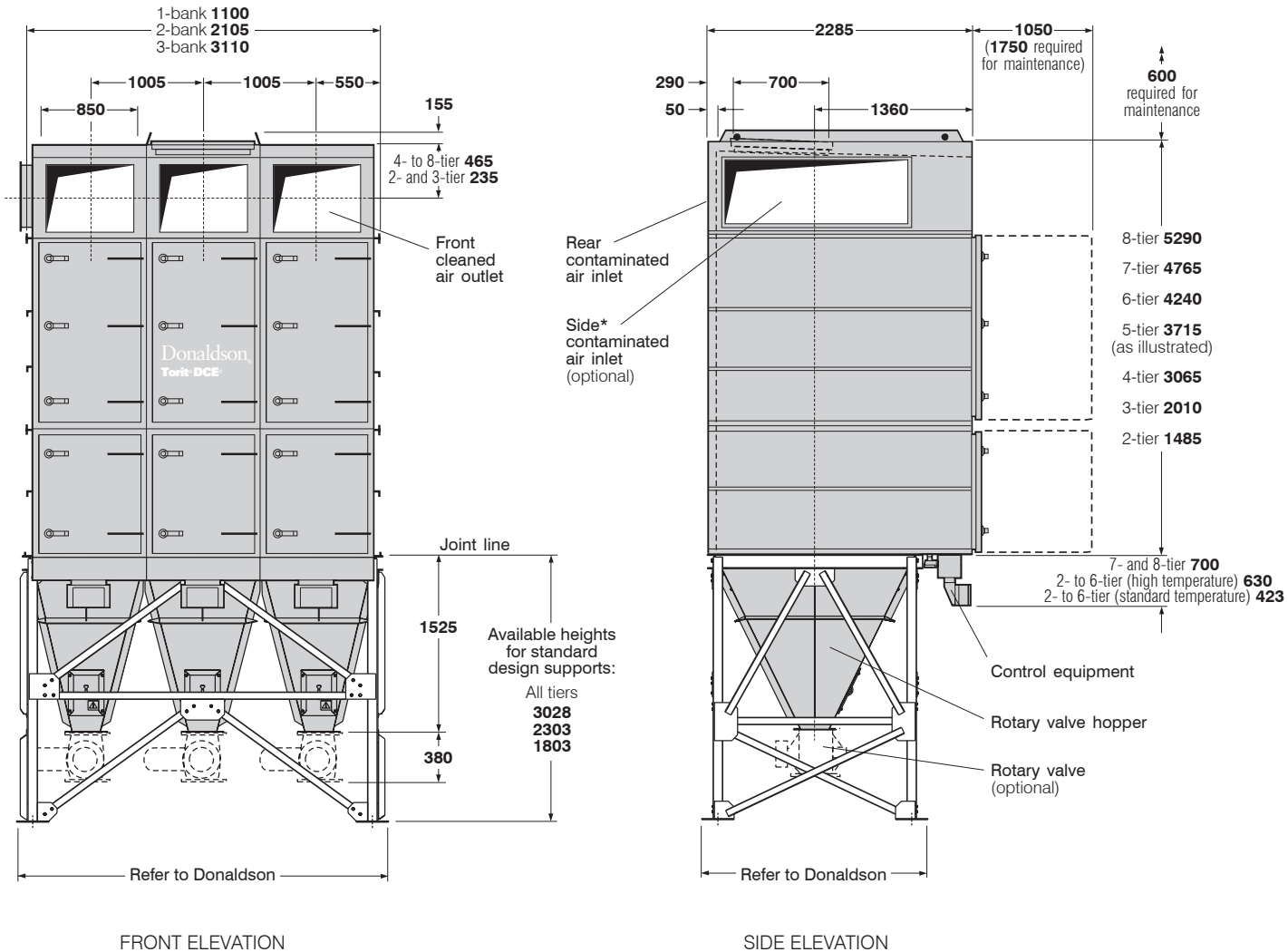

DALAMATIC CASED COLLECTOR WITH ROTARY VALVE HOPPERS

3-bank, 5-tier collector (DLM 3/5/15) illustrated. Larger collectors are assembled on site from suitable combinations of the above sizes.

*4- to 8-tier collectors; 2- and 3-bank either end, 4- to 6-bank both ends.

NOTE: For foundation details refer to Donaldson.

SPECIFICATIONS

Designation	Number of banks (a)	Number of tiers (b)	Number of cells (a x b)	Filtration area	Air volume – FAD* at 12 sec. intervals	
DLM 1/2/15†	1	2	2	30 m ²	7.4 m ³ /h	4.3 cfm
DLM 1/3/15†	1	3	3	45 m ²	9.5 m ³ /h	5.6 cfm
DLM 1/4/15	1	4	4	60 m ²	13.7 m ³ /h	8.1 cfm
DLM 1/5/15	1	5	5	75 m ²	13.7 m ³ /h	8.1 cfm
DLM 1/6/15	1	6	6	90 m ²	24.9 m ³ /h	14.6 cfm
DLM 1/7/15	1	7	7	105 m ²	28.9 m ³ /h	17.0 cfm
DLM 1/8/15	1	8	8	120 m ²	28.9 m ³ /h	17.0 cfm
DLM 2/2/15†	2	2	4	60 m ²	14.7 m ³ /h	8.7 cfm
DLM 2/3/15†	2	3	6	90 m ²	19.0 m ³ /h	11.2 cfm
DLM 2/4/15	2	4	8	120 m ²	27.5 m ³ /h	16.2 cfm
DLM 2/5/15	2	5	10	150 m ²	27.5 m ³ /h	16.2 cfm
DLM 2/6/15	2	6	12	180 m ²	49.8 m ³ /h	29.3 cfm
DLM 2/7/15	2	7	14	210 m ²	57.7 m ³ /h	34.0 cfm
DLM 2/8/15	2	8	16	240 m ²	57.7 m ³ /h	34.0 cfm
DLM 3/2/15†	3	2	6	90 m ²	22.1 m ³ /h	13.0 cfm
DLM 3/3/15†	3	3	9	135 m ²	28.6 m ³ /h	16.8 cfm
DLM 3/4/15	3	4	12	180 m ²	41.1 m ³ /h	24.2 cfm
DLM 3/5/15	3	5	15	225 m ²	41.1 m ³ /h	24.2 cfm
DLM 3/6/15	3	6	18	270 m ²	74.7 m ³ /h	43.9 cfm
DLM 3/7/15	3	7	21	315 m ²	86.6 m ³ /h	51.0 cfm
DLM 3/8/15	3	8	24	360 m ²	86.6 m ³ /h	51.0 cfm

Larger collectors are assembled on site from suitable combinations of the above sizes

There is no limit to the number of banks which may be joined together – e.g. DLM 10/8/15 (80 cells, 1200 m² filtration area)

*Pulse duration: 60 ms (2- to 5-tier), 100 ms (6- to 8-tier). Recommended atmospheric air volume of clean, dry compressed air at the following maximum pressures:

- All 2-tier collectors: 3.4 bar (50 psig) ● All 3-tier collectors: 3.8 bar (55 psig)
- All 4- and 5-tier collectors: 5.2 bar (75 psig) ● All 6- to 8-tier collectors: 6.2 bar (90 psig)

†Supplied pre-assembled. All other collectors are supplied in two or more sections.

DESIGN LIMITS

Standard equipment

Temperature range: (alternatives according to type of sealer used): (1) –10° to +60°C (2) –10° to +200°C

Pressure limits: (a) –500 mm WG (b) –1140 mm WG (For positive pressures please refer to Donaldson)

Dimension tolerances: ±5 mm on main dimensions; ±2 mm on detail dimensions

For use in a potentially explosive atmosphere (Directive 94/9/EC) satisfying the requirements for group II category 2G or 2D and 3G or 3D T135°C, please refer to Donaldson.

Standard supports (up to 3-bank collectors)

Site wind speed: 102 m/s

Snow load: 0.8 kN/m²

Site exposure category: Country

Live load: 10 kN/m²

Dust density: 1200 kg/m³ (allowance for hopper full of dust)

Reaction force from explosion: According to EN14491

NOTE: Do not omit bracing without consulting Donaldson

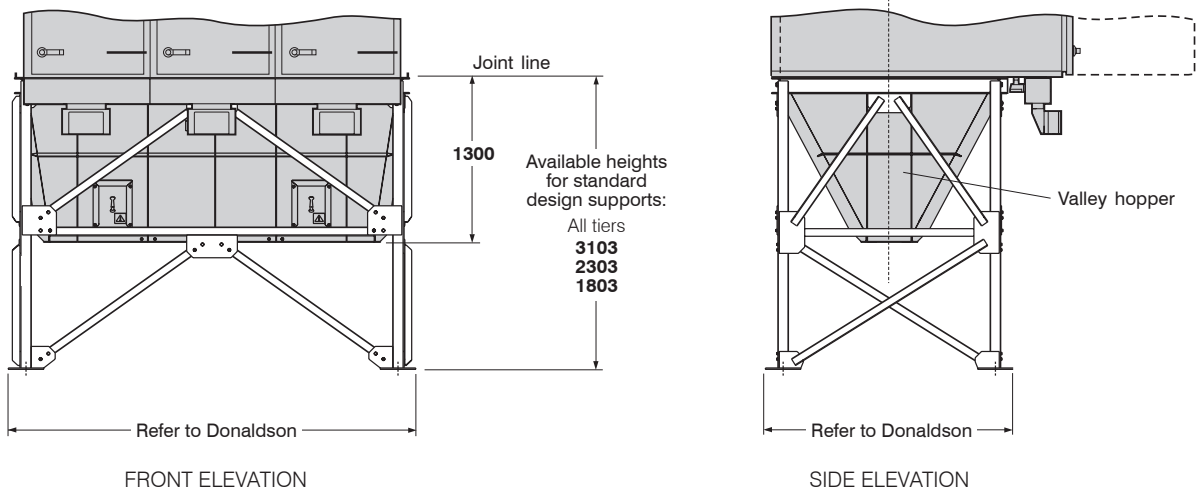

MULTI-BANK COLLECTOR WITH VALLEY HOPPER FOR ATTACHMENT TO SCREW CONVEYOR

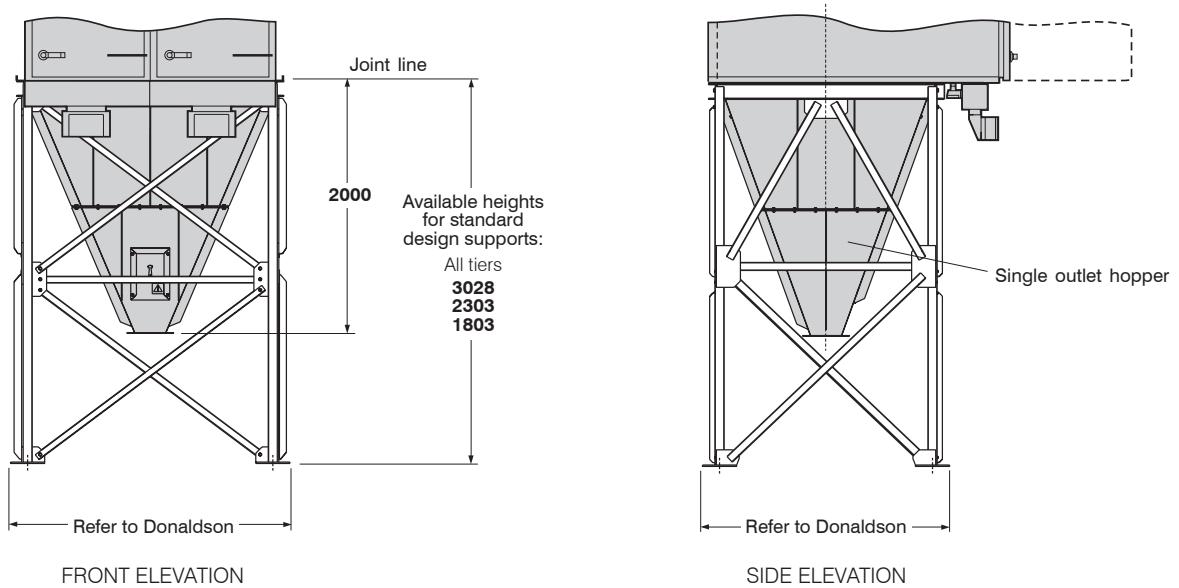

2-BANK COLLECTOR WITH SINGLE OUTLET HOPPER

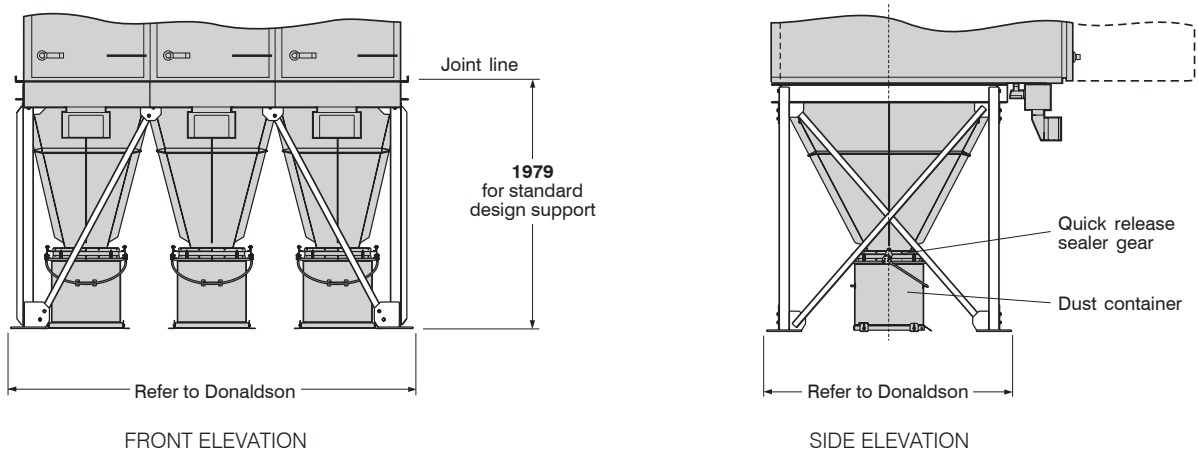

MULTI-BANK COLLECTOR WITH DUST CONTAINERS

APPROXIMATE NET WEIGHTS

Collector and control equipment only

	1-bank	2-bank	3-bank	4-bank	5-bank	6-bank	7-bank	8-bank	9-bank	10-bank
2-tier	633 kg	1480 kg	2169 kg	2930 kg	3589 kg	4308 kg	5069 kg	5758 kg	6447 kg	7208 kg
3-tier	1034 kg	1918 kg	2802 kg	3806 kg	5175 kg	5574 kg	6578 kg	7462 kg	8346 kg	9350 kg
4-tier	1373 kg	2544 kg	3690 kg	5058 kg	6204 kg	7350 kg	8718 kg	9864 kg	11010 kg	12378 kg
5-tier	1662 kg	3108 kg	4532 kg	6186 kg	7613 kg	9034 kg	10688 kg	12172 kg	13545 kg	15190 kg
6-tier	1906 kg	3533 kg	5136 kg	7036 kg	8669 kg	10242 kg	12142 kg	13745 kg	15348 kg	17248 kg
7-tier	2149 kg	3971 kg	5769 kg	7912 kg	9710 kg	11508 kg	13651 kg	15449 kg	17247 kg	19390 kg
8-tier	2393 kg	4396 kg	6373 kg	8762 kg	10739 kg	12716 kg	15105 kg	17082 kg	19059 kg	21448 kg

For larger sizes please refer to Donaldson. All weights shown indicate heaviest configuration.

Standard hopper and support only

	2- to 4-tier			5- to 8-tier		
	1-bank	2-bank	3-bank	1-bank	2-bank	3-bank
Rotary valve hopper and support – 1803 mm high	435 kg	690 kg	960 kg	500 kg	780 kg	1175 kg
Rotary valve hopper and support – 2303 mm high	480 kg	780 kg	1090 kg	575 kg	1005 kg	1440 kg
Rotary valve hopper and support – 3028 mm high	530 kg	845 kg	1185 kg	655 kg	1120 kg	1610 kg
Valley hopper and support – 1803 mm high	Not applicable	645 kg	845 kg	Not applicable	680 kg	965 kg
Valley hopper and support – 2303 mm high	Not applicable	740 kg	965 kg	Not applicable	900 kg	1240 kg
Valley hopper and support – 3103 mm high	Not applicable	790 kg	1105 kg	Not applicable	1005 kg	1450 kg
Single outlet hopper and support – 1803 mm high	Not applicable	655 kg	Not applicable	Not applicable	745 kg	Not applicable
Single outlet hopper and support – 2303 mm high	Not applicable	745 kg	Not applicable	Not applicable	970 kg	Not applicable
Single outlet hopper and support – 3028 mm high	Not applicable	810 kg	Not applicable	Not applicable	1085 kg	Not applicable
Hopper and support with dust container	458 kg	716 kg	984 kg	503 kg	861 kg	1169 kg

ELECTRICAL REQUIREMENTS

IPC or IPC (ΔP) Controller:

Valves: 10-way
Voltage input: AC Version: 105-120V, 200-240V±10% DC Version: 24V

Delta P-C01 Controller:

Valves: 10-way
Voltage input: AC Version: 110V, 220V±10%

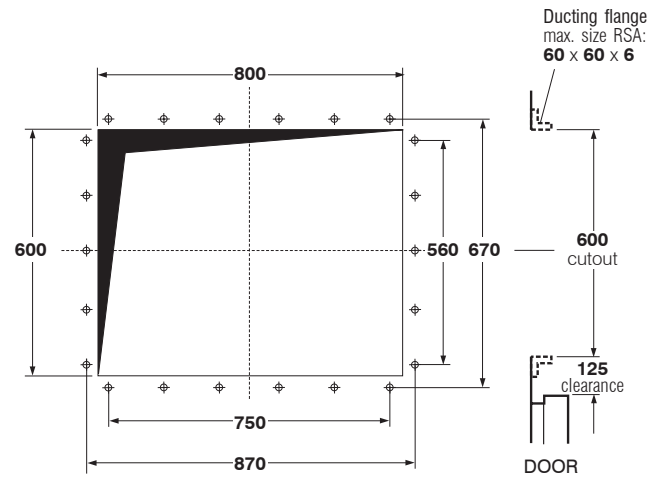
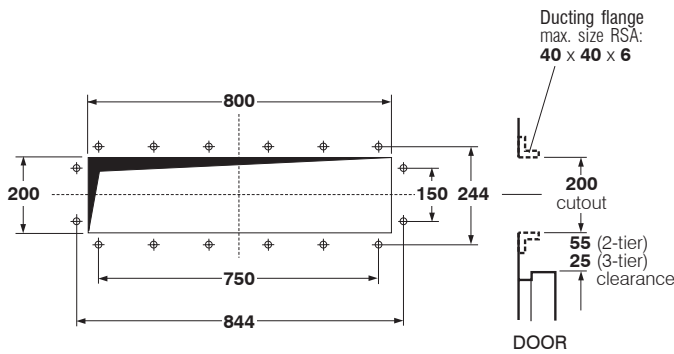

Rear contaminated air inlet and front cleaned air outlet for 2- and 3-tier collectors

All bolt holes $\varnothing 12$ mm for M10 bolts.
Pitch centres: 150 mm.

Rear contaminated air inlet and front cleaned air outlet for 4- to 8-tier collectors

All bolt holes $\varnothing 12$ mm for M10 bolts.
Pitch centres: 150 mm horizontally; 140 mm vertically.

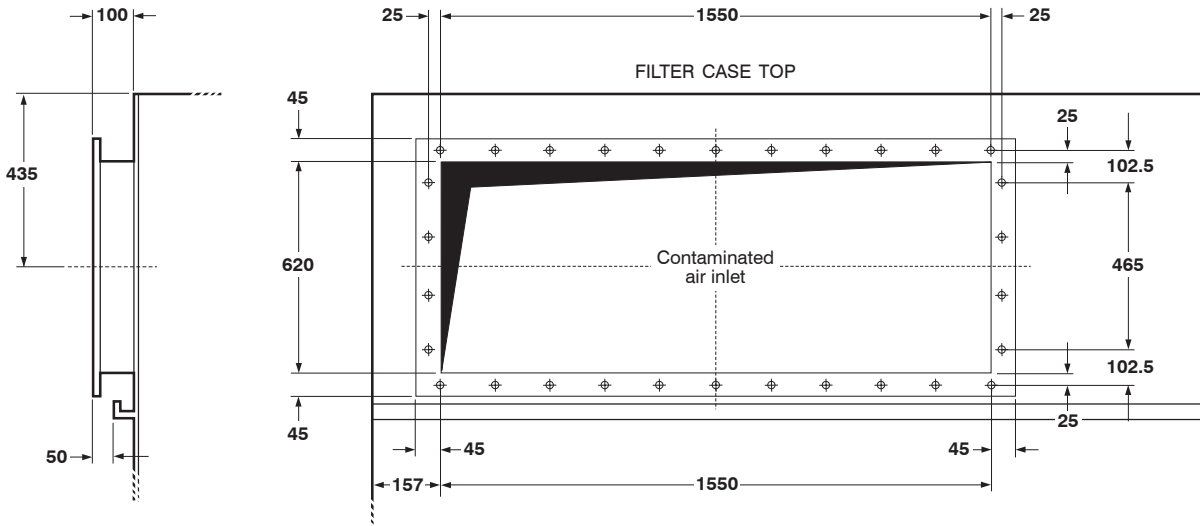

Optional side contaminated air inlet for 4- to 8-tier collectors; 2- and 3-bank either end, 4- to 6-bank both ends

All bolt holes $\varnothing 12$ mm for M10 bolts. Pitch centres: 155 mm except where shown.
NOTE: Consult with Donaldson for suitability.

CONTAMINATED AIR INLET AND CLEANED AIR OUTLET CONNECTION DETAILS

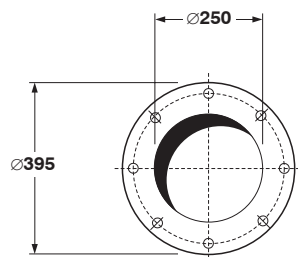

Rotary valve flange (for rotary valve supplied by Donaldson)

All holes $\varnothing 14$ mm for M12 bolts equally spaced on 350 mm p.c.d.

ROTARY VALVE OUTLET FLANGE DETAILS

Dalamatic Cased Dust Collectors – Series DLM 15

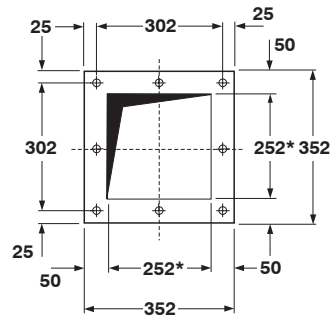

Rotary valve hopper and single outlet hopper flange

All bolt holes \varnothing 14 mm for M12 bolts. Pitch centres: 151 mm.

*Inside dimensions of hopper outlet = 240 x 240 mm.

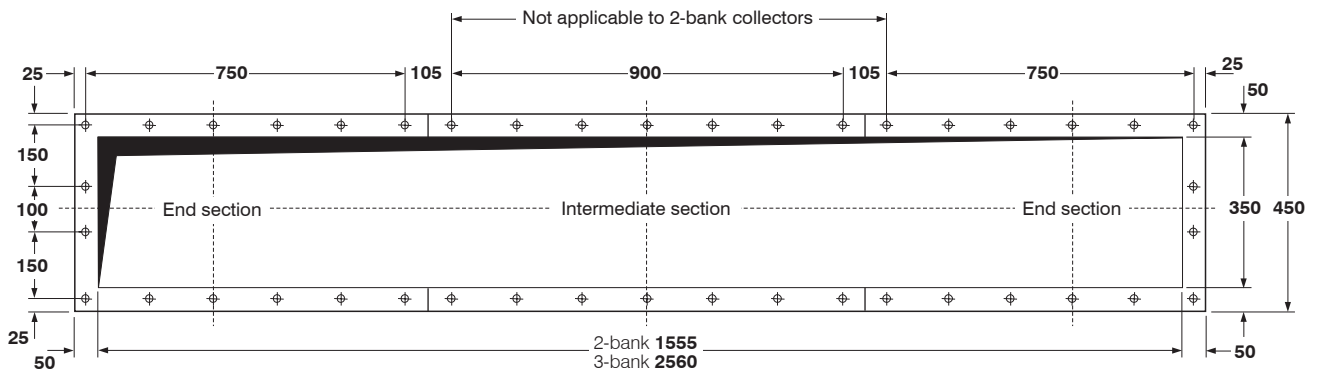

Valley hopper flange

(3-bank illustrated).

All holes 12 x 20 mm slots, parallel to long edge. Pitch centres: 150 mm except where shown.

HOPPER OUTLET FLANGE DETAILS

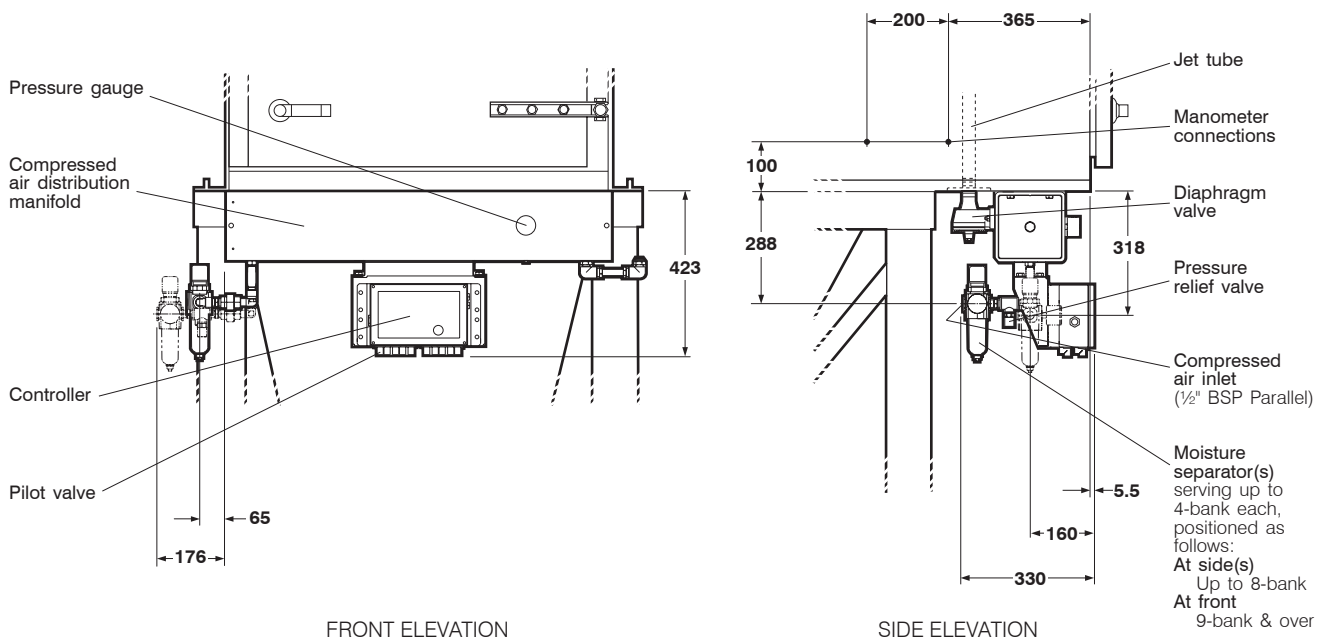

2-, 3-, 4-, 5- and 6-tier collectors (standard temperature)

CONTROL EQUIPMENT DETAILS

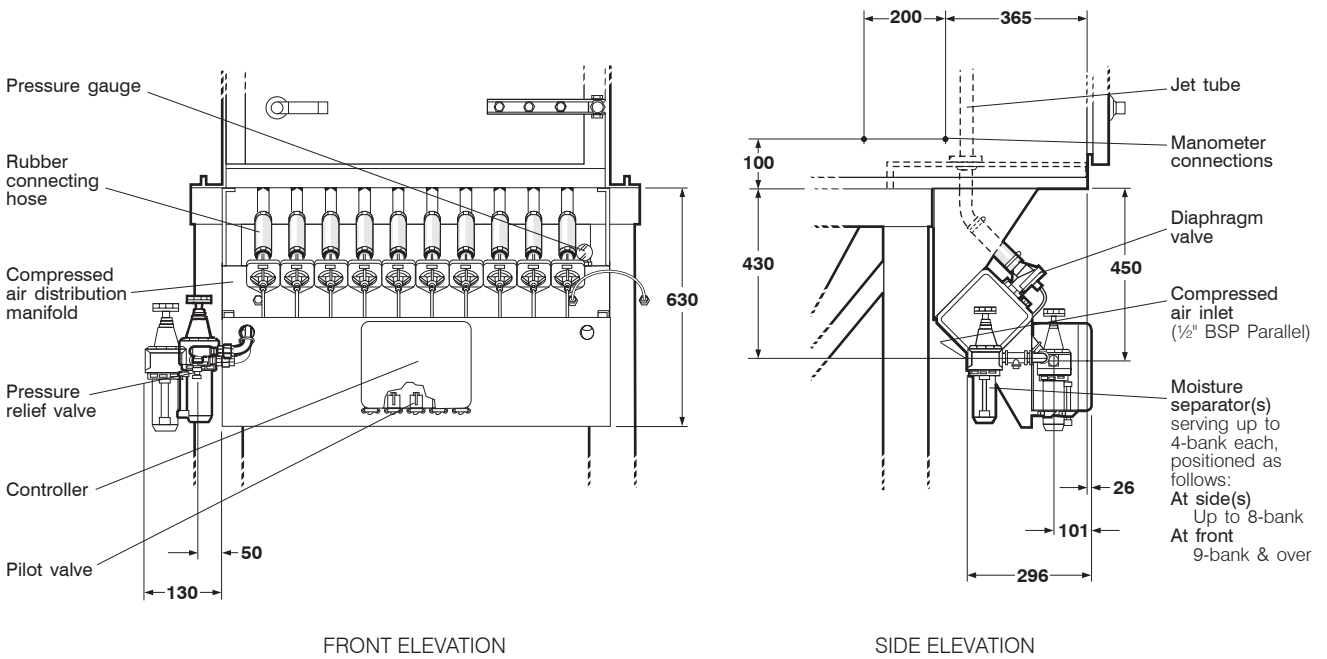

2-, 3-, 4-, 5- and 6-tier collectors (high temperature)

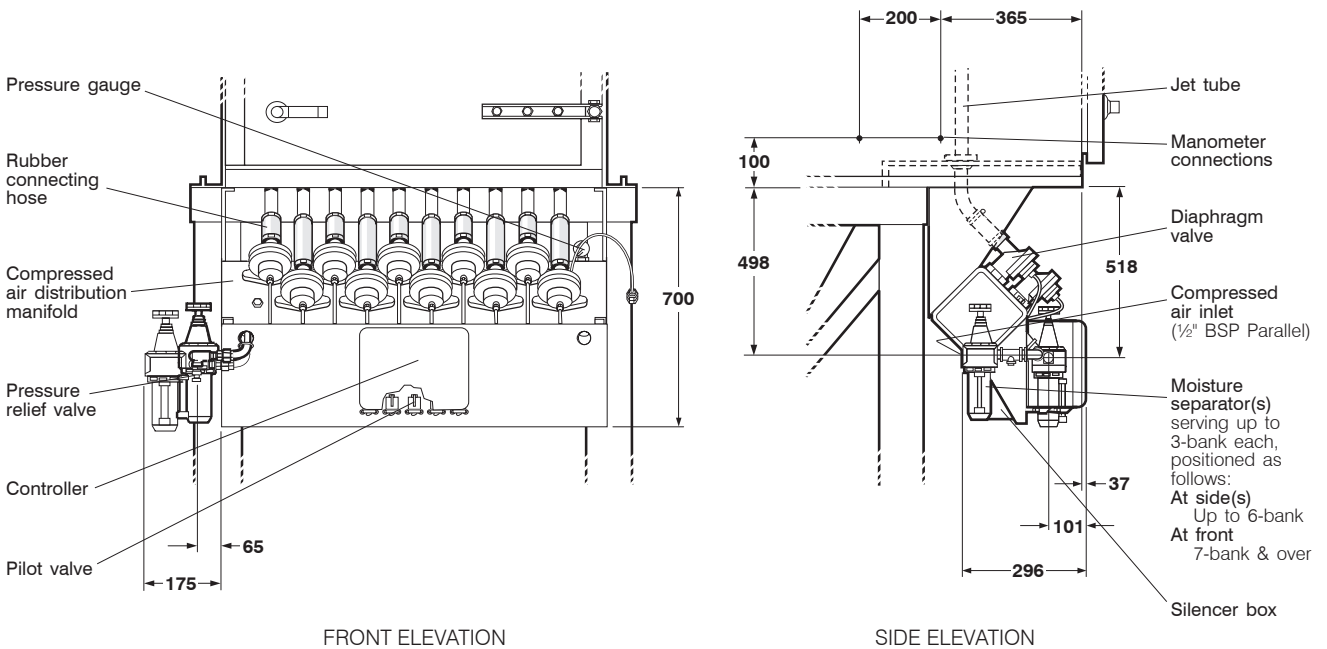

7- and 8-tier collectors

CONTROL EQUIPMENT DETAILS

Dalamatic Cased Dust Collectors – Series DLM 15

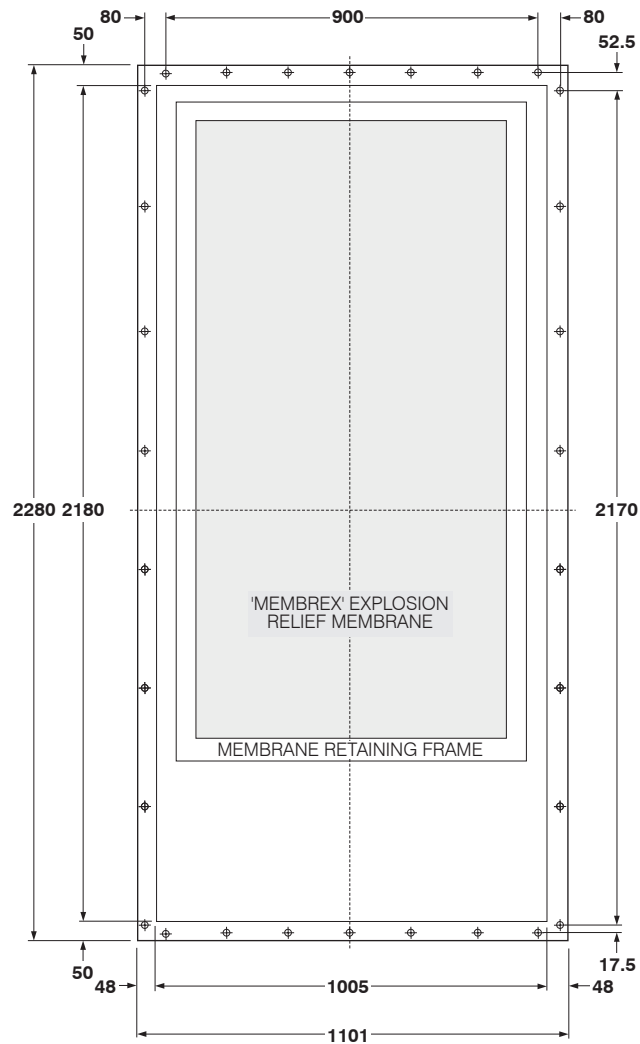

Top explosion relief flange

All holes 12 x 20 mm slots for M10 bolts. Pitch centres: 150 mm horizontally; 310 mm vertically.
 Mounting flange is flush with top of collector.

NOTE: Membrane retaining frame projects 80 mm beyond top of collector.

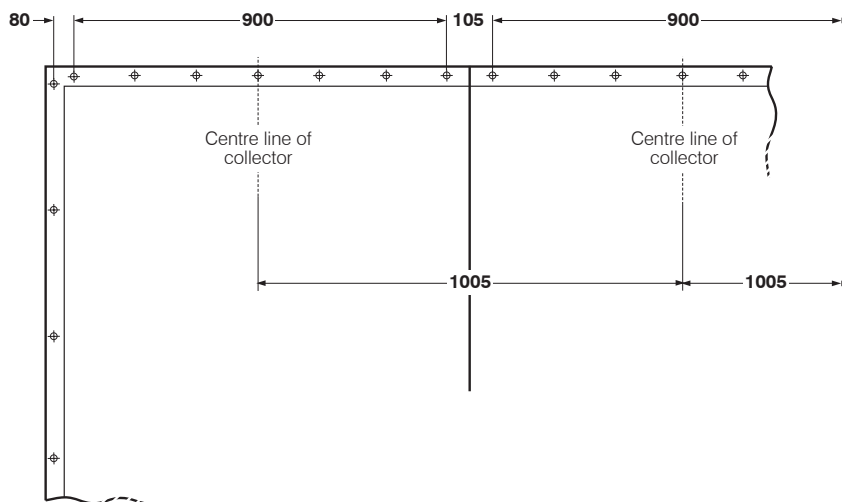

Flange extension for multi-bank collectors

EXPLOSION RELIEF FLANGE MOUNTING DETAILS

Weather protection is available for collectors fitted with top explosion relief.

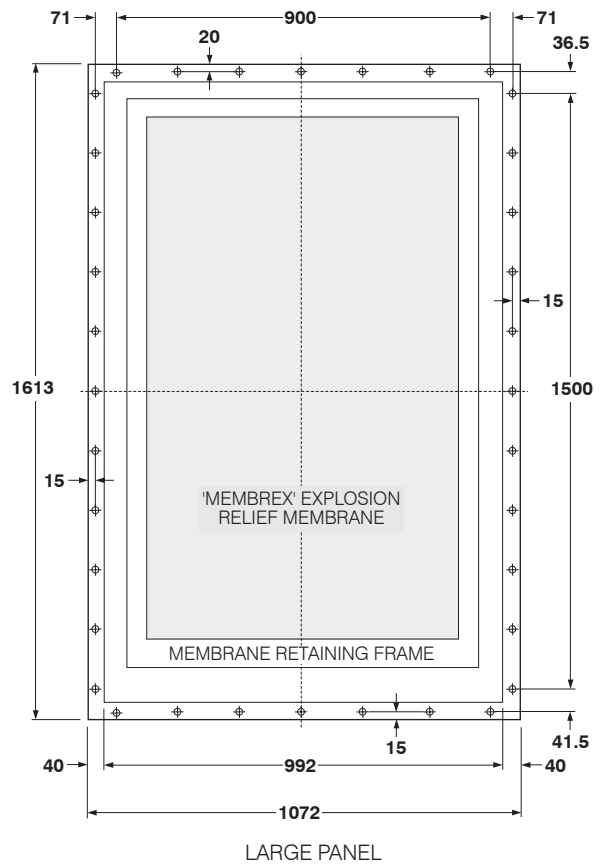
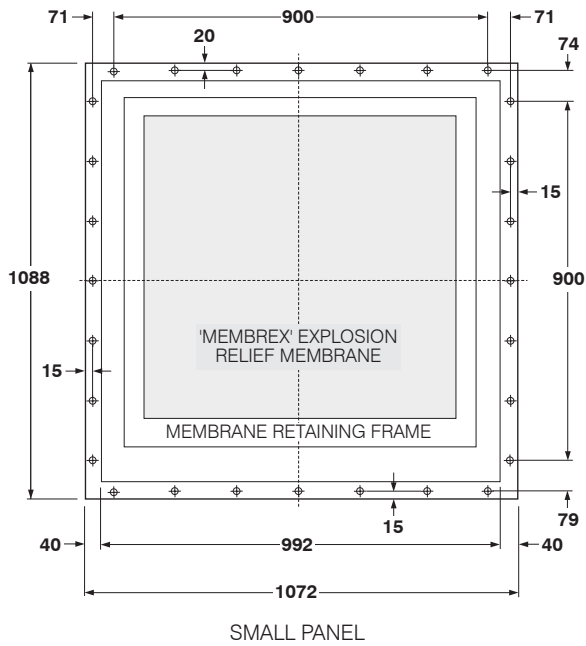

Rear explosion relief flange

Bottom and vertical bolt holes $\varnothing 10$ mm. Top bolt holes 10 x 20 mm slots. All for M8 set screws with pitch centres at 150 mm.
 NOTE: Mounting flange projects 100 mm beyond rear of collector.

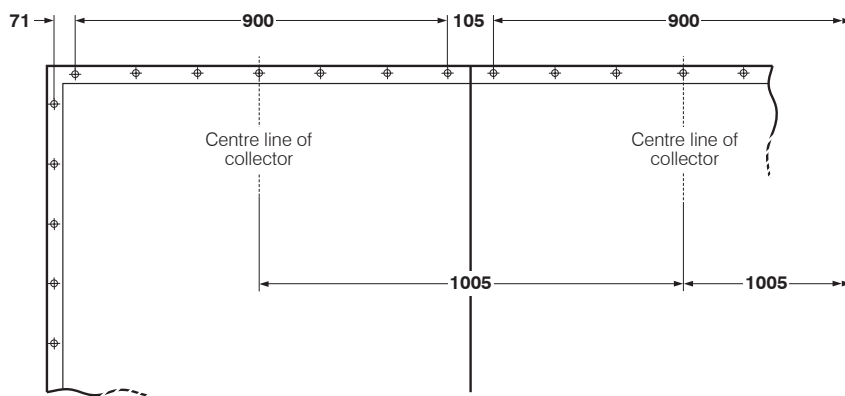

Flange extension for multi-bank collectors

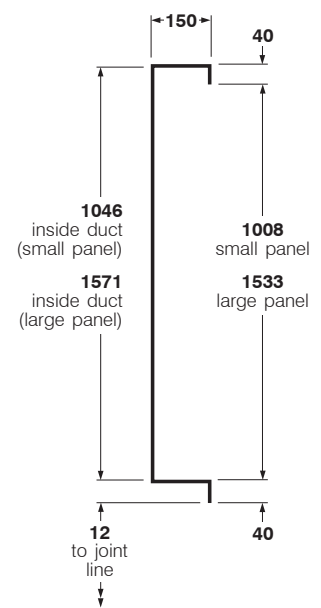

Flange section

EXPLOSION RELIEF FLANGE MOUNTING DETAILS

Dalamatic Cased Dust Collectors – Series DLM 15

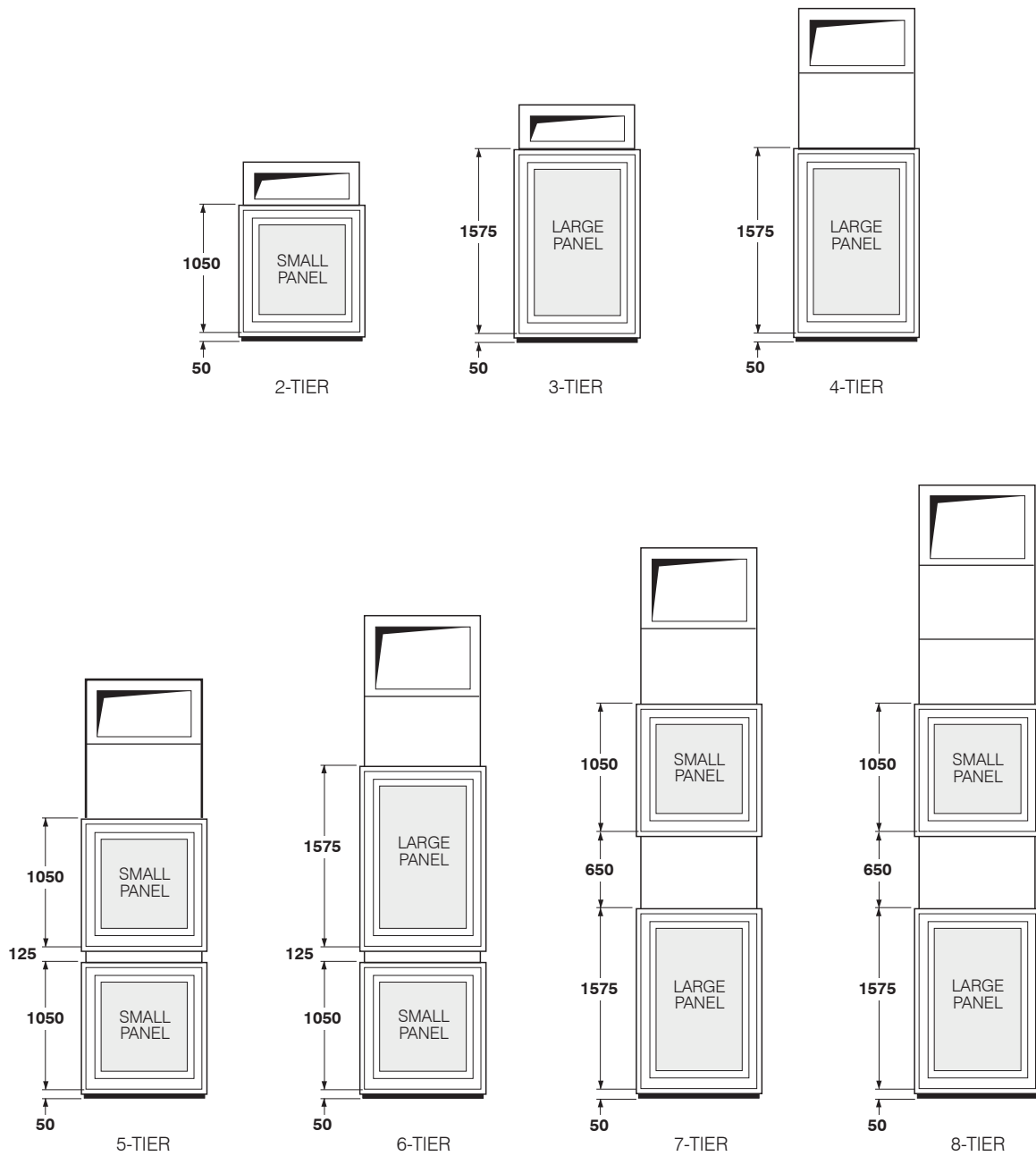

Rear explosion relief location

(1-bank collectors illustrated).

EXPLOSION RELIEF FLANGE MOUNTING DETAILS