



Donaldson.
FILTRATION SOLUTIONS

Process Filtration From Pure to Sterile

P-BE housings

MAIN FEATURES & BENEFITS:

- High quality stainless steel design
- Extremely low differential pressure
- Various connection types
- Up to 2.010 m³/h



INDUSTRIES:



- Dairy



- Pharmaceutical Industry



- Breweries



- Wineries



- Fermentation



- Biotech

Donaldson Filtration Deutschland GmbH
Büssingstr. 1
42781 Haan
Deutschland

Donaldson[®]
Ultrafilter

Web: www.donaldson.com

PRODUCT DESCRIPTION

Filter housings for the aeration, de-aeration and venting of product series P-BE are used to ensure 100% sterility in the storage of pharmaceutical products, containers of DI water, food, chemicals, and/or the deaeration of fermenters. The user-friendly two-piece housing has a splash protection to prevent liquids coming in contact with the filter medium and damage it.

Numerous sizes of housings allow to adopt the filter exactly to the respective requirements. In this product series 12 different housing sizes are available for flow rates from 4.5 to 2.010 m³/h at 1 bar (2.6 to 1.180 cfm at 14.7 psi). Due to the Donaldson modular design different filter elements can be used in this housing according to the application.

The P-BE housing is designed and developed for the following applications:

Venting applications

- Compressed Air
- Carbon Dioxide
- Nitrogen
- Ambient air

Besides the venting filter type (P)-BE and the membrane filter types (P)-PF-PP and (P)-PF-PT, sterile depth filters like the (P)-SRF or (P)-SRF N may be used with retention rates of 99.9999998 % down to virus size of 0.02 µm.

DIRECTIVES

All P-BE housings are designed in accordance with

- FDA CFR Code of Federal Regulations Title 21
- Framework regulation 1935/2004/EC

FDA



PRODUCT SPECIFICATIONS

Product Specifications

Inner Surface Finish:	<ul style="list-style-type: none">• $R_a < 1.6$
Outer Surface Finish:	<ul style="list-style-type: none">• Polished surface $R_a < 1.6$
Maximum Operating Temperature:	<ul style="list-style-type: none">• 200 °C
Connection Types:	<ul style="list-style-type: none">• Milkpipe DIN 11851 (standard at 0006–0192)• DIN or ANSI flange (standard from 0432; optional up to 0192)• Clamp (on request)
Materials:	<ul style="list-style-type: none">• Stainless Steel 1.4301 (304) (optional 1.4404; 316L)

Vent filter P-BE 0006-0192 with milkpipe connection DIN 11851

Pos.	Piece	Description
5	3	socket head screw
4	1	filter element
3	3	lone socket
2	1	lower housing bowl
1	1	upper housing bowl

Surface Finish:	inside $R_a < 1.6$ outside polished $R_a < 1.6$
Max. Operating Temperature:	+200 °C
Material Housing:	1.4301 (304)
Attaching Parts:	1.4301 (304)

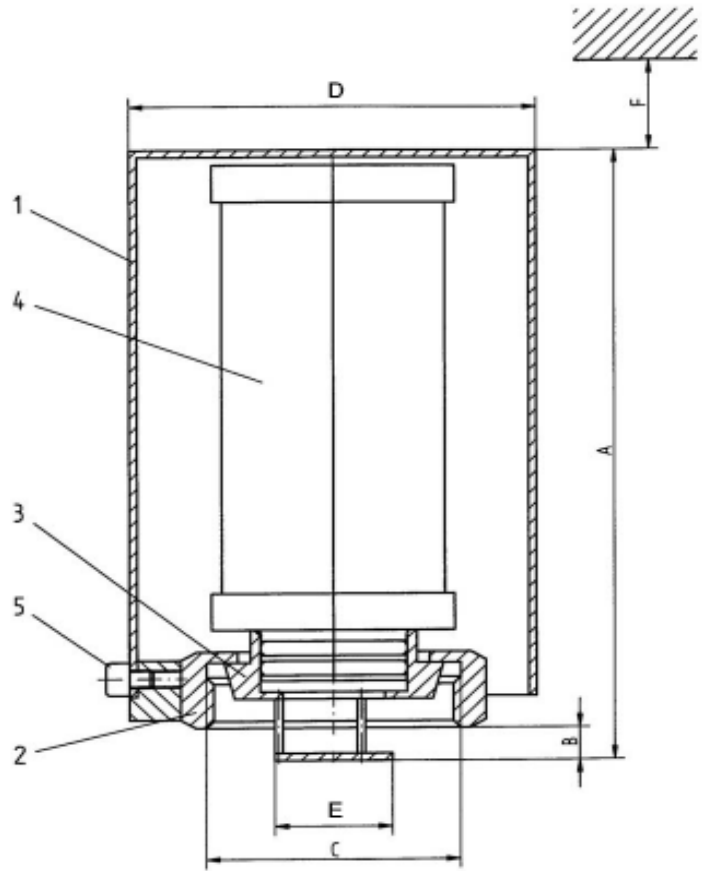

Size	Weight (kg)	A mm	B mm	C	ØD mm	E mm	F mm	Element
0006	1.5	110	9	DN 32/ Rd 58 x 1/6	85 x 2	24	100	03/10
0027	2.2	168	9	DN 40/ Rd 65 x 1/6	104 x 2	30	155	05/25
0032	2.4	186	9	DN 50/ Rd 78 x 1/6	114.3 x 2	42	155	05/30
0072	3.3	312	9	DN 50/ Rd 78 x 1/6	114.3 x 2	42	280	10/30
0144	9.2	550	9	DN 80/ Rd 110 x 1/4	154 x 2	70	580	20/30
0192	11.6	805	9	DN 80/ Rd 110 x 1/4	154 x 2	70	850	30/30

Vent filter P-BE 0432-1920 with flange connection

Pos.	Description
5	filter element
4	anchor bolt
3	lifting eye screw
2	lower housing bowl
1	upper housing bowl

Surface Finish:	inside $R_a < 1.6$ outside polished $R_a < 1.6$
Max. Operating Temperature:	+200°C
Material Housing:	1.4301 (304)
Attaching Parts:	1.4301 (304)

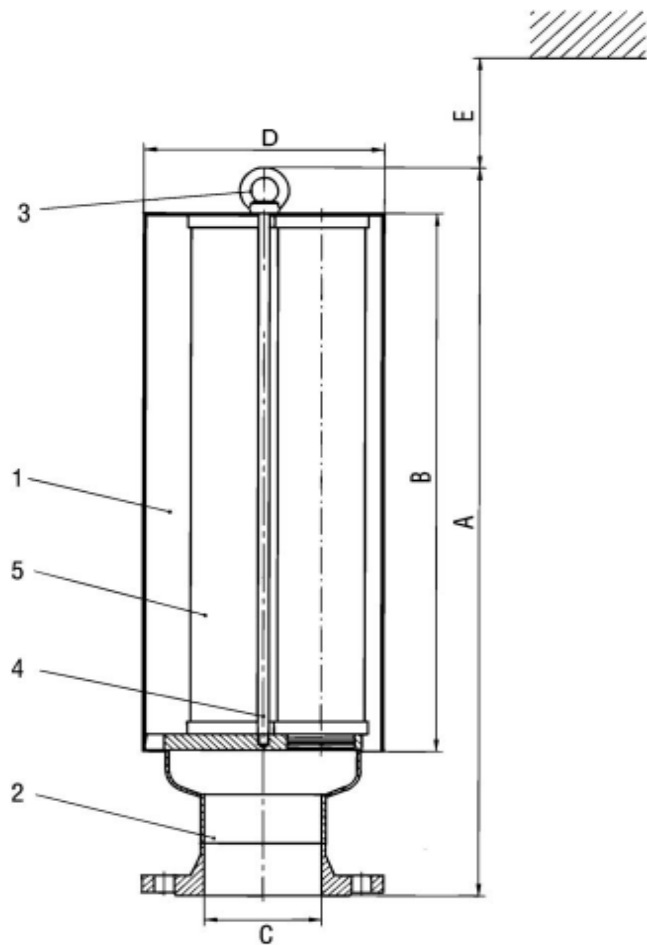

Size	Weight (kg)	A mm	B mm	C	ØD mm	E mm	Element
0432	14.5	670	530	DN 100	219.1	580	3x 20/30
0576	17.5	925	780	DN 100	219.1	850	3x 30/30
0768	30	950	780	DN 150	273.0	850	4x 30/30
1152	30	950	780	DN 150	323.9	850	6x 30/30
1536	43	960	780	DN 200	406.4	850	8x 30/30
1920	43	960	780	DN 200	406.4	850	10x 30/30

Technical alterations reserved 04/2009

- For information on integrity test equipment or integrity test services, please contact your Donaldson Sales Engineer and visit our website at www.donaldson.com!

(F119024 - Rev02 - 07/11)



Donaldson
FILTRATION SOLUTIONS