



REFRIGERATION COMPRESSED AIR DRYER BOREAS



Also  available with R-513A refrigerant

THE INTELLIGENT REFRIGERATION COMPRESSED AIR DRYER: BOREAS

Why is Compressed Air processed?

Compressed air is an essential form of driving and process energy in all fields of industrial and production manufacturing. Compressed air must be dry, free of oil and clean to avoid expensive production breakdowns.

Compressed air is generated by ambient air which is sucked into the compressor. This usually contains dirt, particles and water vapour, which condenses in the compressed air and can then lead to disruptions in operations and thereby to substantial but avoidable costs.

How does a Boreas work?

To purify the compressed air, it is led into the refrigeration compressed air dryer and is pre-cooled in an air/air heat exchanger. This pre-cooling is conducted in counter-flow with the expelled, cooled compressed air and therefore operates completely without additional energy. Further cooling to the pressure dewpoint is conducted in a refrigerant/air heat exchanger cooled by a refrigerant cycle. Throughout the cooling process, moisture turns into condensate and is automatically drained. Before being expelled, the processed compressed air is re-heated in the air/air heat exchanger by means of the entering compressed air, which lowers the relative humidity of the compressed air at the dryer outlet.

Rapid response to changing demands

This microprocessor-based controller constantly processes data such as the cooling temperature, the pressure in the refrigeration cycle, the ambient temperature and dryer-specific parameters and thereby calculates the current operating status.

Depending on the demand on the refrigeration compressed air dryer, the controller regulates the power of the compressor and the condenser via a frequency converter. At a very low demand, the refrigerant compressor is even switched off intermittently. With its function as a thermal accumulator, the heat exchanger permits a rapid response to changing demands and prevents dewpoint peaks.



DV 4300 AVS

Energy-saving load dependant control

An electronic temperature and pressure controlled expansion valve ensures constant and accurate dew-point performance. This automatically adjusts the refrigerant injection to the current temperature, pressure and flow conditions.

A frequency converter controller regulates the power consumption of both the condenser and the compressor. It is a feature of all Boreas AVS/MVS versions to control the power. With this system, the speed of one of the refrigerant compressors is continuously controlled.

With these two control concepts the energy consumption falls in proportion to the dryer load by up to 90 % at zero load. This leads to an extremely low energy consumption in the zero, partial and peak load ranges.

Power Consumption of Variable Speed versus Hot Gas Bypass*

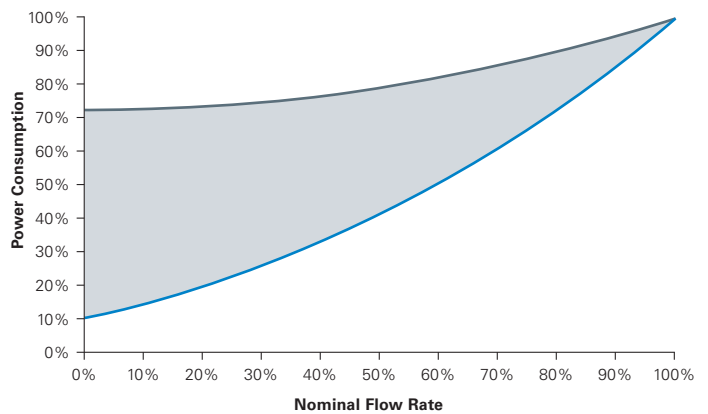

* Data based on DV 2800 AB/AVS dryers

Energy Savings
 Variable Speed Drive
 Hotgas Bypass



Features and Advantages:

- Frequency converter controller as standard
- Permanently illuminated multifunction touch display
- Constant pressure dewpoint without dewpoint peaks
- Load-dependant energy consumption, reduction by up to 90% in proportion to the rated energy consumption
- Aluminium heat exchanger
- Level-controlled zero loss condensate drain
- Optional data transfer interface for remote monitoring or to read data
- Electronic temperature and pressure controlled expansion valve

Multifunctional touch display

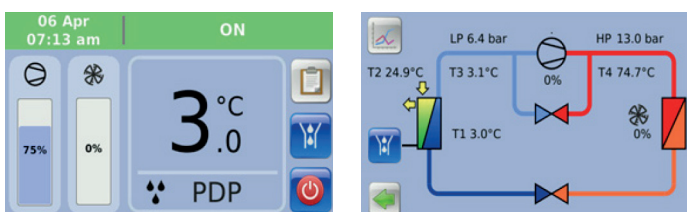

Important information at a glance

Controller Main Functions

- Display of dewpoint and power consumption
- Two alarm levels: pre-alarm and alarm
- Alarm log with operating parameters from up to one hour before the alarm
- USB port to download alarm log
- General alarm contact
- Hour meter and service reminder
- Display of inverter parameters
- RS485 interface available to communicate with other control devices (PLC, supervisor system)

THE INTELLIGENT REFRIGERATION COMPRESSED AIR DRYER: BOREAS AVS/WVS RANGE

1. Control Unit

- Energy-saving controller concept and touch display
- Inverter for variable speed control on refrigerant compressor and condenser fan
- Intelligent temperature and pressure control permanently adjusts the energy consumption to the current operating conditions and ensures constant low pressure dewpoints

2. Multifunctional Touch Display

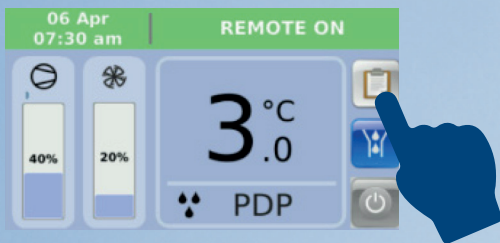

- Shows current operating parameters
- Additional functions such as data loggers, service messages, alarm messages, alarm history and operating hours counter
- Energy-saving data is constantly calculated

3. Refrigerant Scroll Compressor

- Provides reliable compression of refrigerant with low vibrations
- Low noise emission

4. Electronical Temperature and Pressure Controlled Expansion Valve

- Ensures constant and accurate dewpoint performance
- Automatically adapts the refrigerant injection to the current temperature, pressure and flow conditions

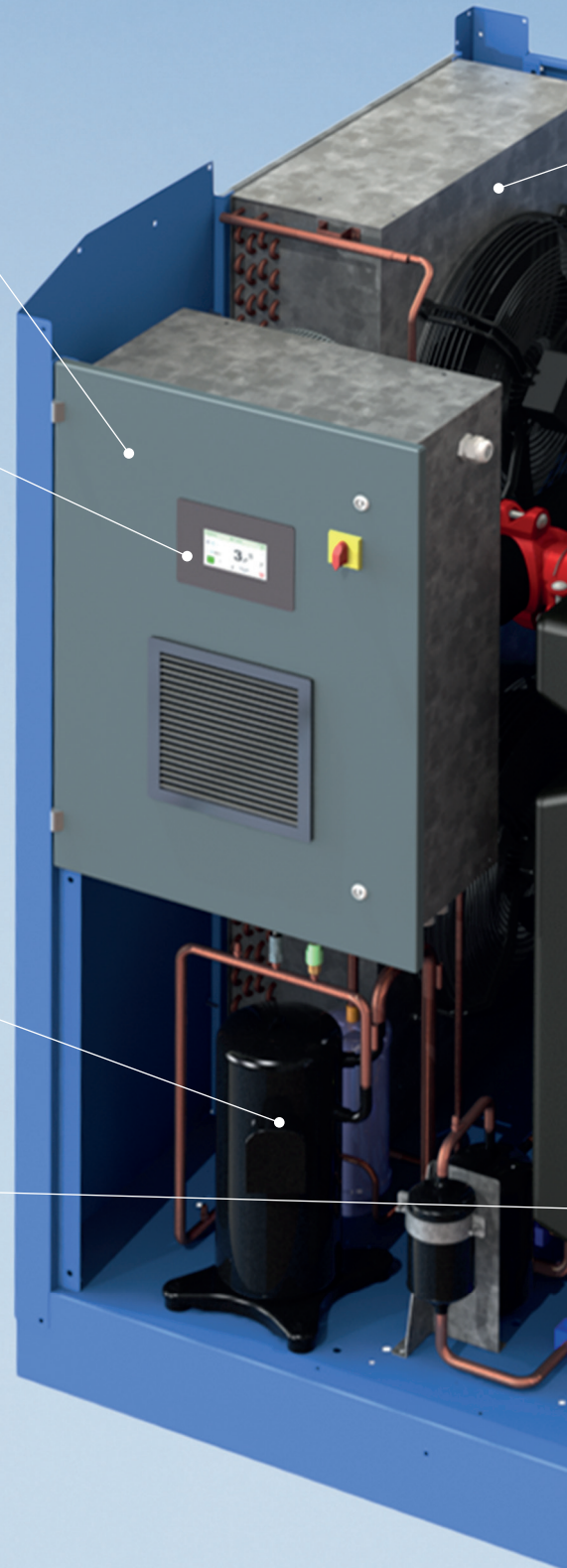

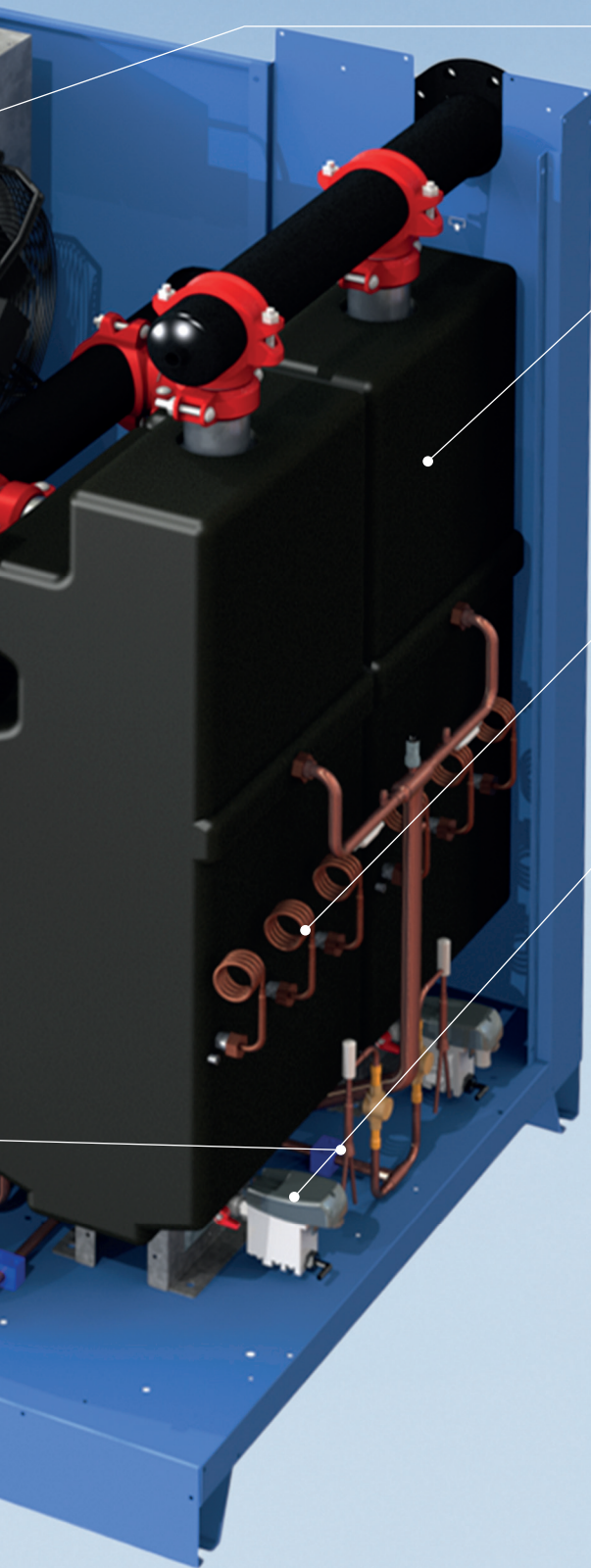

5. High-performance Condensers

- Boreas series is available with both air cooled or water cooled condensers

6. High-performance Aluminium Heat Exchanger

- Generously proportioned high-performance air/air and refrigerant/air heat-exchangers
- Integrated condensate separation system ensure compact and space-saving design
- Low differential pressure and insensitive to dirt due to generously proportioned flow ducts

7. Also available with R-513A refrigerant



- Low global warming potential (GWP)
- No ozone depleting potential (ODP)
- A1 group L1 safety classification- low toxicity, not flammable

8. Electronical, Zero-Air-Loss Condensate Drain

- All Boreas refrigeration air dryers are equipped with electronical, level-controlled condensate drains on each air to air heat exchanger module.
- No air-loss during condensate drain process



How can we meet your filtration needs? Please contact us on CAP-europe@donaldson.com

TECHNICAL DATA

Product Specifications

Type	Volume flow m ³ /h	Volume flow m ³ /min.	Differential pressure mbar	Cooling air requirement* m ³ /h	Cooling water requirement** m ³ /h	Power consumption kW*/kW**	Power supply
DV 1260	1260	21	210	5400	0.76	2.20 / 2.00	400V±10%/3/50Hz
DV 1650	1650	28	160	7200	0.98	3.10 / 2.30	400V±10%/3/50Hz
DV 1800	1800	30	170	7400	0.99	3.50 / 2.80	400V±10%/3/50Hz
DV 2000	2000	33	210	7400	1.11	3.90 / 3.20	400V±10%/3/50Hz
DV 2300	2300	38	190	14400	1.23	3.80 / 3.40	400V±10%/3/50Hz
DV 2800	2800	47	120	14400	1.27	4.40 / 3.90	400V±10%/3/50Hz
DV 3500	3500	58	190	14800	2.03	6.10 / 5.10	400V±10%/3/50Hz
DV 4300	4300	72	250	14800	2.54	7.50 / 6.30	400V±10%/3/50Hz
DV 5500	5500	92	210	21600	2.87	9.00 / 7.40	400V±10%/3/50Hz
DV 6250	6250	104	230	22200	3.26	10.60 / 8.50	400V±10%/3/50Hz
DV 7000	7000	117	190	28800	3.79	10.80 / 9.10	400V±10%/3/50Hz
DV 8750	8750	146	260	29600	4.34	14.10 / 11.30	400V±10%/3/50Hz
DV 10500	10500	175	210	44400	5.58	16.90 / 12.20	400V±10%/3/50Hz
DV 12500	12500	208	230	44400	7.90	21.60 / 18.20	400V±10%/3/50Hz
DV 14000	14000	233	190	56000	9.20	27.60 / 22.40	400V±10%/3/50Hz
DV 17500	17500	292	260	56000	10.70	30.50 / 29.90	400V±10%/3/50Hz
DV 21000	21000	350	210	88800	11.16	33.80 / 24.40	400V±10%/3/50Hz

* only air cooled versions ** only water cooled versions at 30°C cooling temperature

All dryers also available with a 460V±10%/3/60Hz power supply.

Sizing

Operating pressure (bar g) max. 14 bar g	2	3	4	5	6	7	8	9	10	12	14
Correction factor f_p	0.49	0.66	0.77	0.86	0.93	1.00	1.05	1.10	1.14	1.21	1.27

Compressed air inlet temperature (°C) Operating temperature max. 70°C	≤ 25	30	35	40	45	50	55	60	65	70
Correction factor f_{ti}	1.20	1.12	1.00	0.83	0.69	0.59	0.50	0.44	0.39	0.37

Temperature of ambient air (°C) Ambient temperature +1°C to +50°C	≤ 25	30	35	40	45	50
Correction Factor f_{tc}	1.00	0.96	0.90	0.82	0.72	0.60

No correction factor needed for cooling water from 15- 35°C.

Pressure dewpoint (°C)	3	5	7	10
Correction factor f_{td}	1.00	1.09	1.19	1.37

Dimensions

Type	Width (W)	Height (H)	Depth (D)
DV 1260 AVS/WVS	848	1590	1000
DV 1650 AVS/WVS	848	1590	1000
DV 1800 AVS/WVS	848	1590	1000
DV 2000 AVS/WVS	848	1590	1000
DV 2300 AVS/WVS	1135	1750	1265
DV 2800 AVS/WVS	1135	1750	1265
DV 3500 AVS/WVS	1135	1750	1265
DV 4300 AVS/WVS	1135	1750	1265
DV 5500 AVS/WVS	1300	1810	1810
DV 6250 AVS/WVS	1300	1810	1810
DV 7000 AVS/WVS	1400	1870	2260
DV 8750 AVS/WVS	1400	1870	2260
DV 10500 AVS/WVS	1547	AVS: 2439 WVS: 2168	2244
DV 12500 AVS*/WVS	AVS: 3600 WVS: 1450	AVS: 1810 WVS: 2170	AVS: 2427 WVS: 2845
DV 14000 AVS*/WVS	AVS: 3800 WVS: 1450	AVS: 1870 WVS: 2170	AVS: 2955 WVS: 2845
DV 17500 AVS*/WVS	AVS: 3800 WVS: 1450	AVS: 1870 WVS: 2150	AVS: 2955 WVS: 3295
DV 21000 AVS*/WVS*	4458	AVS: 2439 WVS: 2168	2985

* Twin unit – two dryers in parallel. Scope of supply: two dryers, two connection pipes for compressed air inlet and outlet as well as support brackets.

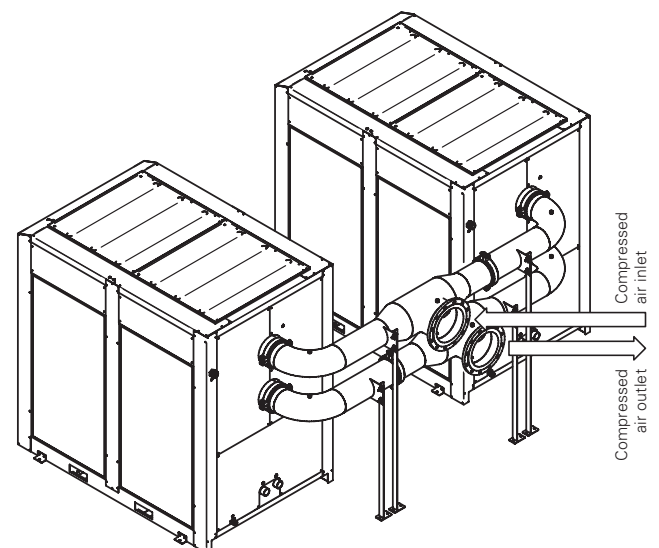
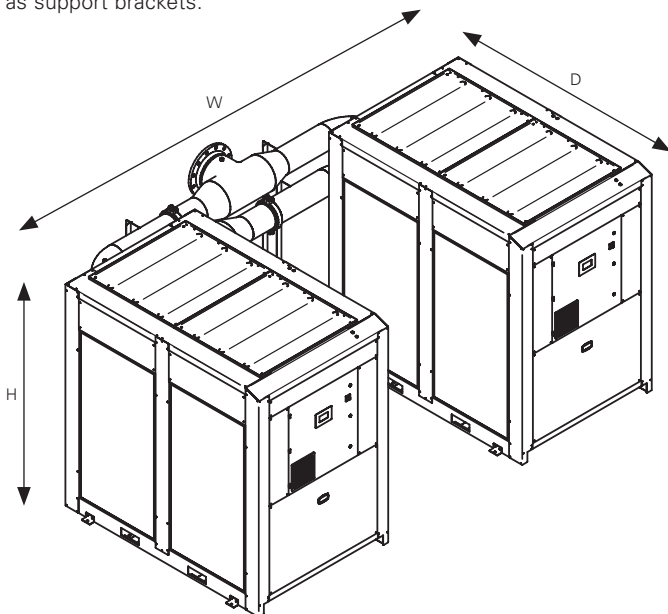
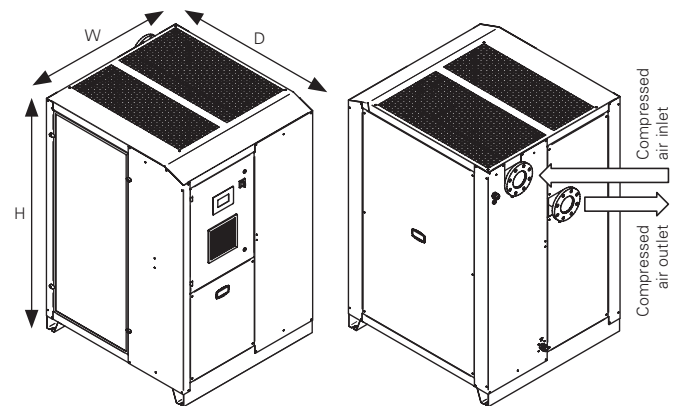
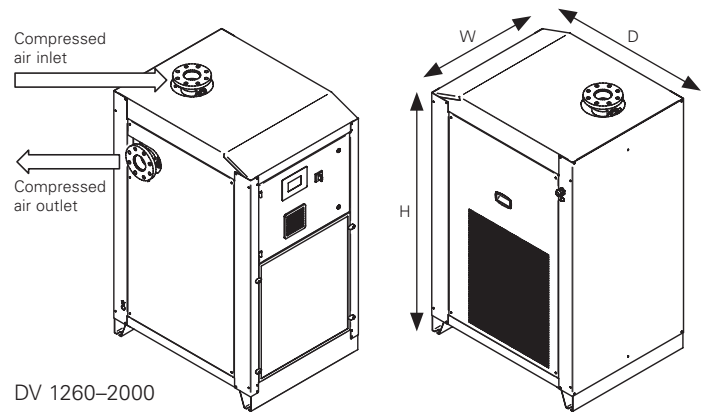

Twin Units

Sizing example

$\dot{V}_{nom} = 1,800 \text{ m}^3/\text{h}$ (intake volume flow of the compressor), compressed air inlet temperature = 40°C , cooling water temperature = 35°C , operating pressure = 9 bar, pressure dewpoint = $+3^\circ\text{C}$

$$\dot{V}_{korr} = \frac{\dot{V}_{nom}}{f} = \frac{1,800 \text{ m}^3/\text{h}}{1.06 \times 0.83 \times 0.90 \times 1.00} = 2,273 \text{ m}^3/\text{h}$$

Calculated dryer size: DV 2300

TECHNICAL DATA

Product Specifications R513A versions

Type	Volume flow m ³ /h	Volume flow m ³ /min.	Differential pressure mbar	Cooling air requirement* m ³ /h	Cooling water requirement** m ³ /h	Power consumption kW*/kW**	Power supply
DV 1260 AVS/ WVS R513A	1260	21	210	5400	0.76	2.00 / 1.70	400V±10%/3/50-60Hz
DV 1650 AVS/ WVS R513A	1650	28	160	7200	0.98	3.10 / 2.60	400V±10%/3/50-60Hz
DV 1800 AVS/ WVS R513A	1800	30	170	7400	0.99	3.90 / 3.40	400V±10%/3/50-60Hz
DV 2000 AVS/ WVS R513A	2000	33	210	7400	1.11	3.90 / 3.40	400V±10%/3/50-60Hz
DV 2300 AVS/ WVS R513A	2300	38	190	10800	1.23	4.30 / 3.80	400V±10%/3/50-60Hz
DV 2800 AVS/ WVS R513A	2800	47	120	14400	1.27	5.00 / 4.00	400V±10%/3/50-60Hz
DV 3500 AVS/ WVS R513A	3500	58	190	14400	2.03	6.00 / 5.20	400V±10%/3/50-60Hz
DV 4300 AVS/ WVS R513A	4300	72	250	14800	2.54	8.20 / 7.20	400V±10%/3/50-60Hz
DV 5500 AVS/ WVS R513A	5500	92	210	21600	2.87	8.60 / 7.50	400V±10%/3/50-60Hz
DV 6250 AVS/ WVS R513A	6250	104	230	22200	3.26	9.70 / 8.30	400V±10%/3/50Hz
DV 7000 AVS/ WVS R513A	7000	117	190	28800	3.79	11.00 / 9.40	400V±10%/3/50Hz
DV 8750 AVS/ WVS R513A	8750	146	260	29600	4.34	14.20 / 12.50	400V±10%/3/50Hz

* only air cooled versions ** only water cooled versions at 30°C cooling temperature

All dryers also available with a 460V±10%/3/60Hz power supply.

See previous pages for sizing and dimensions.

Donaldson[®]
Ultrafilter

Compressed Air Filtration · Filters for Sterile Air, Steam and Liquids ·
Refrigerant Drying · Adsorption Drying · Condensate Drains ·
Condensate Purification Systems · Process Air and Gas Processing



Donaldson[®]
FILTRATION SOLUTIONS

Total Filtration Management

Donaldson offers a wide variety of solutions to reduce your energy costs, improve your productivity, guarantee production quality and help protect the environment.

Total Filtration Service

A comprehensive range of services keeps your production at peak performance and at the lowest total cost of ownership.

Please contact us:

Donaldson Europe B.V.

Research Park Building No. 1303 · Interleuvenlaan 1

B-3001 Leuven · Belgium

Phone +32(0)16 38 38 11 · Fax +32(0)16 40 00 77

CAP-europe@donaldson.com · www.donaldson.com