

Aftercooler for compressed air and gases UFK-L

The aftercooler UFK-L is designed to cool compressed air, but can be used for other gases as well.

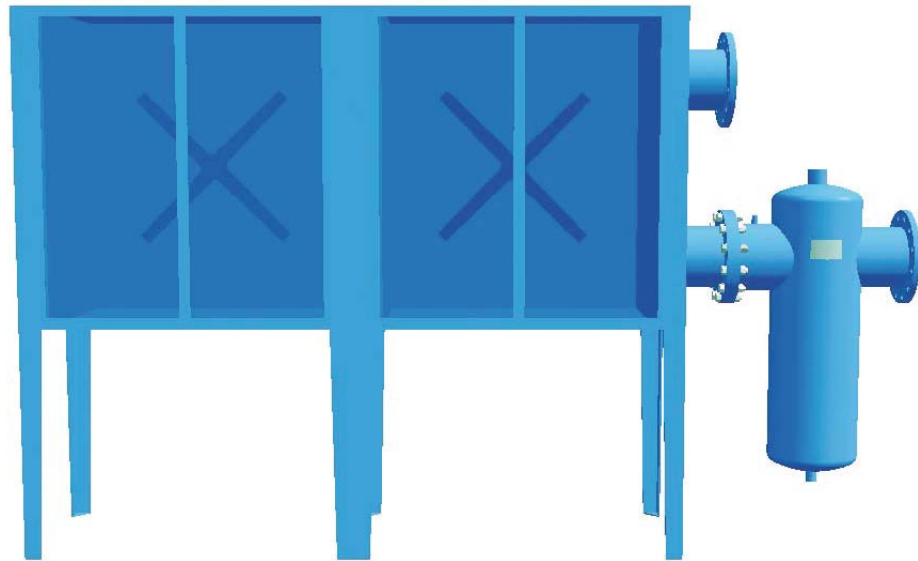

Product description:

The UFK-L as an additional piece of equipment after the compressor supports an efficient and economical purification of compressed air.

The warm incoming air is lead over the cooling pipes where the cooling air is adsorbing the heat. The generated condensate will be drained by a cyclone separator.

In this product series, 12 different housings are available ranging from a volume flow of 65 to 5000 m³/h.

Features:

The air cooled aftercooler consists of the cooling device in a steel plate cabinet, the fan with integrated electric motor and a cyclone separator.

Technical Data

Materials:	
Housing	carbon steel
Surface finish	Polyester resin coating resp. cathodic dip-coating

Maximum operating pressure:	
0065 - 0300	16 bar
0450-5000	12 bar

Maximum operating temperature:	
120°C	

Maximum ambient temperature:	
45°C	

Connection:	
1"-2½" BSP DN 80-DN 150 (see technical drawings)	

Electr. connection:	
Motor	
0065-0125	230 V/1/50 Hz
0175-5000	400 V/3/50 Hz

Annotation:	
The flow capacity is related to a compressed air volume flow (at 1bar, 20°C) at 7 bar pressure, an air cooler inlet temperature of 120°C and an air cooler outlet temperature which is 10°C higher than the ambient temperature.	

Aftercooler UFK-L 0065-5000

Operating parameters:	
Max. operating pressure:	
0065-0300:	16 bar
0450-5000:	12 bar
Test pressure:	
0065-0300:	24 bar
0450-5000:	18 bar
Max. operating temperature: 120°C	
For operating conditions not according to standard see tables with correction factors	

Type 0065 - 1000

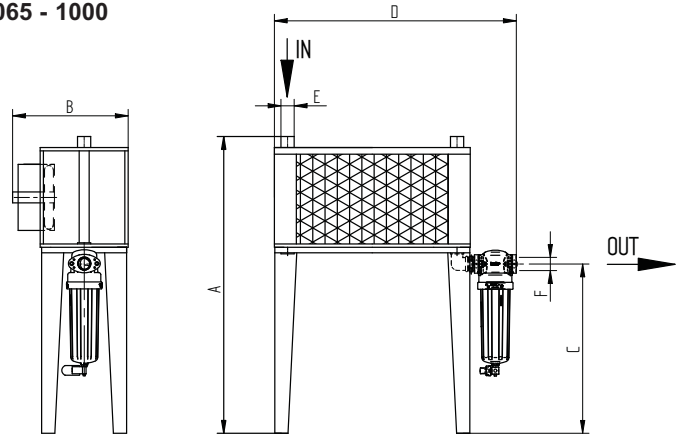

Correction factors:

Ambient temperature						
°C	20	25	30	35	40	45
CF	1.04	1	0.94	0.87	0.77	0.65

Air inlet temperature							
°C	60	70	80	90	100	110	120
CF	1.59	1.44	1.32	1.21	1.12	1.05	1

ΔT = Air inlet temperature - Air outlet temperature					
°C	3	6	9	12	15
CF	0.45	0.72	1	1.28	1.55

Operating pressure								
bar	5	6	7	8	9	10	11	12
CF	0.86	0.93	1	1.06	1.11	1.15	1.19	1.22

Type 1350 - 5000

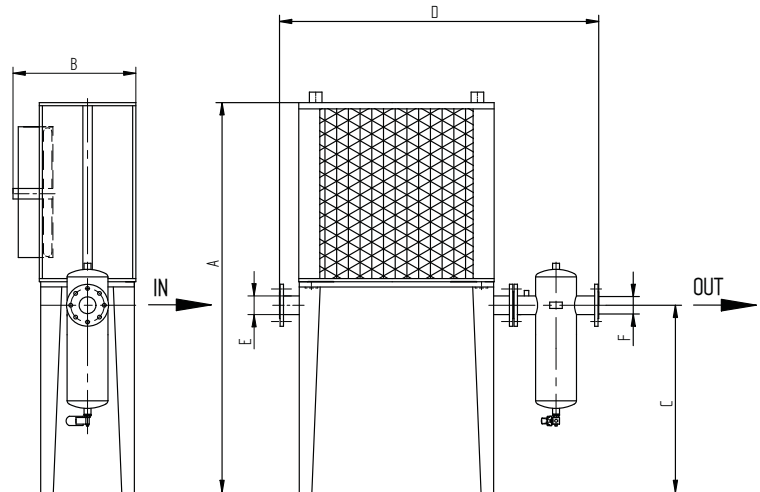

Size	Max. air flow rate		Fan cooling airflow m ³ /h	Power cons. Watt	Power supply V/Ph/Hz	Weight kg	Dimensions						Cyclone separator
	m ³ /h	l/min.					A mm	B mm	C mm	D mm	Ø E	Ø F	
0065	60	1.000	20	800	230/1/50	20	955	270	555	585	G 1	G ½	DF-C 0120
0125	120	2.000	20	800	230/1/50	22	955	270	555	620	G 1	G ¾	DF-C 0210
0175	180	3.000	115	2980	400/3/50	31	1145	270	585	840	G 1½	G ¾	DF-C 0210
0300	240	4.000	135	3790	400/3/50	34	1145	330	675	1050	G 1½	G 1	DF-C 0320
0450	390	6.500	690	6500	400/3/50	51	1145	360	675	1055	G 2	G 1½	DF-C 0450
0750	720	12.000	760	8200	400/3/50	97	1625	655	675	1055	G 2	G 2	DF-C 0750
1000	960	16.000	760	8200	400/3/50	120	1625	655	675	1055	G 2½	G 2	DF-C 1100
1350	1200	20.000	660	12000	400/3/50	240	2120	490	765	1390	G 3	G 3	SG-Z 1950
1950	1800	30.000	660	12000	400/3/50	280	2060	490	945	1970	DN 100	DN 100	SG-Z 1950
2500	2400	40.000	2x760	2x8200	400/3/50	300	2060	490	945	2290	DN 100	DN 100	SG-Z 1950
3500	3000	50.000	2x470	2x8400	400/3/50	310	2000	620	1020	3245	DN 125	DN 125	SG-Z 2750
5000	4500	75.000	2x470	2x8400	400/3/50	390	2100	770	980	3370	DN 150	DN 150	SG-Z 5000